



HardCabs →

Mahindra Roxor

Complete Kit
(989020)



18865 Goll St. San Antonio, TX 78266
Phone: 800-862-6658
Sales: sales@vintageair.com
Tech Support: tech@vintageair.com
www.vintageair.com



www.vintageair.com

Table of Contents

Cover.....	1
Table of Contents.....	2
Packing List/Parts Disclaimer.....	3
Information Page.....	4
Wiring Notice.....	5
Passenger Compartment Disassembly.....	6
Passenger Compartment Disassembly (Cont.), Engine Compartment Disassembly.....	7
Engine Compartment Disassembly (Cont.).....	8
Engine Compartment Disassembly (Final), Heater Hose Modification.....	9
Heater Hose Modification (Cont.), Compressor Installation, Condenser Installation.....	10
Engine Compartment Modification.....	11
Engine Compartment Preparation.....	12
Cowl Modification.....	13
Cowl Modification (Cont.), Evaporator Preparation.....	14
Evaporator Preparation (Cont.), Defrost Louver Installation.....	15
Evaporator Installation.....	16
Drain Hose Installation, Heater Hose & Heater Control Valve Installation.....	17
Heater Hose & Heater Control Valve Installation (Cont.).....	18-19
Heater Hose & Heater Control Valve Installation (Final), Lubricating O-rings, Properly Seated O-ring Land.....	20
Fan Shroud Assembly & Installation.....	21-22
A/C Hose Installation.....	23-24
A/C Hose Installation (Final), Wiring Installation (Roxpower Equipped).....	25
Wiring Installation (Without Roxpower).....	26
Wiring Installation (Without Roxpower)(Cont.), Safety Switch Wiring.....	27
Safety Switch Wiring (Cont.).....	28
Defrost Duct and Hose Installation, Dash Reassembly.....	29
Dash Reassembly (Cont.).....	30
Final Steps: Completing the Install.....	31
Quality Crimp Guideline.....	32
Mahindra Wiring Diagram.....	33
Operation of Controls.....	34
Driver Side Dash Bracket Template.....	35
Packing List.....	36

Important Note for 2018 M/T Models:

- **Due to firewall differences, some additional steps and modifications may be required - See Pages 11, 16, 17 and 35 for more information.**



www.vintageair.com

Packing List: Complete Kit (989020)

No.	Qty.	Part No.	Description
1.	1	746014	Mahindra Roxor Slimline Subcase
2.	1	037031	Condenser, 16" x 18", Super Flow
3.	1	046702	Compressor, 6.1 CID 134A V-Groove
4.	1	159020	Bracket Kit, Compressor
5.	1	549020	Hose Kit, Reduced Barrier Standard
6.	1	039020	Condenser Kit
7.	1	631020	Installation Kit
8.	1	280490	Fan Shroud Assembly
9.	5'	06250-VUE	Duct Hose, 2 1/2"

**** Before beginning installation, open all packages and check contents of shipment. Please report any shortages directly to Vintage Air within 15 days. After 15 days, Vintage Air will not be responsible for missing or damaged items.**

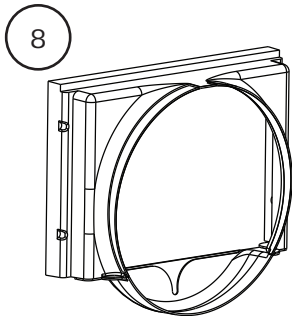
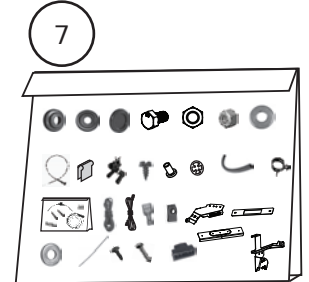
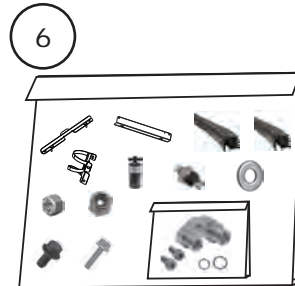
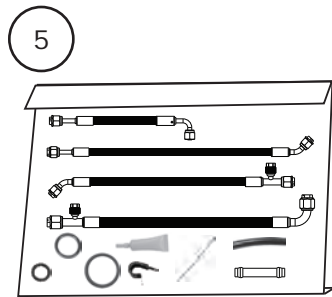
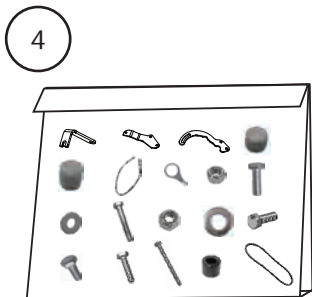
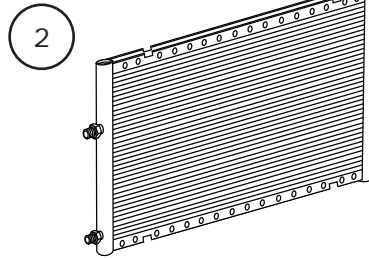
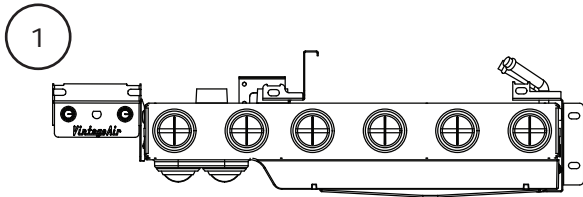

NOTE: Images may not depict actual parts and quantities. Refer to packing list for actual parts and quantities.



www.vintageair.com

Important Notice—Please Read

For Maximum System Performance, Vintage Air Recommends the Following:

NOTE: Vintage Air systems are designed to operate with R134a refrigerant only. Use of any other refrigerant could damage your A/C system and/or vehicle, and possibly cause a fire, in addition to potentially voiding the warranties of the A/C system and its components.

Refrigerant Capacities:

Vintage Air System: 1.7 lbs. (27.2 oz.) or 771 grams of **R134a**, charged by weight with a quality charging station or scale. **NOTE: Use of the proper type and amount of refrigerant is critical to system operation and performance.**

Other Systems: Consult manufacturer's guidelines.

Lubricant Capacities:

New Vintage Air-Supplied Sanden Compressor: No additional oil needed (Compressor is shipped with proper oil charge).

All Other Compressors: Consult manufacturer (Some compressors are shipped dry and will need oil added).

Safety Switches

Your Vintage Air system is equipped with a binary pressure safety switch. A binary switch disengages the compressor clutch in cases of extreme low pressure conditions (refrigerant loss) or excessively high head pressure (406 PSI) to prevent compressor damage or hose rupture. A trinary switch combines Hi/Lo pressure protection with an electric fan operation signal at 254 PSI, and should be substituted for use with electric fans. Compressor safety switches are extremely important since an A/C system relies on refrigerant to circulate lubricant.

Service Info:

Protect Your Investment: Prior to assembly, it is critical that the compressor, evaporator, A/C hoses and fittings, hardlines, condenser and receiver/drier remain capped. Removing caps prior to assembly will allow moisture, insects and debris into the components, possibly leading to reduced performance and/or premature failure of your A/C system. This is especially important with the receiver/drier.

Additionally, when caps are removed for assembly, **BE CAREFUL!** Some components are shipped under pressure with dry nitrogen.

Evacuate the System for 35-45 Minutes: Ensure that system components (Drier, compressor, evaporator and condenser) are at a temperature of at least 85°F. On a cool day, the components can be heated with a heat gun **or** by running the engine with the heater on before evacuating. Leak check and charge to specifications.

Bolts Passing Through Cowl and/or Firewall:

To ensure a watertight seal between the passenger compartment and the vehicle exterior, for all bolts passing through the cowl and/or firewall, Vintage Air recommends coating the threads with silicone prior to installation.

Heater Hose (not included with this kit):

Heater hose may be purchased from Vintage Air (Part#31800-VUD) or your local parts retailer. Routing and required length will vary based on installer preference.



www.vintageair.com

Important Wiring Notice—Please Read

Some vehicles may have had some or all of their radio interference capacitors removed. There should be a capacitor found at each of the following locations:

- 1. On the positive terminal of the ignition coil.**
- 2. If there is a generator, on the armature terminal of the generator.**
- 3. If there is a generator, on the battery terminal of the voltage regulator.**

Most alternators have a capacitor installed internally to eliminate what is called “whining” as the engine is revved. If whining is heard in the radio, or just to be extra cautious, a radio interference capacitor can be added to the battery terminal of the alternator.

It is also important that the battery lead is in good shape and that the ground leads are not compromised. There should be a heavy ground from the battery to the engine block, and additional grounds to the body and chassis.

If these precautions are not observed, it is possible for voltage spikes to be present on the battery leads. These spikes come from ignition systems and charging systems, and from switching some of the vehicle’s other systems on and off. Modern computer-operated equipment can be sensitive to voltage spikes on the power leads, which can cause unexpected resets, strange behavior and/or permanent damage.

Vintage Air strives to harden our products against these types of electrical noise, but there is a point where a vehicle’s electrical system can be degraded so much that nothing can help.

Radio interference capacitors should be available at most auto and truck parts suppliers. They typically are cylindrical in shape, a little over an inch long and a little over a half-inch in diameter, and they have a single lead coming from one end of the cylinder with a terminal on the end of the wire, as well as a mounting clip which is screwed into a good ground on the vehicle. The specific value of the capacitance is not too significant in comparison to ignition capacitors that are matched with the coil to reduce pitting of the points.

- Care must be taken, when installing the compressor lead, not to short it to ground. The compressor lead must not be connected to a condenser fan or to any other auxiliary device. Shorting to ground or connecting to a condenser fan or any other auxiliary device may damage wiring or the compressor relay, and/or cause a malfunction.
- When installing ground leads on Gen 5 systems, the blower control ground and ECU ground must be connected directly to the negative battery post.
- For proper system operation, the heater control valve must be connected to the ECU.



www.vintageair.com

Passenger Compartment Disassembly

NOTE: Before starting the installation, check the function of the vehicle (horn, lights, etc.) for proper operation, study the instructions, illustrations, photos & diagrams. Begin by removing any accessories mounted or wired to the dash. A base model Mahindra Roxor was used for example.

Perform the following:

1. Behind the dash, unplug the ignition, gauge cluster, headlight switch and horn button (See Photo 1, below).
NOTE: Heater equipped vehicles may have a control switch as well.
2. Disconnect any accessory switches (See Photo 2, below).
3. Disconnect 12v power plug. (See Photo 3, below).
4. Remove the (2) bolts from the passenger-side dash to unbolt the hood release (See Photo 4, below).
5. Carefully remove the plastic steering column cover with a plastic trim tool (See Photo 5, below). **NOTE: It is secured with double stick adhesive tape.**
6. Remove (3) 12mm bolts from around the steering column (See Photo 6, below).

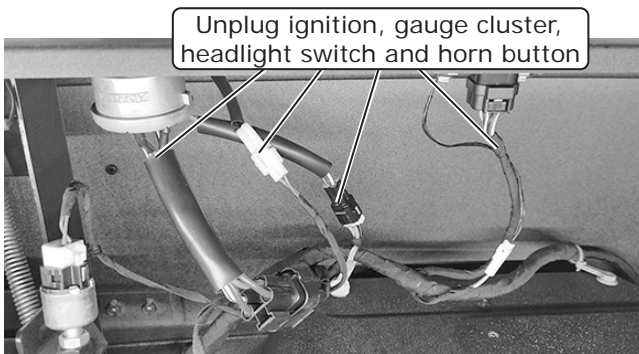

Photo 1

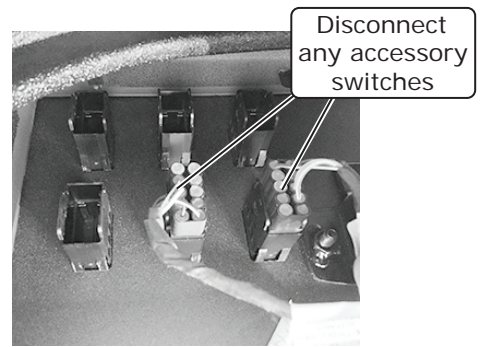

Photo 2

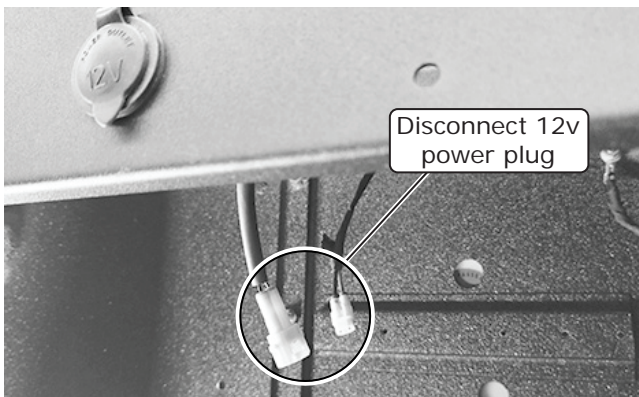

Photo 3



Photo 4

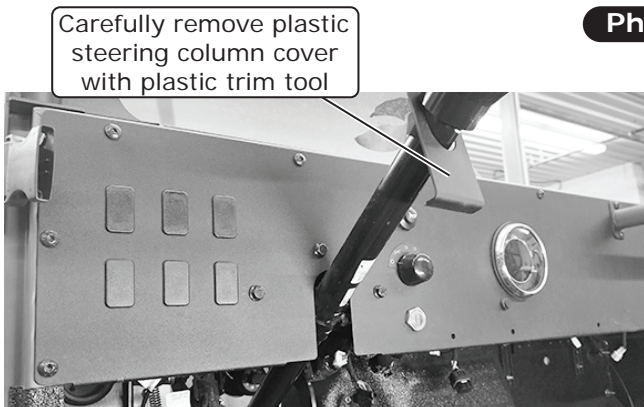

Photo 5

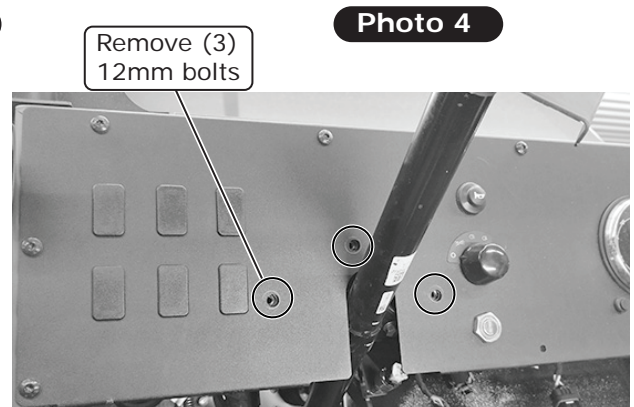

Photo 6



www.vintageair.com

Passenger Compartment Disassembly (Cont.)

7. Remove (11) T-30 bolts from the perimeter of the dash, then carefully remove by lifting the dash up and away from the cowl (See Photo 7, below).

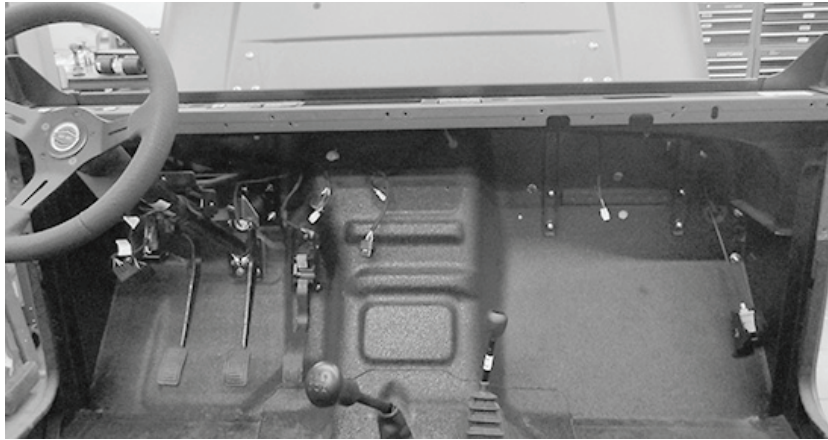

Dash Removed

Photo 7

Engine Compartment Disassembly

1. Disconnect the battery.
2. Using the proper clamp pliers, remove the spring clamp and crank case vent hose (See Photo 1, below).
3. Remove the air box clamp (See Photo 2, below), and the turbo inlet clamp (See Photo 3, below).
4. Remove the entire air box assembly (See Photo 4, below).

Remove spring clamp and crank case vent hose

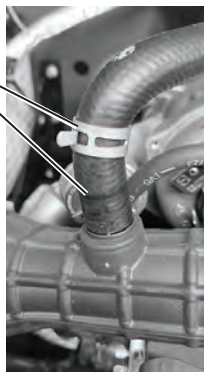
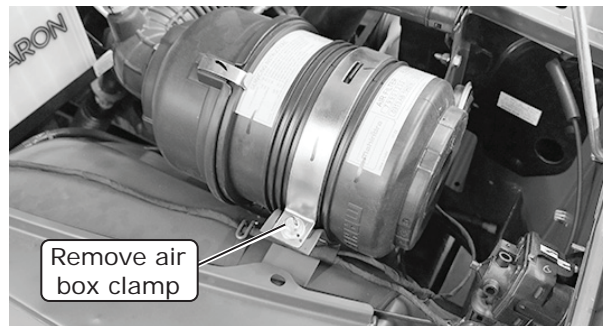

Photo 1



Remove air box clamp

Photo 2

Remove turbo inlet clamp

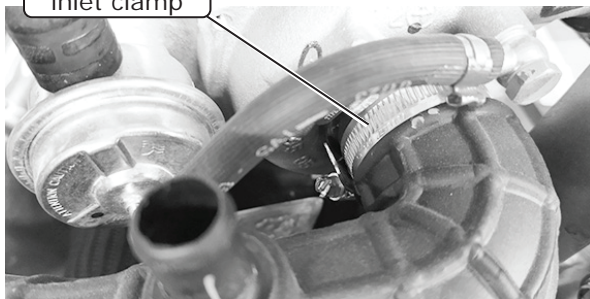
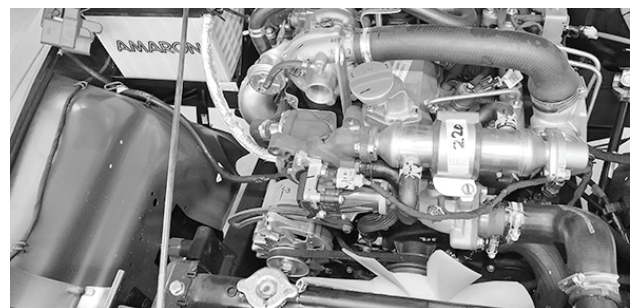

Photo 3



Air Box Assembly Removed

Photo 4

Engine Compartment Disassembly (Cont.)

5. Drain coolant through the petcock valve on the bottom of the radiator (See Photo 5, below).
NOTE: The following steps are recommended to make the later heater hose modification and fan shroud installation steps easier.
6. Remove the core support rods by removing the jam nuts on the front, and the nuts and bolts on the rear of both rods (See Photos 6 and 7, below).
7. Loosen the (4) radiator hose clamps (See Photo 8, below).
8. Remove the upper and lower radiator hoses (See Photo 8, below).
9. On the driver-side, disconnect the coolant reservoir hose (See Photo 9, below) and remove the top bolt that secures the reservoir and radiator (See Photo 10, below).
10. Remove the lower radiator mounting bolt (See Photo 10, below).

Drain coolant through petcock valve on bottom of radiator

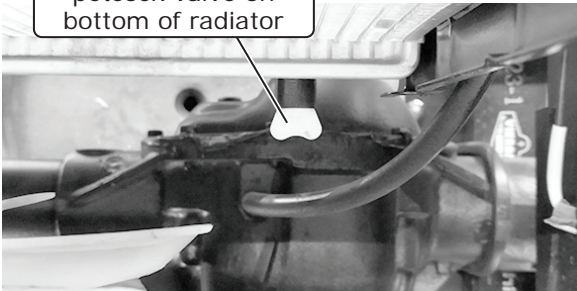

Photo 5

Remove core support rods by removing jam nuts on front, and nuts and bolts on rear of both rods

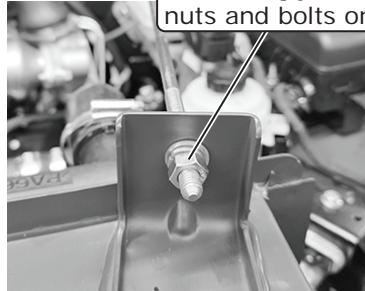

Photo 6

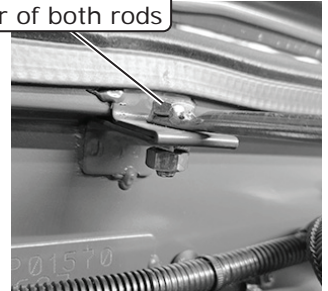
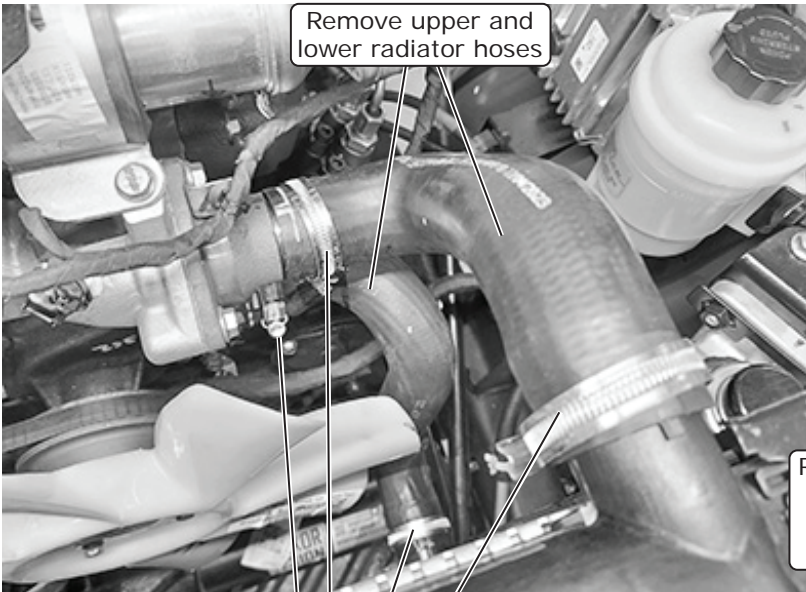

Photo 7

Remove upper and lower radiator hoses



Loosen (4) radiator hose clamps

Photo 8

Disconnect coolant reservoir hose



Photo 9

Remove top bolt that secures reservoir and radiator

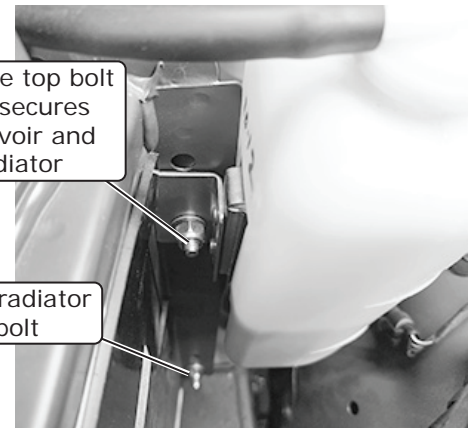

Remove lower radiator mounting bolt

Photo 10



www.vintageair.com

Engine Compartment Disassembly (Final)

11. On the passenger-side, remove the top bolt that secures the horn and radiator (See Photo 11, below).
12. Remove the lower radiator mounting bolt (See Photo 11, below).
13. Remove (4) mounting bolts from the radiator side brackets (See Photo 12, below).

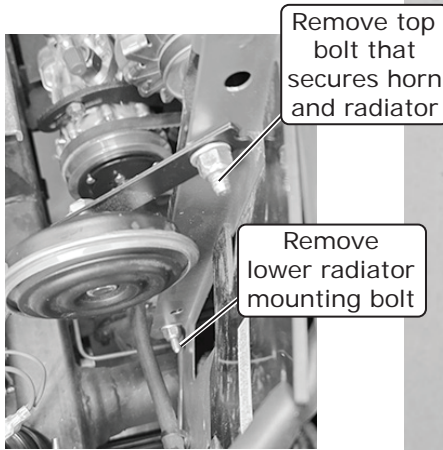

Photo 11

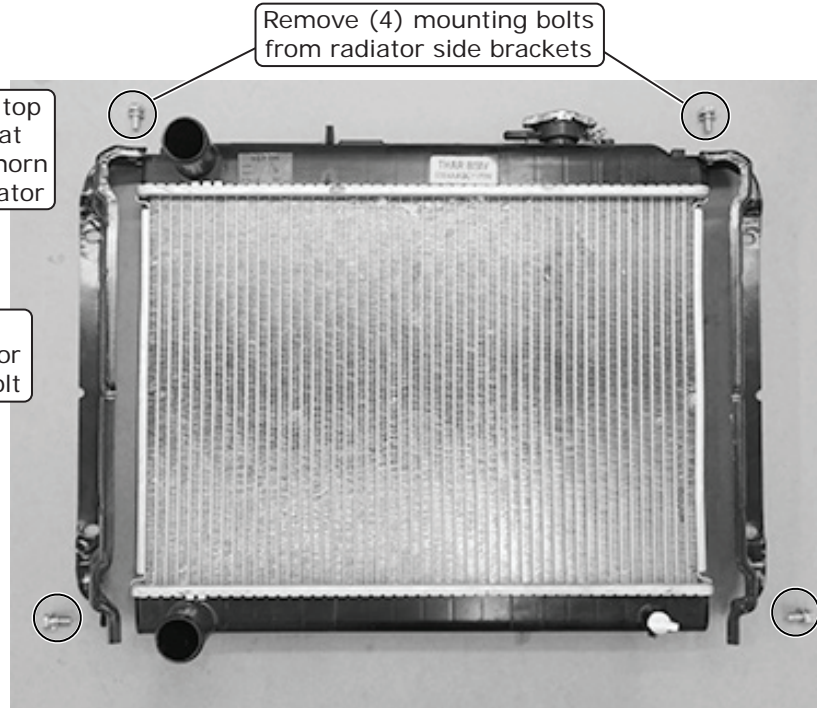

Photo 12

Heater Hose Modification

1. Locate the water pump heater line inlet hose (See Photo 1, below).
2. Disconnect the hose from the pump (See Photo 2, below). Remove and retain the hose clamp.

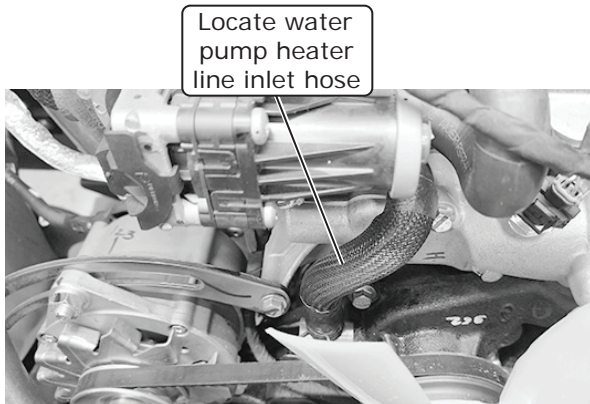

Photo 1

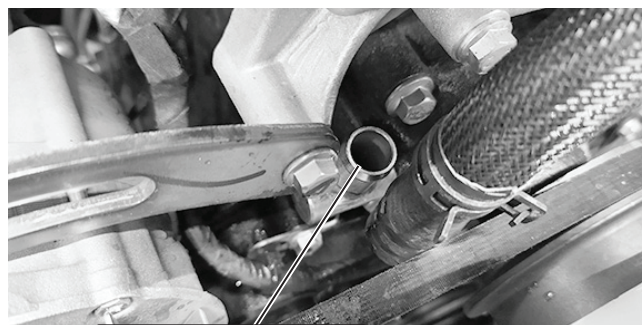

Photo 2



www.vintageair.com

Heater Hose Modification (Cont.)

3. Mark and cut the hose 3 ½" from the end (See Photos 3 and 4, below).
4. Install the 5/8" heater hardline straight splice and using proper clamp pliers, install the 5/8" hose clamp as shown in Photo 5, below.

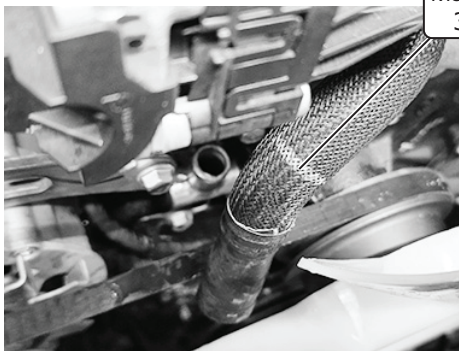

Photo 3

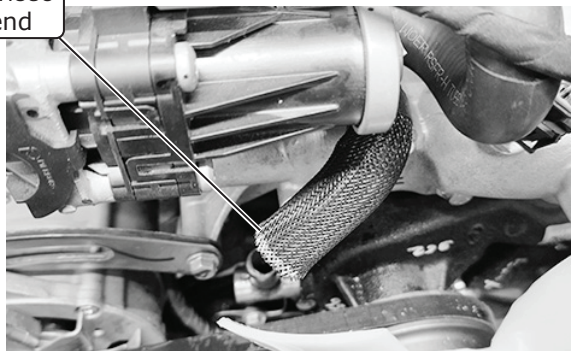

Photo 4

Install 5/8" heater hardline straight splice and 5/8" hose clamp

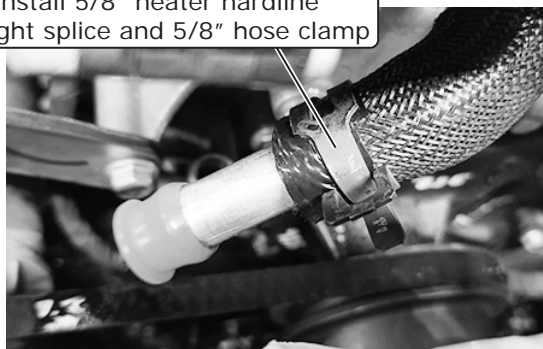

Photo 5

Compressor Installation

1. Refer to Compressor Installation instructions (159020).

Condenser Installation

1. Refer to Condenser Installation instructions (039020).



www.vintageair.com

Engine Compartment Modification

1. Temporarily relocate the wiring harness and vacuum line from the firewall area (See Photo 1, below).
2. Knockout (3) upper passenger-side holes in center of firewall (See Photo 2, below).
3. Locate (2) holes on the passenger-side firewall (See Photo 3, below).

NOTE: Temporarily relocate the wiring harness on the passenger-side firewall in the cab to prevent damage for the following step.

4. Knock out and enlarge both holes to 1 1/4" using a step bit (See Photos 4 and 5, below). Deburr and paint the holes after drilling (See Photo 5, below).
5. **For 2018 Manual Transmission Models Only:** Cut out the template provided on Page 35, and drill holes in the firewall for the driver side evaporator mounting.

Temporarily relocate wiring harness and vacuum line from firewall area

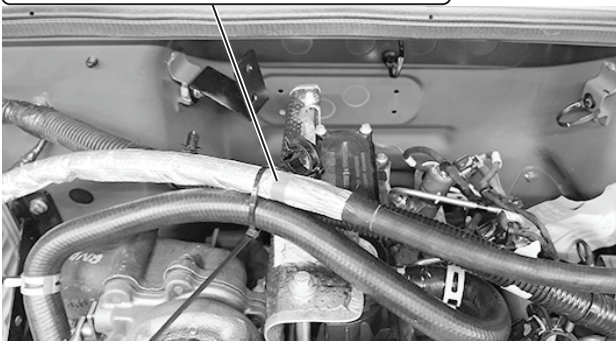

Photo 1

Knockout (3) upper passenger-side holes in center of firewall

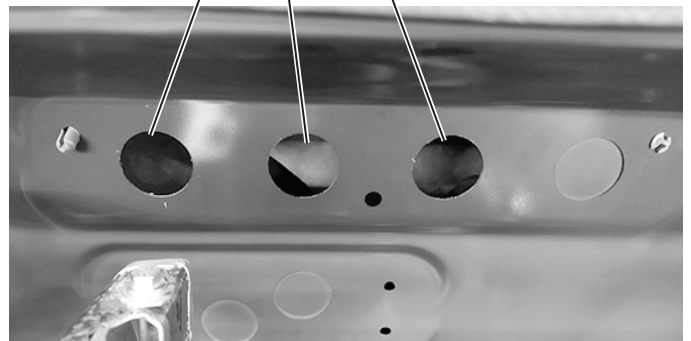

Photo 2

Locate (2) holes on passenger-side firewall

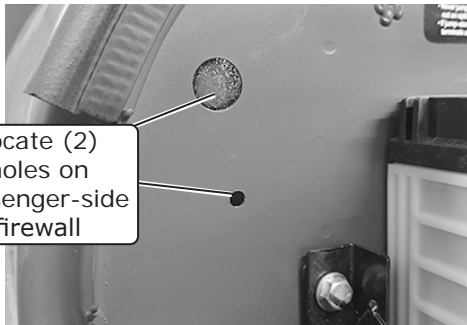

Photo 3

Step Bit



Photo 4

Deburr and paint holes after drilling

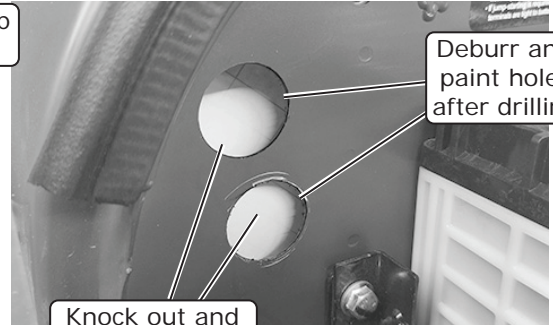

Knock out and enlarge both holes to 1.25" using a step bit

Photo 5



www.vintageair.com

Engine Compartment Preparation

1. Install the large grommet and 1 1/4" O.D. x 1" with 1/2" hole grommet into the previously drilled holes on the passenger-side firewall as shown in Photo 1, below.
2. Punch a 1/8" hole into the 1 1/4" x 1" grommet (See Photo 2, below).
3. Install (2) large grommets and a 1 1/4" x 1" grommet into the (3) center firewall holes as shown in Photo 3, below.
4. Locate the (2) passenger-side battery tray bolts and remove (See Photos 4 and 5, below).
5. Install (2) 9/32" flat washers and (2) 8mm x 35mm hex bolts into the passenger-side battery tray (See Photos 6 and 7, below).

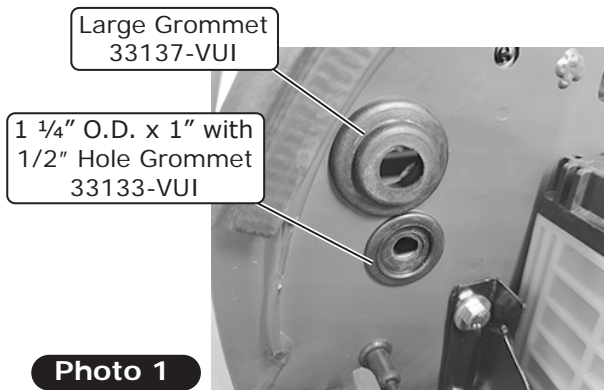

Photo 1

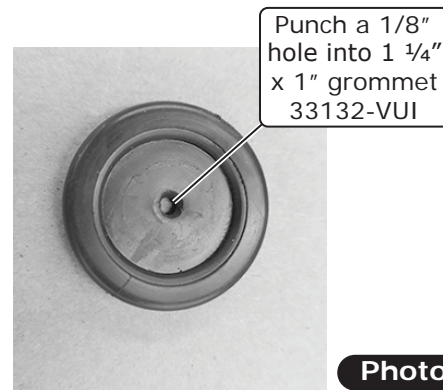

Photo 2

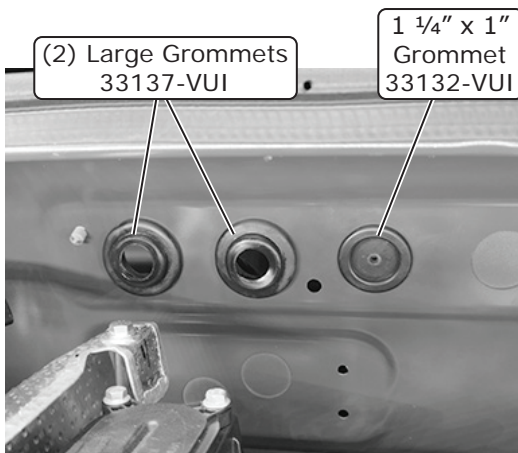

Photo 3



Photo 4



Photo 5

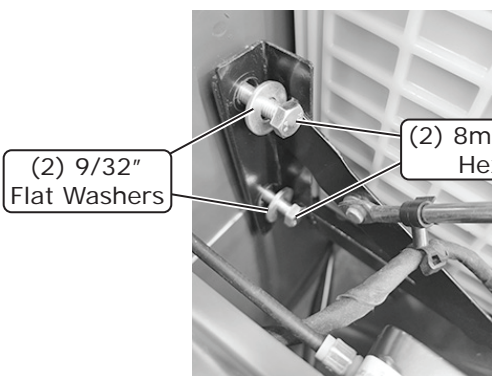

Photo 6

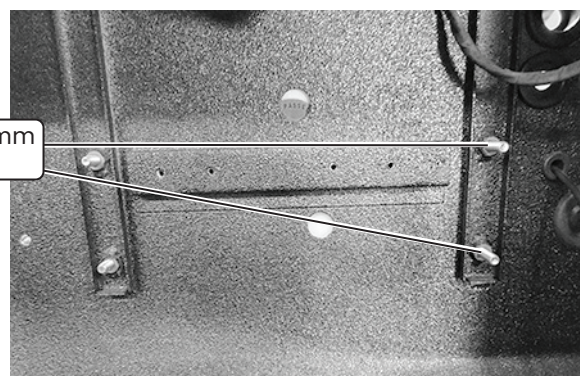

Photo 7



www.vintageair.com

Cowl Modification

NOTE: : Vehicle may have warning decals that may need to be relocated before cowl modification.

1. Leave the driver-side defrost cover on the vehicle (if equipped) (See Photo 1, below).
2. Remove the passenger side defrost cover (if equipped) (See Photo 2, below).
3. On the driver side of the cowl, measure and mark the front corner of the cowl 11 1/8" from outside of the cab (See Photo 3, below).
4. Place the defrost template on the cowl and center the template slot on the mark (See Photo 4, below).
5. Trace the pilot holes and outline onto the cowl (See Photo 5, below).
6. Drill the outer (2) holes to 5/16" for mounting holes (See Photo 6, below).

Leave driver-side defrost cover on vehicle

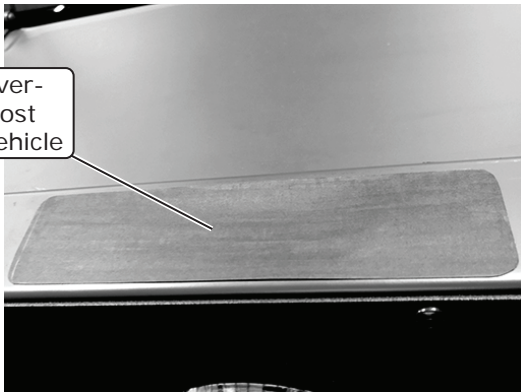

Photo 1

Remove passenger-side defrost cover

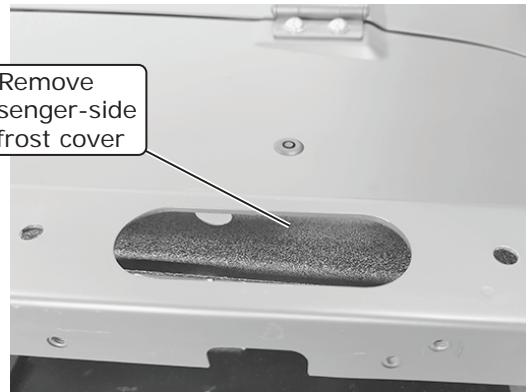

Photo 2

Measure and mark front corner of cowl 11 1/8" from outside of cab

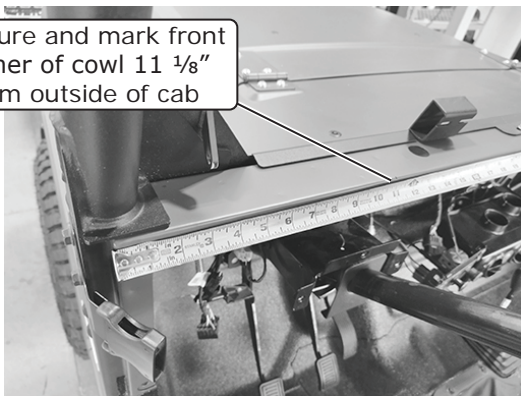

Photo 3

Place defrost template on cowl and center template slot on mark

Defrost Template 640653

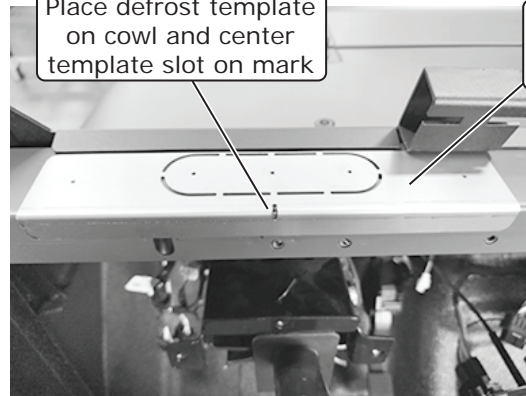

Photo 4

Trace pilot holes and outline onto cowl

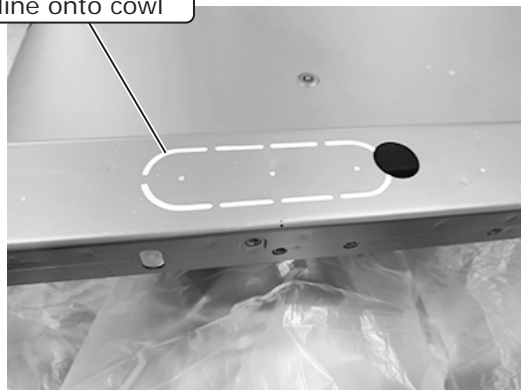

Photo 5

Drill outer (2) holes to 5/16" for mounting holes



Photo 6



www.vintageair.com

Cowl Modification (Cont.)

7. Drill 1/16" pilot for inside holes.
8. Using a 1 1/2" rotabroach, hole saw or step bit, drill the centermost holes for the defrost louver (See Photo 7, below).
9. Trim inside of remaining metal on cowl to clear the defrost louver hole (See Photo 8, below).
10. Repeat steps for the passenger side.



Photo 7

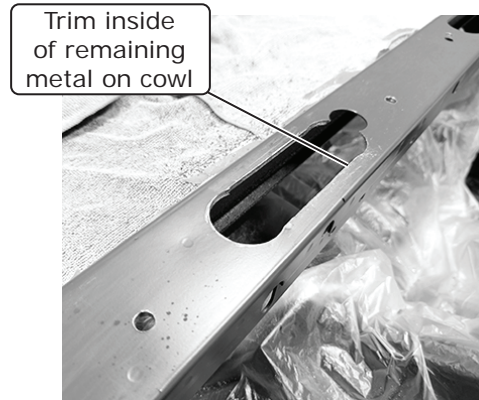

Photo 8

Evaporator Preparation

NOTE: For 2018 manual transmission models.

1. Remove (2) 10-32 x 1" screws and (2) 3/16" x 1/2" flat washers from the evaporator module (See Photo 1, below).
2. Install the center support subcase bracket onto the case on top of the existing evaporator bracket as shown in Photo 2, below. Secure with the removed bolts and washers (See Photo 2, below).
3. Install (2) M6 x 1 x 30mm hex bolts and (2) 1/4" pushnut bolt retainers onto the bracket as shown in Photo 3, below.

Remove (2) 10-32 x 1" screws and (2) 3/16" x 1/2" flat washers

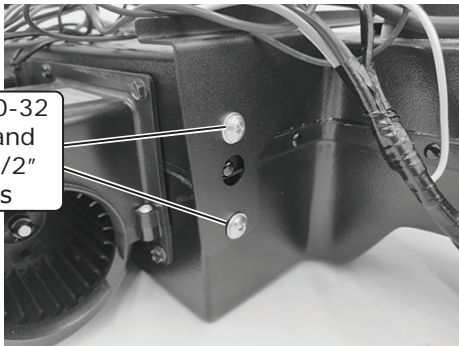

Photo 1

Center Support Subcase Bracket 640631

Secure with (2) 10-32 x 1" screws and (2) 3/16" x 1/2" flat washers

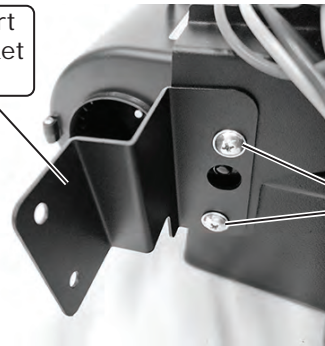

Photo 2

Install (2) M6 x 1 x 30mm hex bolts and (2) 1/4" pushnut bolt retainers



Photo 3



www.vintageair.com

Evaporator Preparation (Cont.)

NOTE: For 2019 and up models.

4. Remove (2) 10-32 x 1" screws and (2) 3/16" x 1/2" flat washers from the evaporator module (See Photo 4, below).
5. Install the center support bracket onto the case on top of the existing evaporator bracket as shown in Photo 5, below. Secure with the removed bolts and washers (See Photo 5, below).

Remove (2) 10-32 x 1" screws and (2) 3/16" x 1/2" flat washers

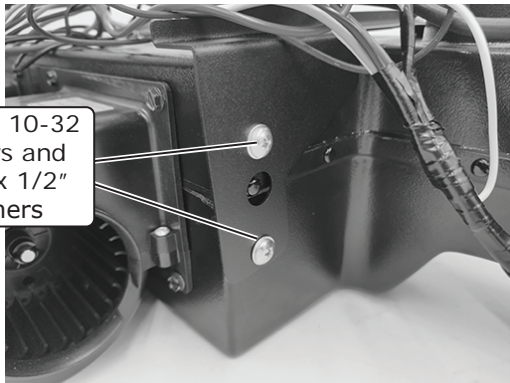
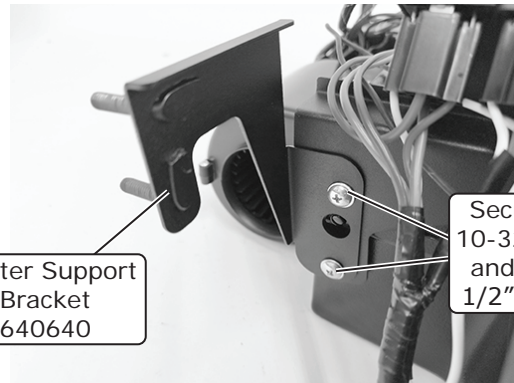

Photo 4

Center Support Bracket 640640



Secure with (2) 10-32 x 1" screws and (2) 3/16" x 1/2" flat washers

Photo 5

Defrost Louver Installation

1. Install the defrost louver into the defrost bracket (See Photo 1, below).
2. Install louver assembly into previously cut hole in cowl (See Photo 2, below).
3. Secure with (2) M6 x 1 truss head screws, (2) 9/32" flat washers and (2) M6-1.0 locknuts (See Photo 3, below).
4. Repeat steps 1-3 on opposite side.

Defrost Bracket 640650

Black Louver 493550

Install defrost louver into defrost bracket

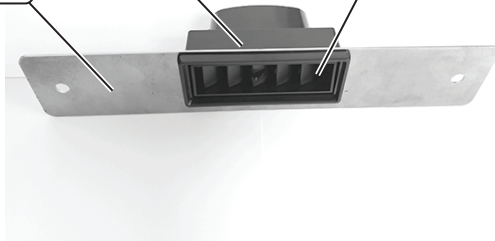

Photo 1

Install louver assembly into previously cut hole in cowl

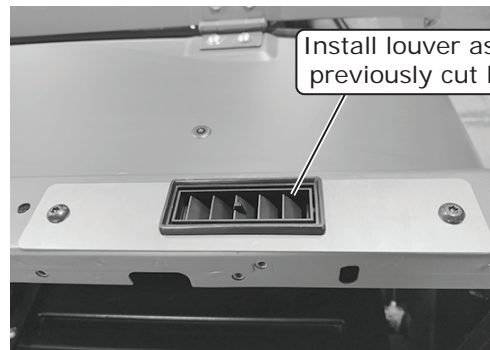

Photo 2

M6 x 1 Truss Head Screw

M6-1.0 Locknut

M6 x 1 Truss Head Screw

9/32" Flat Washer

M6-1.0 Locknut

9/32" Flat Washer



Photo 3



www.vintageair.com

Evaporator Installation

NOTE: On 2018 manual transmission models, the driver side evaporator bracket may need to be replaced with the center support bracket (640640).

NOTE: To ensure a watertight seal between the passenger compartment and the vehicle exterior, for all bolts passing through the firewall, Vintage Air recommends coating the threads with silicone prior to installation.

1. Locate the battery tray bolts installed during the engine compartment preparation.
2. Install the evaporator module onto the bolts and secure using (2) M8-1.25 locknuts and (2) 5/16" flat washers as shown in Photo 1, below.
3. Insert studs on the driver-side evaporator bracket into the corresponding holes on the firewall (See Photo 2, below). Secure from the engine bay side using (2) 9/32" flat washers and (2) M6-1.0 locknuts as shown in Photo 3, below.
4. Install (4) M6 x 1 U-nuts onto the control panel and evaporator bracket slots (See Photos 4, 5 and 6, below).

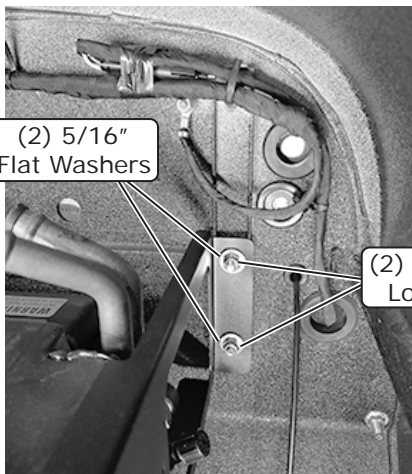

(2) 5/16"
Flat Washers

(2) M8-1.25
Locknuts

Photo 1

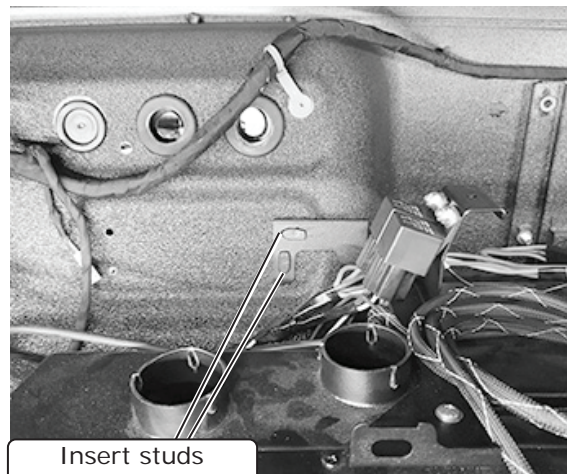

Insert studs
on driver-side
evaporator bracket
into corresponding
holes on firewall

Photo 2

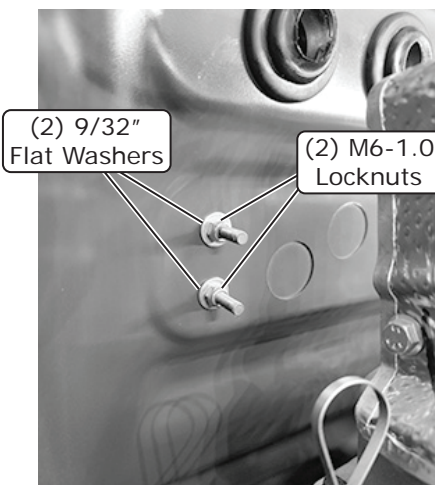

(2) 9/32"
Flat Washers

(2) M6-1.0
Locknuts

View from
Engine Bay Side

Photo 3

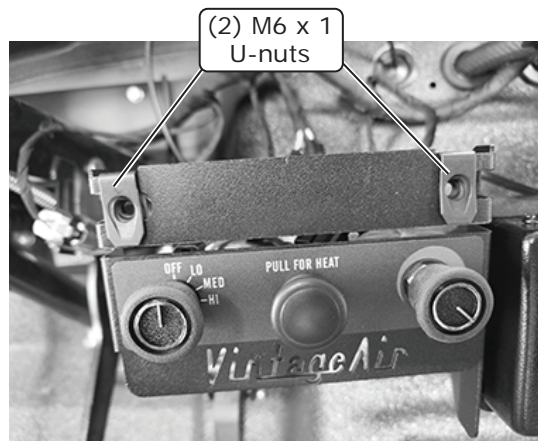

(2) M6 x 1
U-nuts

Photo 4

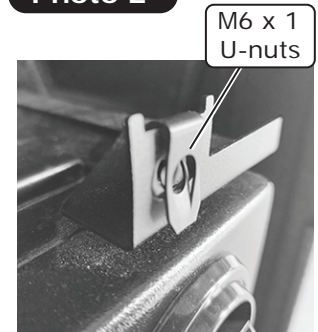

M6 x 1
U-nuts

Photo 5

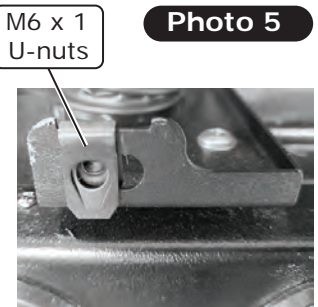

M6 x 1
U-nuts

Photo 6



www.vintageair.com

Drain Hose Installation

1. Locate and knock out the drain hose hole on the passenger-side floor pan, located underneath the battery tray (See Photo 1, below).
2. If not equipped, drill a 5/8" hole 12" up from the passenger-side floor pan and 16 1/4" to the left of the passenger-side kick panel (See Photo 2, below).
3. Install the drain hose into the 5/8" hole and connect it to the drain nipple on the evaporator module (See Photo 3, below).

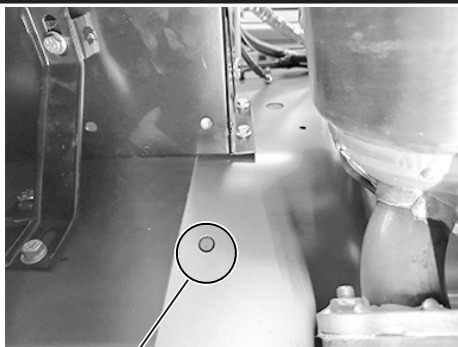

Locate and knock out drain hose hole on passenger-side floor pan

Photo 1

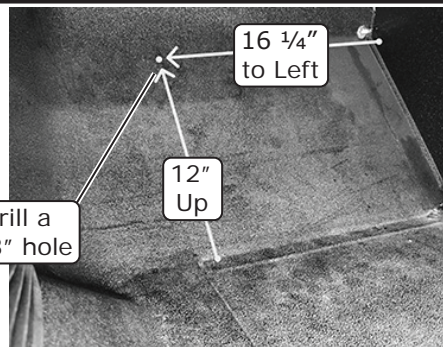

Drill a 5/8" hole

16 1/4" to Left

12" Up

Photo 2



Install drain hose into 5/8" hole and connect to drain nipple

Photo 3

Heater Hose & Heater Control Valve Installation

1. Install the heater hose support bracket using (2) M8 x 1.25 x 14mm hex bolts as shown in Photos 1, 2 and 3, below.

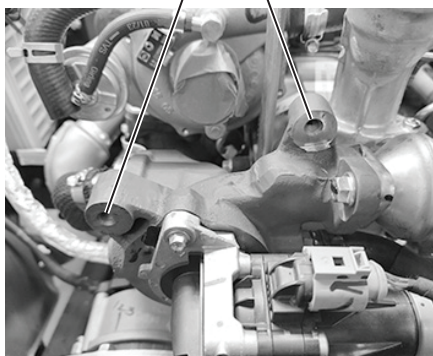

Install heater hose support bracket

Photo 1

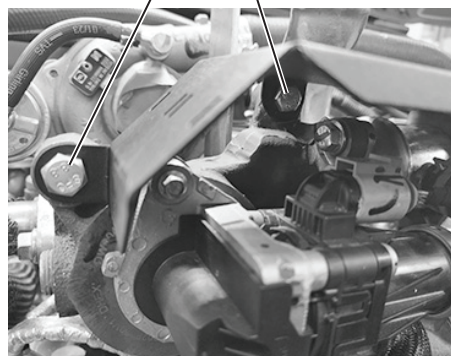

(2) M8 x 1.25 x 14mm Hex Bolts

Photo 2

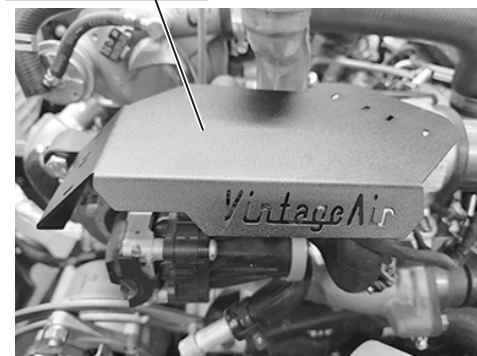

Heater Hose Support Bracket 640651

Photo 3



www.vintageair.com

Heater Hose & Heater Control Valve Installation (Cont.)

2. Cut (4) lengths of heater hose: 28", 31", 34" and 37".
3. Connect the 31" length of hose to the outlet port on the heater control valve. Secure with a 5/8" hose clamp (See Photo 4, below).
4. Connect the 28" length of hose to the inlet port on the heater control valve. Secure with a 5/8" hose clamp (See Photo 5, below).
5. Route the open hose ends underneath the air intake hose toward the front of the motor (See Photo 6, below).
6. Attach the open end of the 31" length of hose to the water pump inlet port. Secure with a 5/8" hose clamp (See Photo 7, below).
7. Connect the open end of the 28" length hose to the barbed splice installed on the previously cut hose. Secure with a 5/8" hose clamp (See Photo 8, below).
8. From inside the cab, connect the 34" length of hose to the evaporator heater line closest to the firewall. Feed the other end through the right most hole in the center of the firewall. Secure with a 5/8" hose clamp (See Photo 9, below).

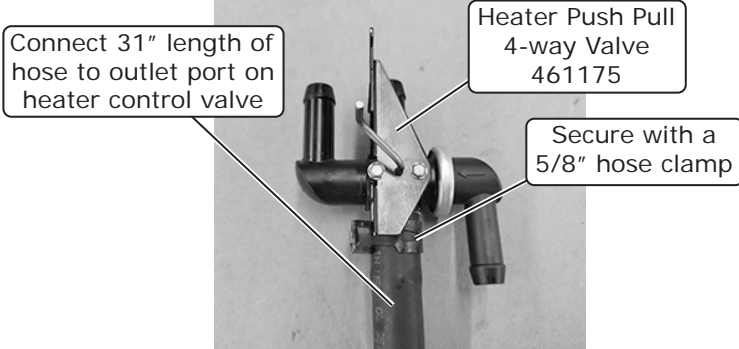

Photo 4

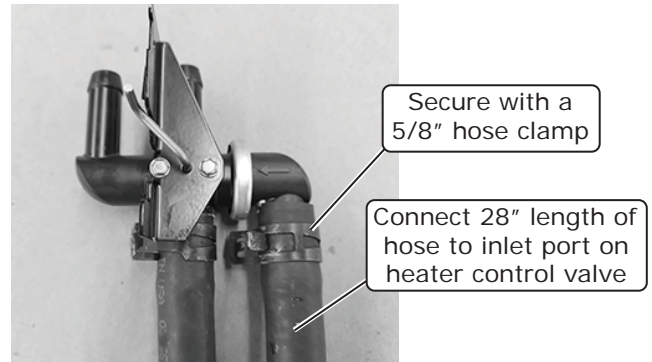

Photo 5

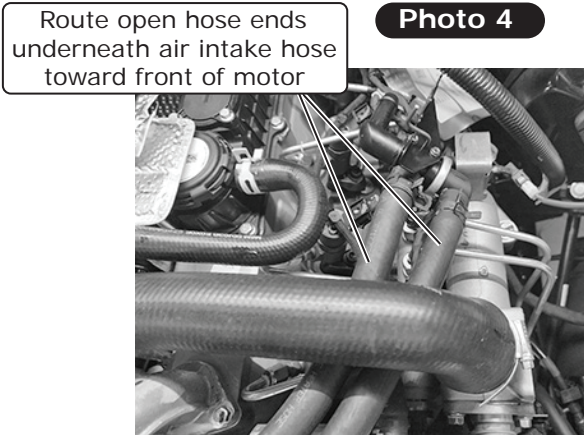

Photo 6

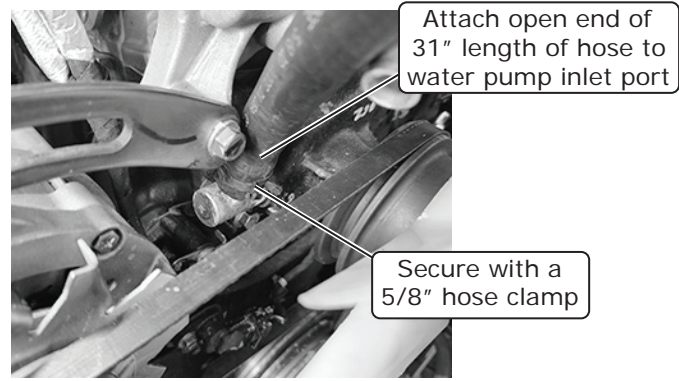

Photo 7

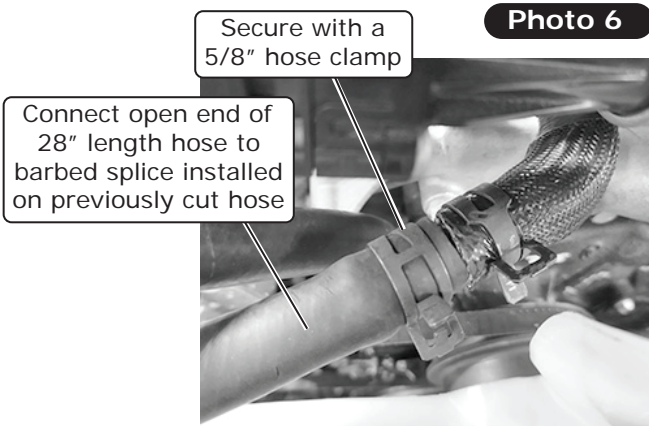

Photo 8

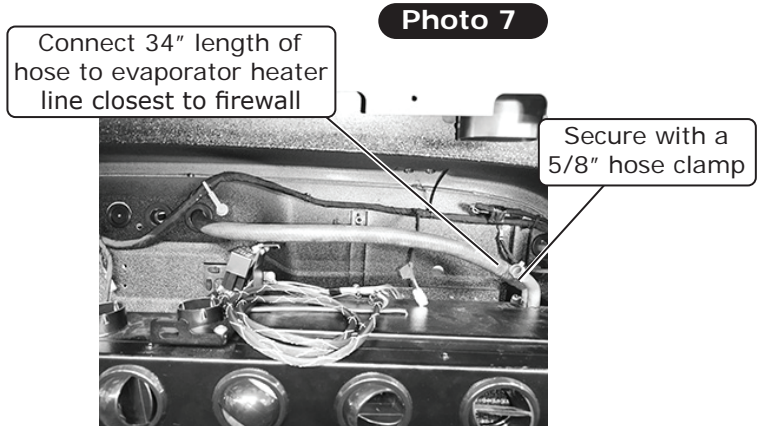

Photo 9



www.vintageair.com

Heater Hose & Heater Control Valve Installation (Cont.)

9. Connect the 37" length of hose to the evaporator heater line closest to the dash, and feed through the next hole over. Secure with a 5/8" hose clamp (See Photo 10, below).
10. From the engine bay, connect the hoses coming through the firewall to the corresponding ports on the heater control valve (See Photo 11, below).
11. Once all the hoses are routed and connected, secure the hoses inside the cab to the bracket on the evaporator using 11" tie wraps as shown in Photo 12, below.
12. Remove the nut from the heater control cable (See Photo 13, below).
13. Install the cable through the control panel (See Photo 14, below).
14. Install the nut back onto the cable and tighten on the back of the bracket (See Photo 15, below).
15. Loop the cable and install it through the grommet into the engine bay as shown in Photo 16, below.
16. Install the .188" O.D. x .125" I.D. x .336" length nylon spacer onto the heater control valve lever (See Photo 17, below).
17. Install the cable onto the spacer (See Photo 18, below).

Connect 37" length of hose to evaporator heater line closest to dash

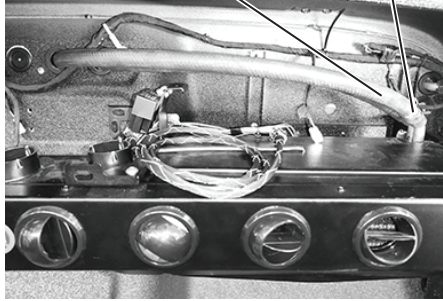

Secure with a 5/8" hose clamp

Photo 10

Connect hoses coming through firewall to corresponding ports on heater control valve

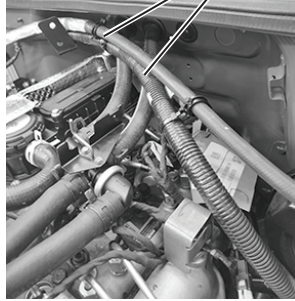

Photo 11

Secure hoses to bracket on evaporator using 11" tie wraps

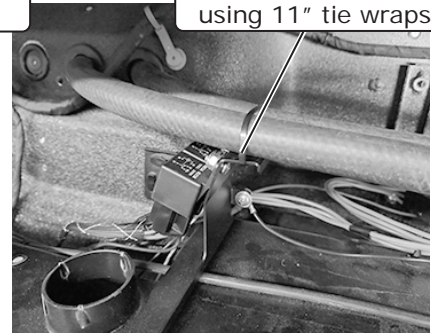

Photo 12

Remove nut from heater control cable

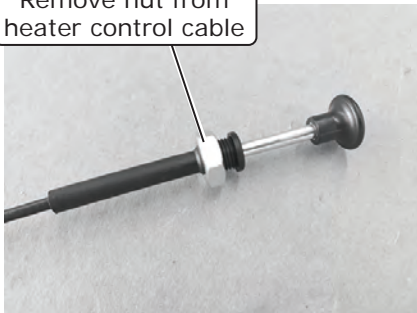

Photo 13

Install cable through control panel

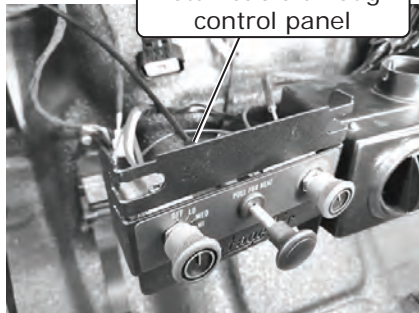
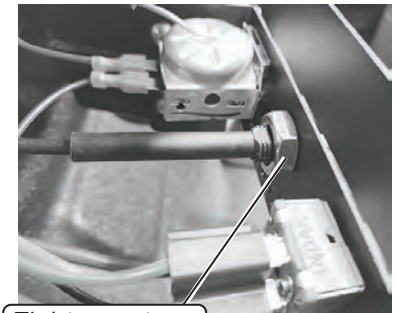

Photo 14



Tighten nut on back of bracket

Photo 15

Loop and install cable through grommet

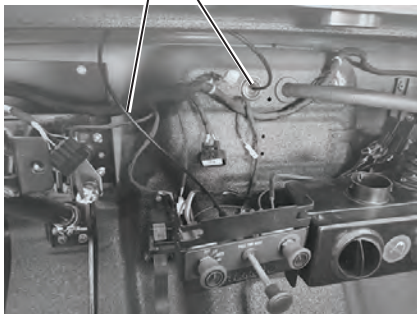

Photo 16

Install .188" O.D. x .125" I.D. x .336" length nylon spacer

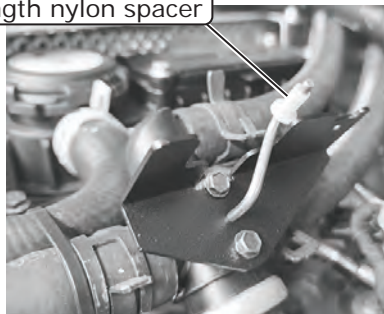

Photo 17

Install cable onto spacer

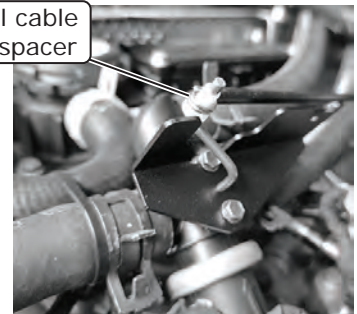

Photo 18



www.vintageair.com

Heater Hose & Heater Control Valve Installation (Final)

18. Install a 1/8" push-on ring onto the lever to secure the cable (See Photo 19, below).
19. Install a cable clip onto the cable (See Photo 20, below).
20. Secure the cable clip to the bracket using a #10 x 1/2" sheet metal screw (See Photo 21, below). Leave loose.
21. Adjust the cable so that the valve is completely closed when the cable is pushed in. Tighten the screw to secure the cable.

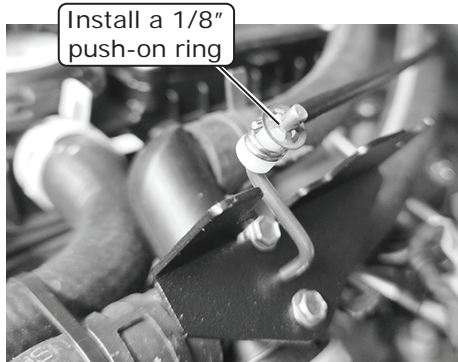

Install a 1/8" push-on ring

Photo 19

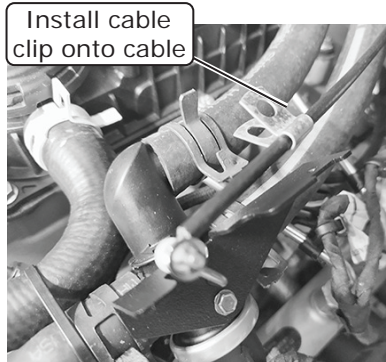

Install cable clip onto cable

Photo 20

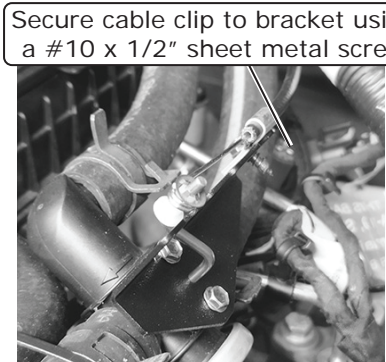

Secure cable clip to bracket using a #10 x 1/2" sheet metal screw

Photo 21

Lubricating O-rings

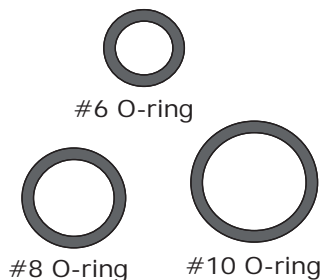

#6 O-ring

#8 O-ring

#10 O-ring

NOTE: Standard torque specifications:
 #6: 11 to 13 ft-lb.
 #8: 15 to 20 ft-lb.
 #10: 21 to 27 ft-lb.

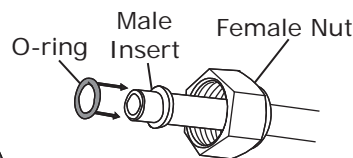

O-ring Male Insert Female Nut

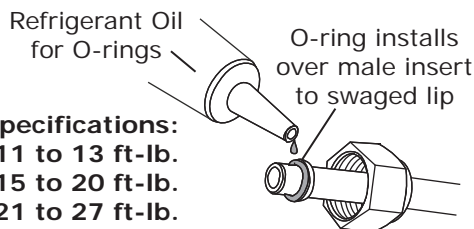

Refrigerant Oil for O-rings

O-ring installs over male insert to swaged lip

For a proper seal of fittings: Install supplied O-rings as shown and lubricate with refrigerant oil.

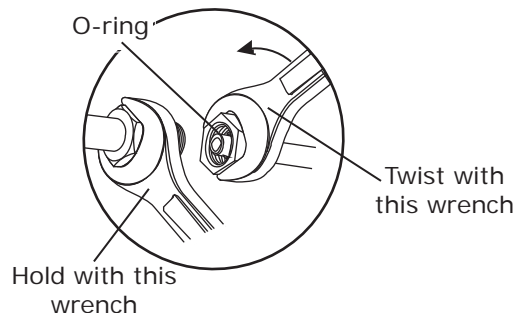

O-ring

Twist with this wrench

Hold with this wrench

Properly Seated O-ring Land

When installing a hardline or A/C hose fitting onto the evaporator module, ensure the O-ring land is seated properly (See Photo 1, below). An improperly seated O-ring land (See Photo 2, below) can cause a leak. To properly install the fitting, slide the hardline or A/C hose nut back to expose the O-ring land and seat it onto the evaporator module fitting. Then, slide the hardline or A/C hose nut forward and thread it onto the evaporator module fitting, ensuring the O-ring land does not move or lift.

Properly Seated O-ring Land



Photo 1

Improperly Seated O-ring Land



Photo 2

NOTE: Photos shown are for reference only. Fittings may vary depending on kit received.



www.vintageair.com

Fan Shroud Assembly & Installation

NOTE: Perform the following on a workbench.

1. Figure 1, below, shows the radiator, brackets, and fan shroud in exploded view.
2. Place the upper fan shroud on the radiator as shown in Figure 2, below. **NOTE: The shroud should rest on the radiator via the (4) round landings on the sides.**
3. Install the OEM brackets onto the radiator (See Figure 3, below).
4. Secure the brackets with (4) OEM bolts as shown in Figures 3 and 4, below.

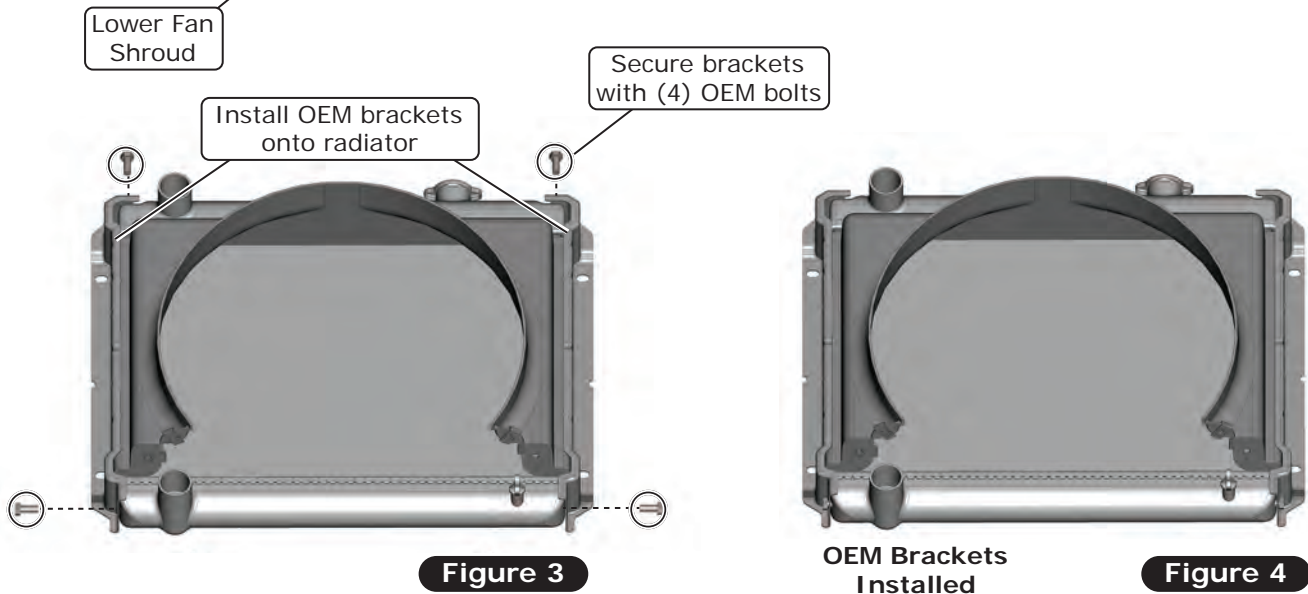
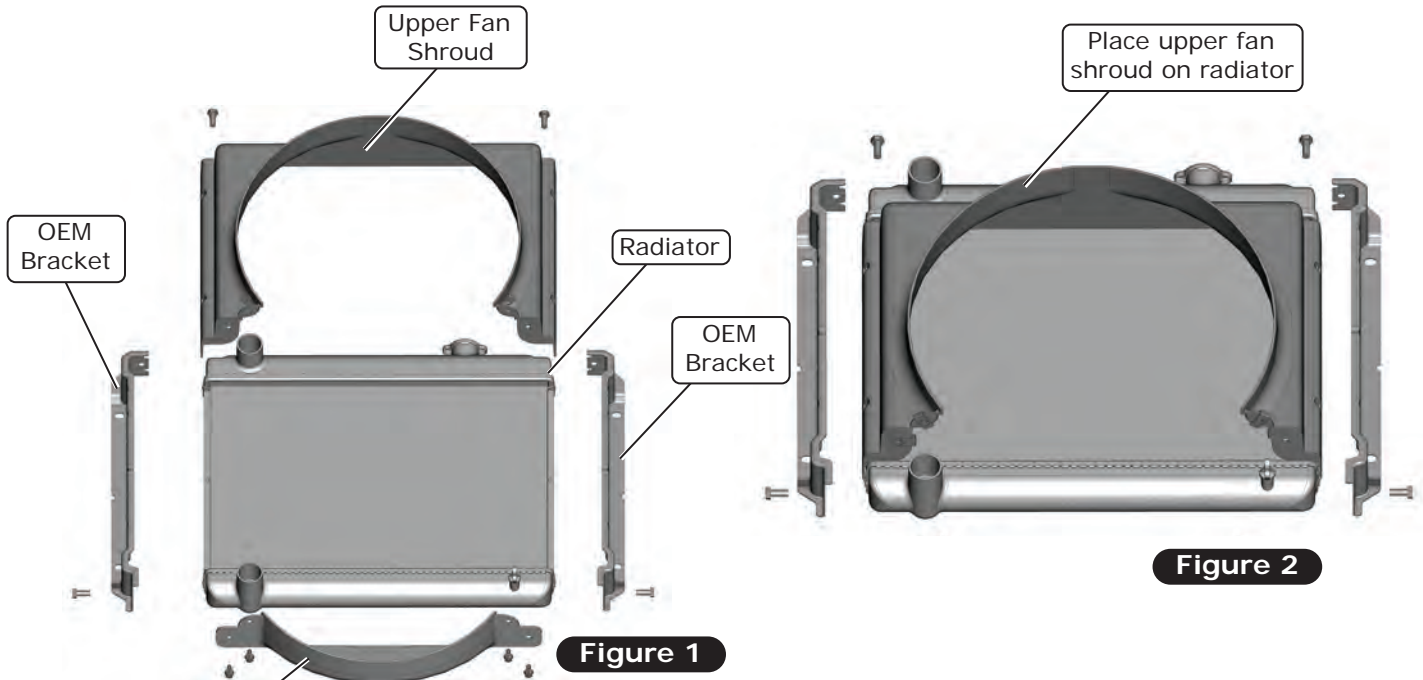



www.vintageair.com

Fan Shroud Assembly & Installation (Cont.)

NOTE: The following steps are to be performed on the vehicle.

5. Install the radiator and shroud assembly into the vehicle using the OEM hardware. **NOTE: Heater hose bracket may need to be loosened.**
6. Install the lower fan shroud onto the shroud assembly (See Figure 5, below).
7. Secure the lower fan shroud with (4) 1/4-20 x 1/2" hex bolts into the U-Nuts (See Figures 5 and 6, below).

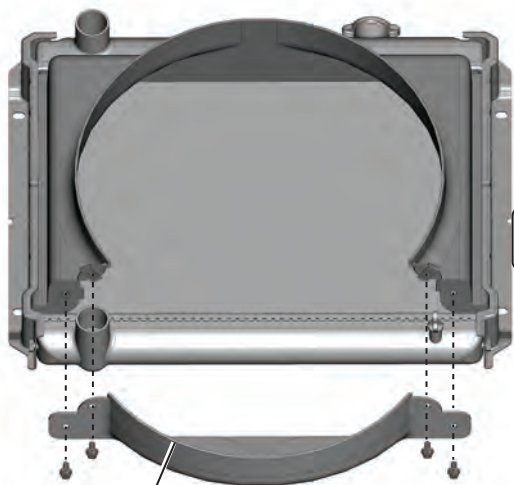

Figure 5

Install lower fan shroud onto shroud assembly

1/4-20 x 1" Length U-nut

1/4-20 x 1.2" Length U-nut

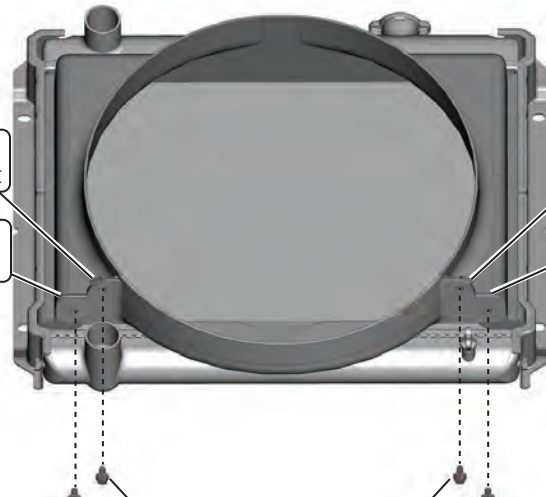
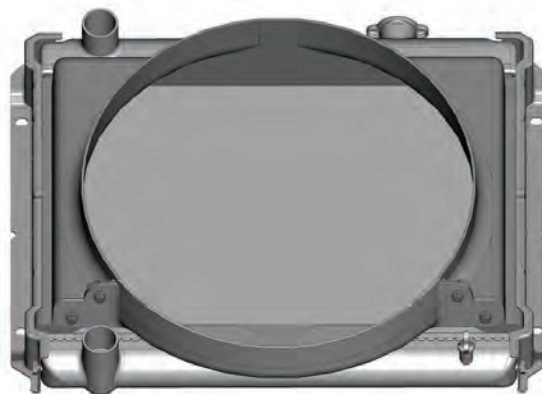

Figure 6

Install and secure lower shroud with (4) 1/4-20 x 1/2" hex bolts into U-nuts



Installation Complete

Figure 7



www.vintageair.com

A/C Hose Installation

1. Remove the #8 cap from the compressor, and with a properly lubricated #8 O-ring (See Lubricating O-rings, Page 20), connect the straight service port fitting of the #8 A/C hose to the compressor block fitting as shown in Photo 1, below.
2. Route the hose through the air cleaner bracket as shown in Photo 2, below.
3. With a properly lubricated #8 O-ring (See Lubricating O-rings, Page 20), connect the #8 A/C hose from the compressor to the upper fitting on the condenser (See Photo 2, below).
4. Remove the #10 cap from the compressor. With a properly lubricated #10 O-ring (See Lubricating O-rings, Page 20), connect the straight service port fitting of the #10 A/C hose to the compressor block fitting as shown in Photo 3, below. **NOTE: Check orientation of service ports.**
5. Remove the larger passenger-side firewall grommet, and install it onto the #10 A/C hose (See Photo 4, below), then reinstall the grommet as shown in Photo 5, below.

Connect straight service port fitting of #8 A/C hose

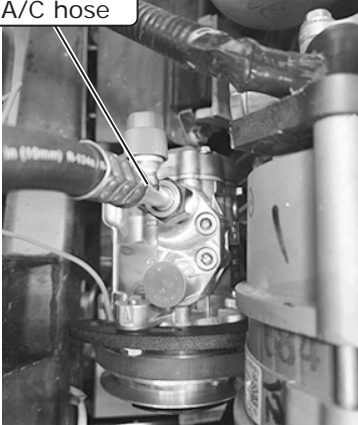
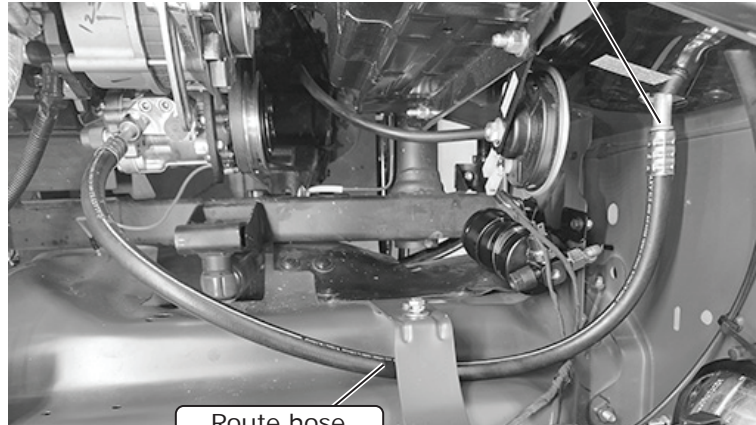

Photo 1

Connect #8 A/C hose from compressor to upper fitting on condenser



Route hose through air cleaner bracket

Photo 2

Connect straight service port fitting of #10 A/C hose

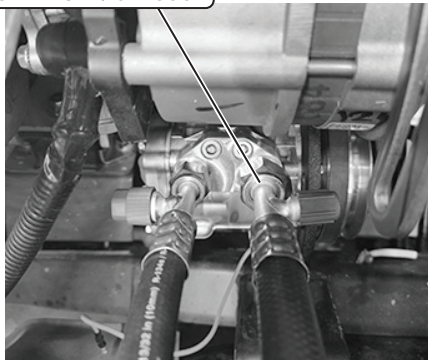

Photo 3

Remove larger passenger-side firewall grommet and install onto #10 A/C hose

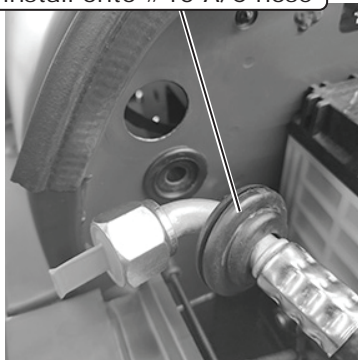

Photo 4

Reinstall grommet



Photo 5



www.vintageair.com

A/C Hose Installation (Cont.)

6. With a properly lubricated #10 O-ring (See Lubricating O-rings, Page 20), install the 90° fitting of the #10 A/C hose onto the evaporator module in the cab as shown in Photo 6, below.
7. From the engine bay, feed the 45° fitting of the #6 A/C hose through the smaller firewall grommet on the passenger side as shown in Photo 7, below.
8. With a properly lubricated #6 O-ring (See Lubricating O-rings, Page 20), install the 45° fitting of the #6 A/C hose onto the evaporator in the cab as shown in Photo 8, below.
9. Feed the opposite end of the #6 A/C hose through the air cleaner bracket and with a properly lubricated #6 O-ring (See Lubricating O-rings, Page 20), install the straight end onto the drier as shown in Photo 9, below.
10. The A/C hose routing should resemble the routing as shown in Photo 10, below.

Install 90° fitting of #10 A/C hose

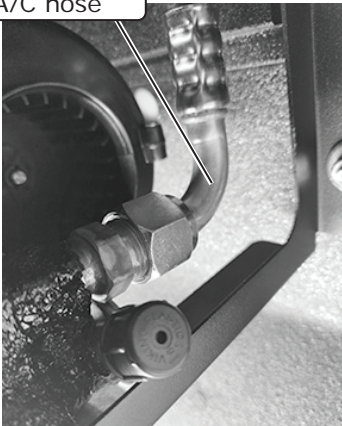

Photo 6

Feed 45° fitting of #6 A/C hose through smaller firewall grommet

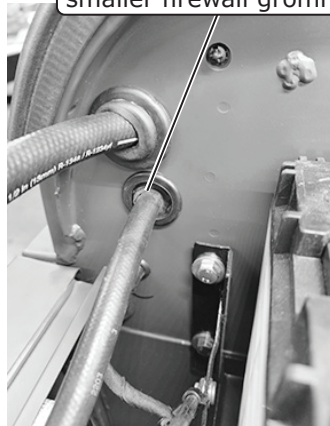
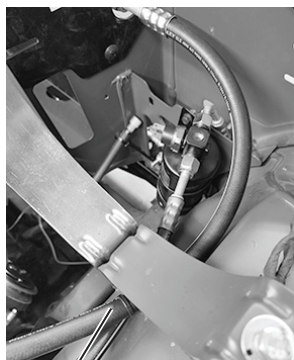

Photo 7

Install 45° fitting of #6 A/C hose onto evaporator

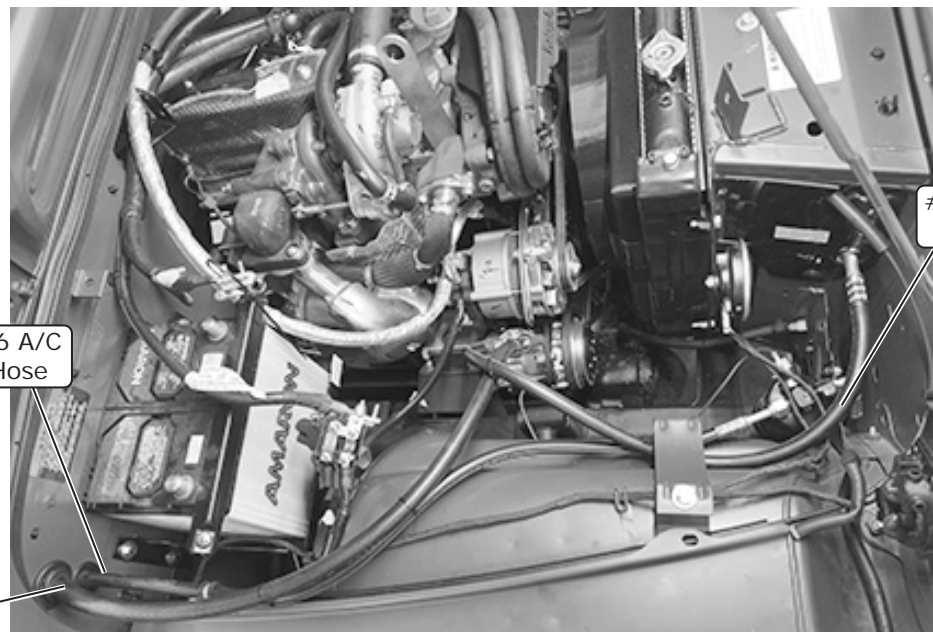

Photo 8



Feed opposite end of #6 A/C hose through air cleaner bracket

Photo 9



#8 A/C Hose

#6 A/C Hose

#10 A/C Hose

A/C Hose Routing shown

Photo 10



www.vintageair.com

A/C Hose Installation (Final)

11. Tighten the drier clamp.
12. Remove the nut from the hood release bracket bolt on the fender by the battery (See Photo 11, below)
13. Install an Adel clamp onto the #6 A/C hose and the hood release bracket bolt, then reinstall the previously removed nut (See Photo 12, below).
14. Secure the hoses to one another using the 11" tie wraps to prevent excessive play.

Remove nut from
hood release
bracket bolt

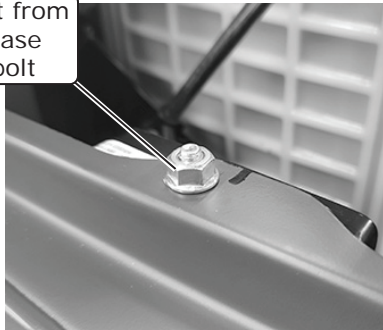

Photo 11

Reinstall
nut



Photo 12

Wiring Installation (Roxpower Equipped)

1. Locate the accessory port on the Roxpower module with a 20A fuse (See Photo 1, below).
2. Connect the evaporator wiring harness connector to the Roxpower module (See Photo 2, below).

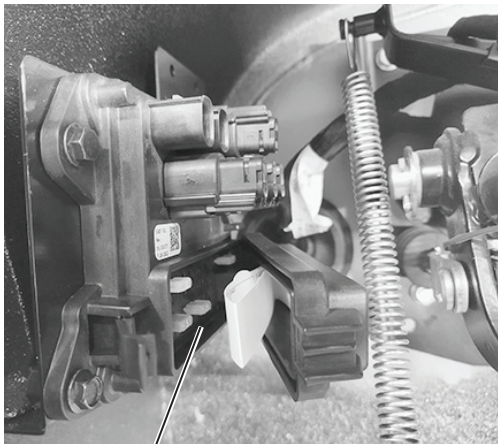

Locate accessory port
on Roxpower module
with a 20A fuse

Photo 1

Connect evaporator
wiring harness connector
to Roxpower module

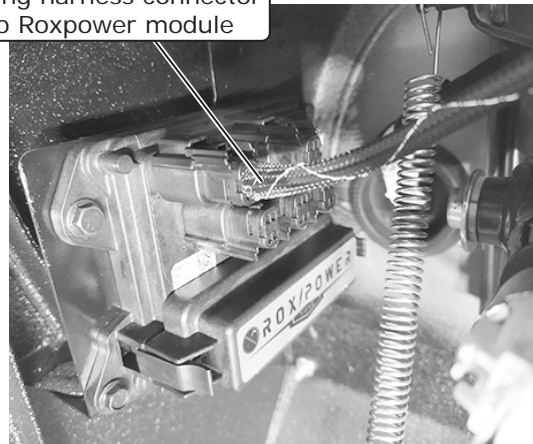

Photo 2



www.vintageair.com

Wiring Installation (Without Roxpower)

NOTE: See Quality Crimp Guidelines (Page 32), for all crimped connections.

1. Locate the cigarette lighter/12V power pigtail on the passenger side of the vehicle (See Photo 1, below).
2. Cut the violet/yellow stripe wire 3" behind the plug and strip both sides (See Photo 2, below).
3. Strip the violet wire of the wire assembly and twist together with the violet/yellow wire coming from the factory harness (See Photo 3, below). Using the 14GA end of the 14-12GA butt connector, crimp the violet and violet/yellow striped wires together (See Photo 3, below).
4. Using the heat shrink, crimp the plug end of the violet/yellow striped wire to the 12GA end of the 14-12GA butt connector (See Photo 4, below).
5. Install the ring terminal on the black wire from the wire assembly onto the ground stud on the passenger-side inner firewall (See Photo 5, below).
6. Route the red wire out of the #6 A/C hose grommet toward the battery (See Photo 6, below).

Locate cigarette lighter/12V power pigtail

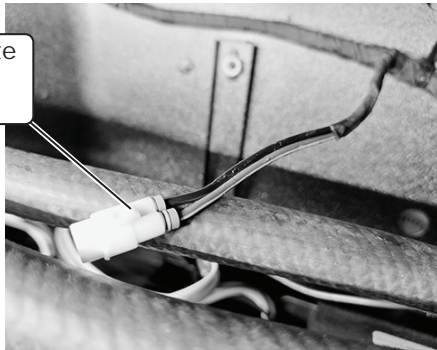

Photo 1

Cut violet/yellow stripe wire 3" behind plug and strip both sides

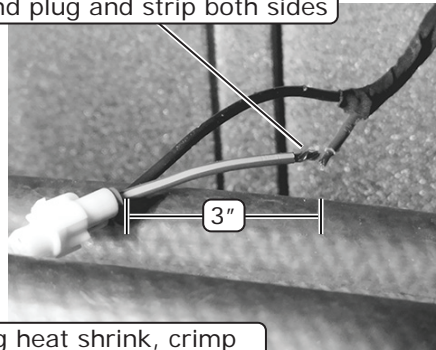

Photo 2

Crimp violet and violet/yellow striped wires together

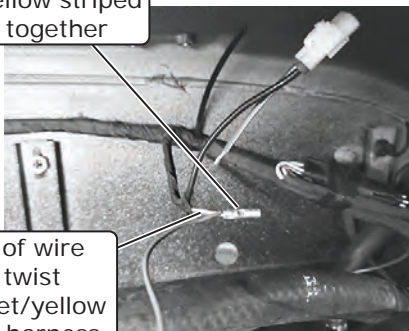

Photo 3

Using heat shrink, crimp plug end of violet/yellow striped wire to 12GA end of 14-12GA butt connector



Photo 4

Strip violet wire of wire assembly and twist together with violet/yellow wire from factory harness

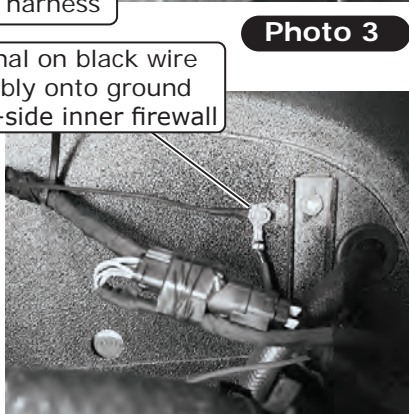

Photo 5

Install ring terminal on black wire from wire assembly onto ground stud on passenger-side inner firewall



Route red wire out of #6 A/C hose grommet toward battery

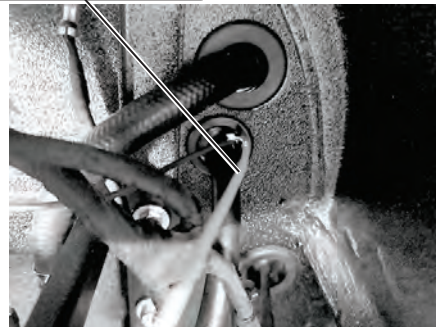

Photo 6



www.vintageair.com

Wiring Installation (Without Roxpower) (Cont.)

- Using heat shrink, crimp the red wire to the black fuse holder (See Photo 7, below).
- Connect the ring terminal from the fuse holder to the accessory terminal on the positive battery terminal (See Photo 8, below).
- Plug the wiring harness connector from the wiring assembly into the evaporator wiring harness connector (See Photo 9, below).

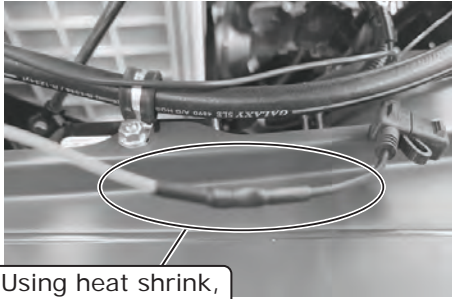

Using heat shrink, crimp red wire to black fuse holder

Photo 7

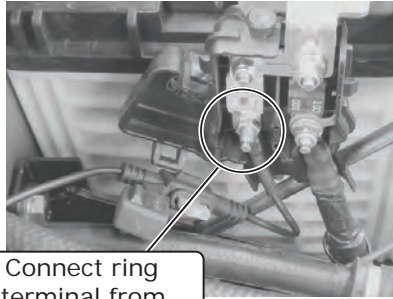

Connect ring terminal from fuse holder to accessory terminal on positive battery terminal

Photo 8

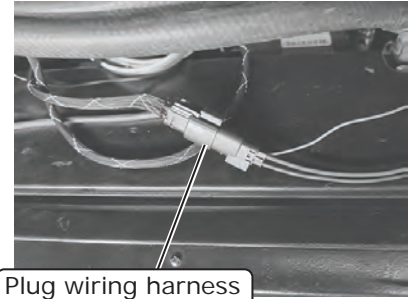

Plug wiring harness from wiring assembly into evaporator wiring harness connector

Photo 9

Safety Switch Wiring

- Locate the compressor lead. Measure and cut 24" from the bullet connector (See Photo 1, below).
- Strip and crimp the 16-14AWG 1/4" female terminal onto the cut end (See Photo 2, below).
- Attach the bullet connector to the compressor lead (See Photo 3, below).
- Route the compressor lead along the #8 A/C hose toward the safety switch. Connect to the switch (See Photo 4, below).

Compressor Lead
23135-VUW

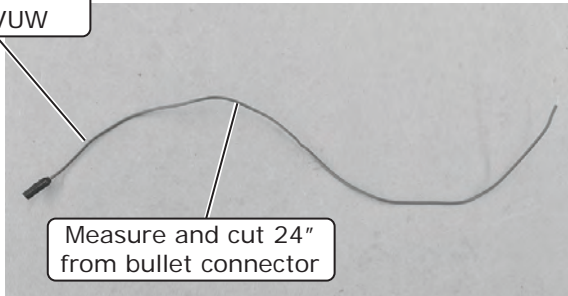

Measure and cut 24" from bullet connector

Photo 1

16-14AWG 1/4" Female Terminal
23172-VUW

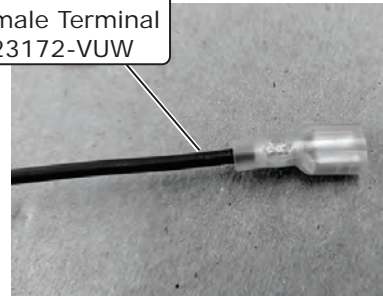

Connect compressor lead to safety switch

Photo 2

Attach bullet connector to compressor lead

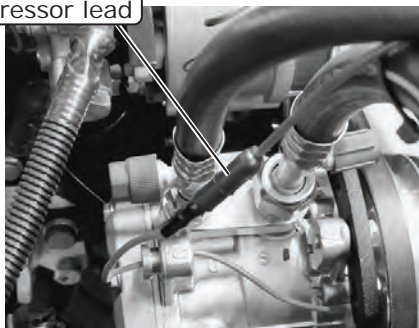

Photo 3

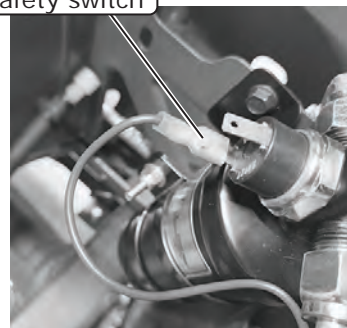

Photo 4



www.vintageair.com

Safety Switch Wiring (Cont.)

5. Locate the 72" blue jumper wire and connect it to the other terminal of the safety switch (See Photo 5, below).
6. Route the wire along the #6 A/C hose and through the grommet toward the control panel (See Photo 6, below).
7. Connect the wire to the thermostat switch (See Photo 7, below).
8. Secure the wires to the hoses using tie wraps.

Connect 72" blue jumper wire to other terminal of safety switch

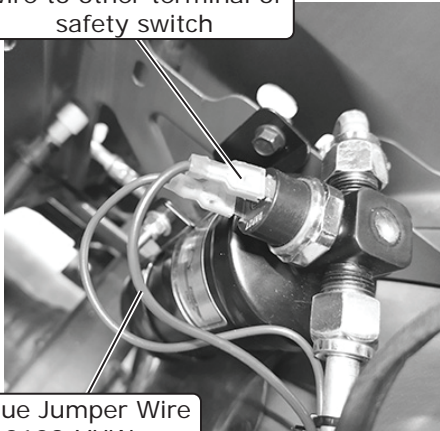

72" Blue Jumper Wire
23128-VUW

Photo 5

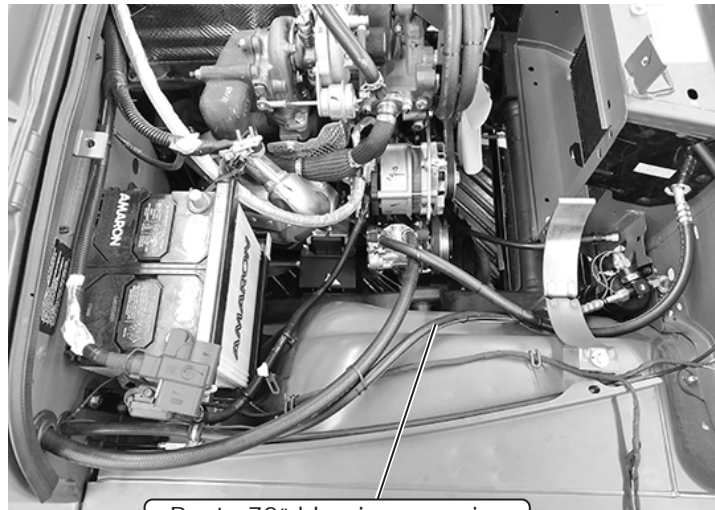

Route 72" blue jumper wire along #6 A/C hose through grommet toward control panel

Photo 6

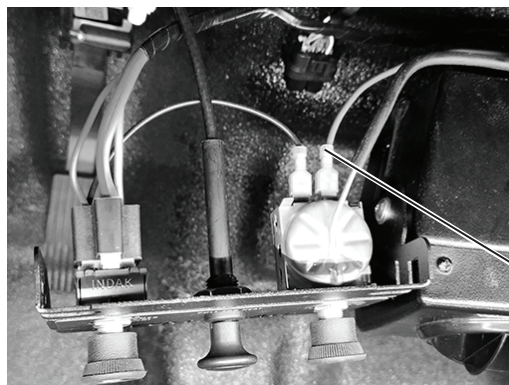

Connect 72" blue jumper wire to thermostat switch

Photo 7



www.vintageair.com

Defrost Duct and Hose Installation

1. Cut a 36" length of 2 1/2" duct hose for the driver-side duct (See Photo 1, below).
2. Install the duct hose onto the driver-side evaporator plenum and onto the driver-side louver.
3. Secure hoses to the evaporator with an 11" tie wrap (See Photo 2, below).
4. Install the remaining 24" length of duct hose onto the passenger side louver and evaporator plenum (See Photo 1, below).
5. Secure to the evaporator with an 11" tie wrap (See Photo 2, below).

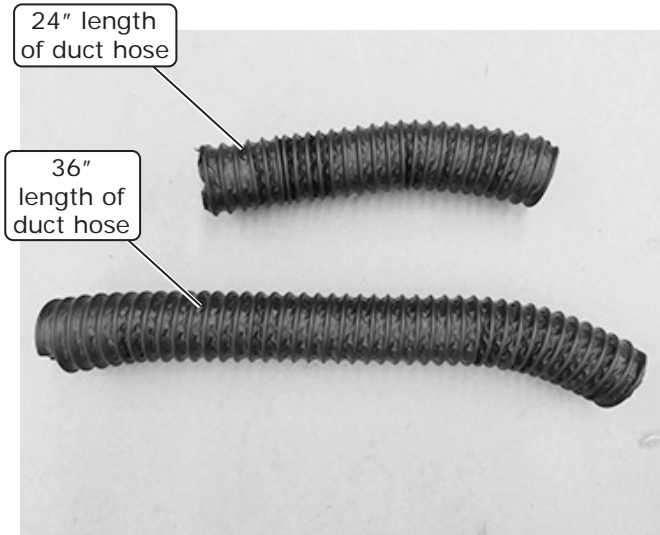

Photo 1

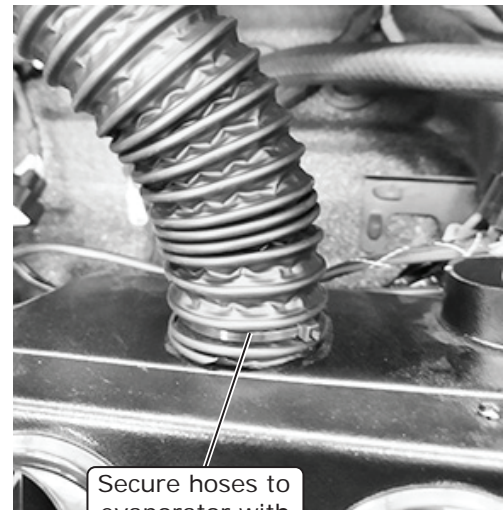

Photo 2

Dash Reassembly

1. Reinstall the dash using (2) M6 x 1 truss head screws in the mounting holes near the defrost ducts (See Photos 1 and 2, below).

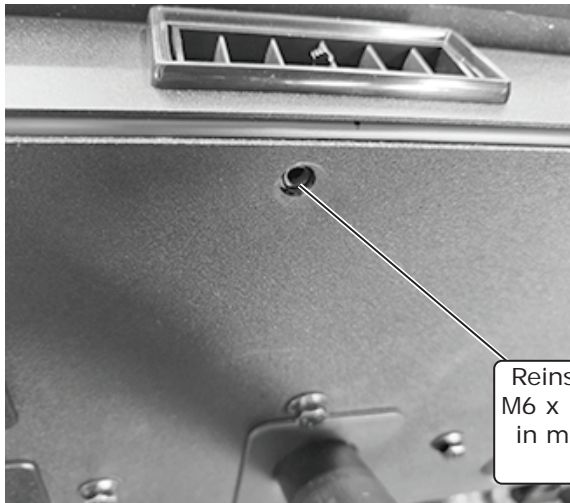

Photo 1

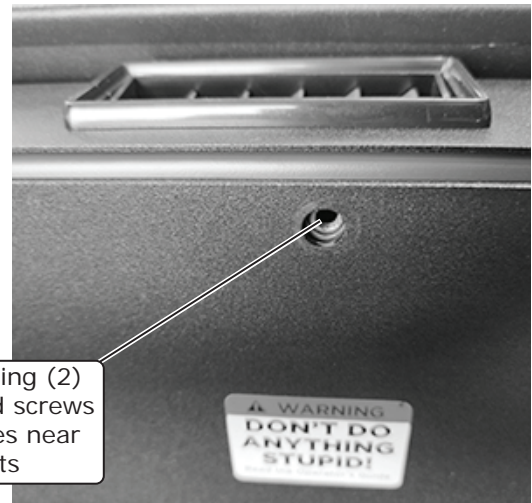

Photo 2



www.vintageair.com

Dash Reassembly (Cont.)

2. Use the remaining (2) M6 x 1 truss head screws to secure the control panel bracket (See Photo 3, below).
3. Secure the rest of the dash with the OEM hardware (See Photo 4, below).
4. Reconnect all previously removed and disconnected components.
5. Reconnect all previously removed accessories.

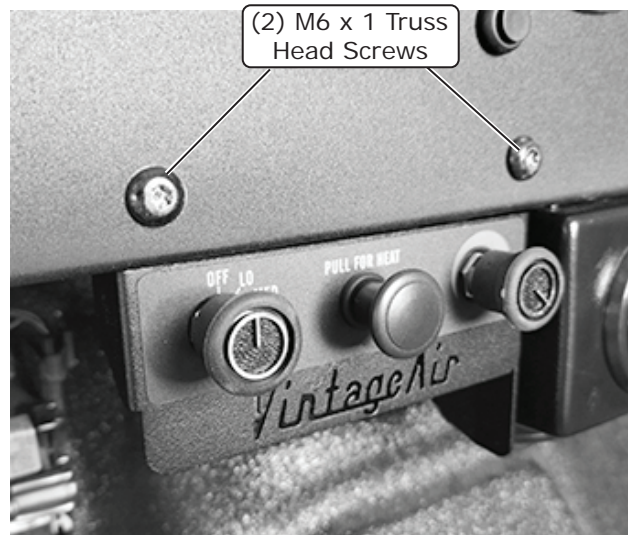
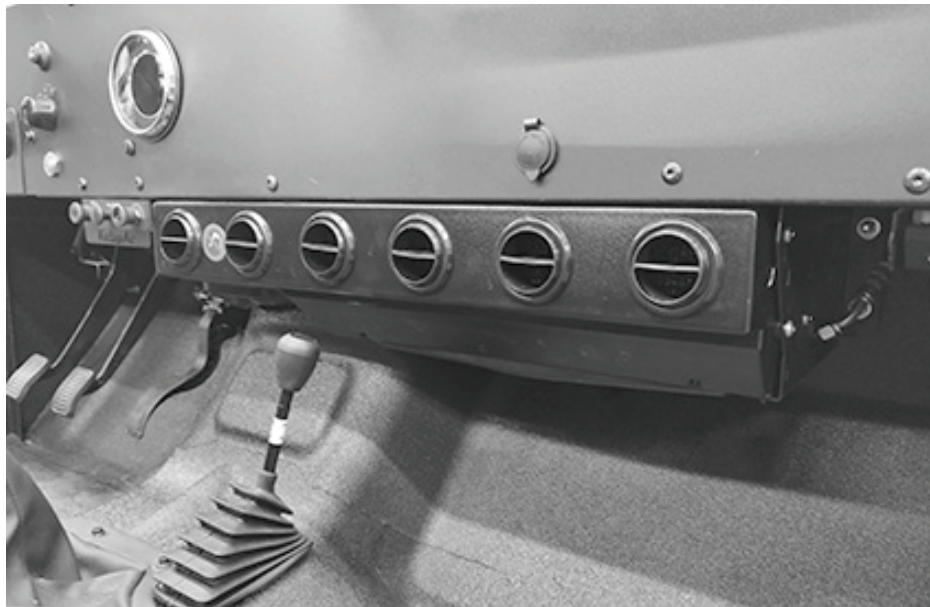

Photo 3



Dash Installed

Photo 4



www.vintageair.com

Final Steps: Completing the Install

1. Reinstall all previously removed items.
2. Fill radiator with at least a 50/50 mixture of approved antifreeze and distilled water. It is the owner's responsibility to keep the freeze protection at the proper level for the climate in which the vehicle is operated. Failure to follow antifreeze recommendations will cause heater core to corrode prematurely and possibly burst in A/C mode and/or freezing weather, voiding your warranty.
3. Double-check all fittings, brackets and belts for tightness.
4. Vintage Air recommends that all A/C systems be serviced by a licensed automotive A/C technician.
5. Evacuate the system for a minimum of 45 minutes prior to charging and perform a leak check prior to servicing.
6. Charge the system to the capacities stated on Page 4 of this instruction manual.
7. See Operation of Controls Procedures on Page 34.



www.vintageair.com

Quality Crimp Guideline

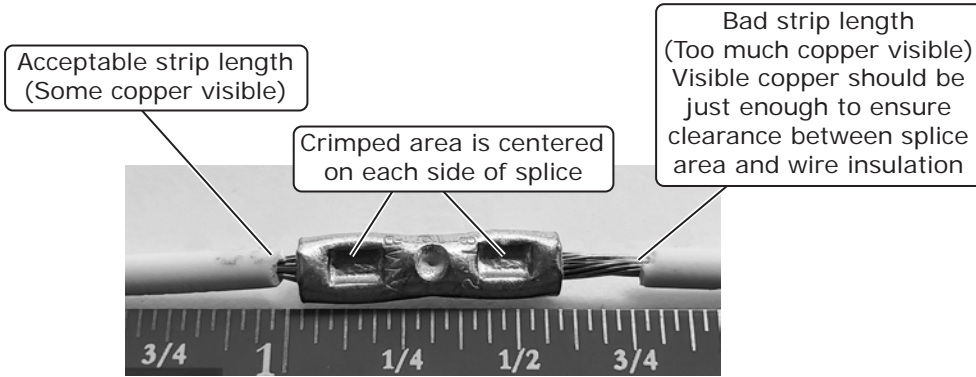

Photo 1

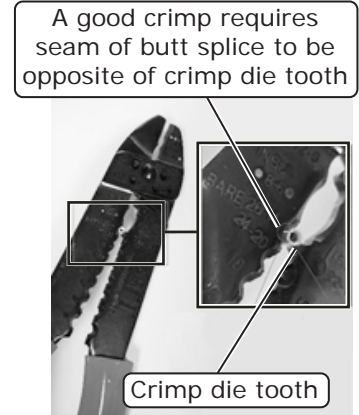

Photo 2

Good Ring Terminal Crimp Bad Ring Terminal Crimp

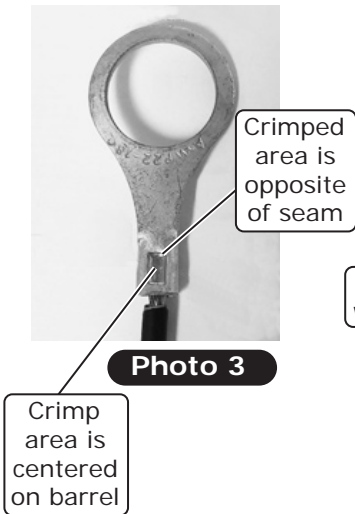

Photo 3

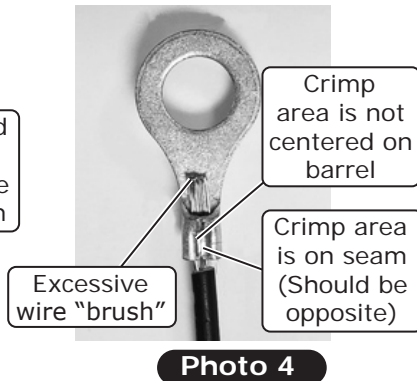

Photo 4

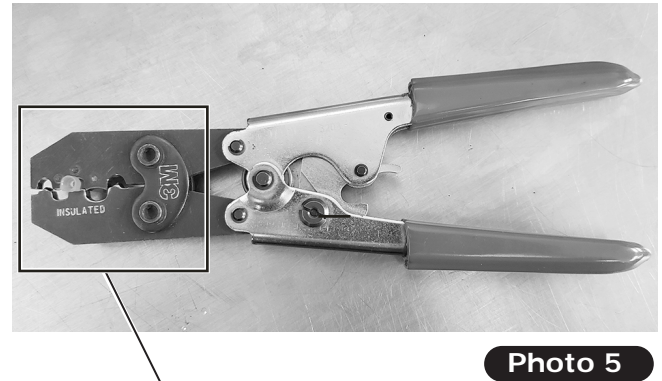

Photo 5

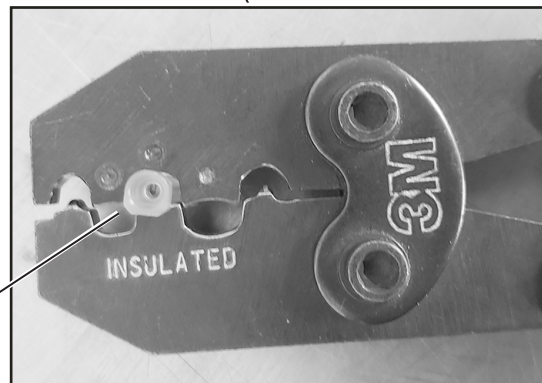

Photo 5a

Use a ratcheting crimp tool for insulated barrel terminals when crimping the provided female insulated terminal. Ensure terminal is inserted in appropriate position before crimping.



www.vintageair.com

Mahindra Wiring Diagram

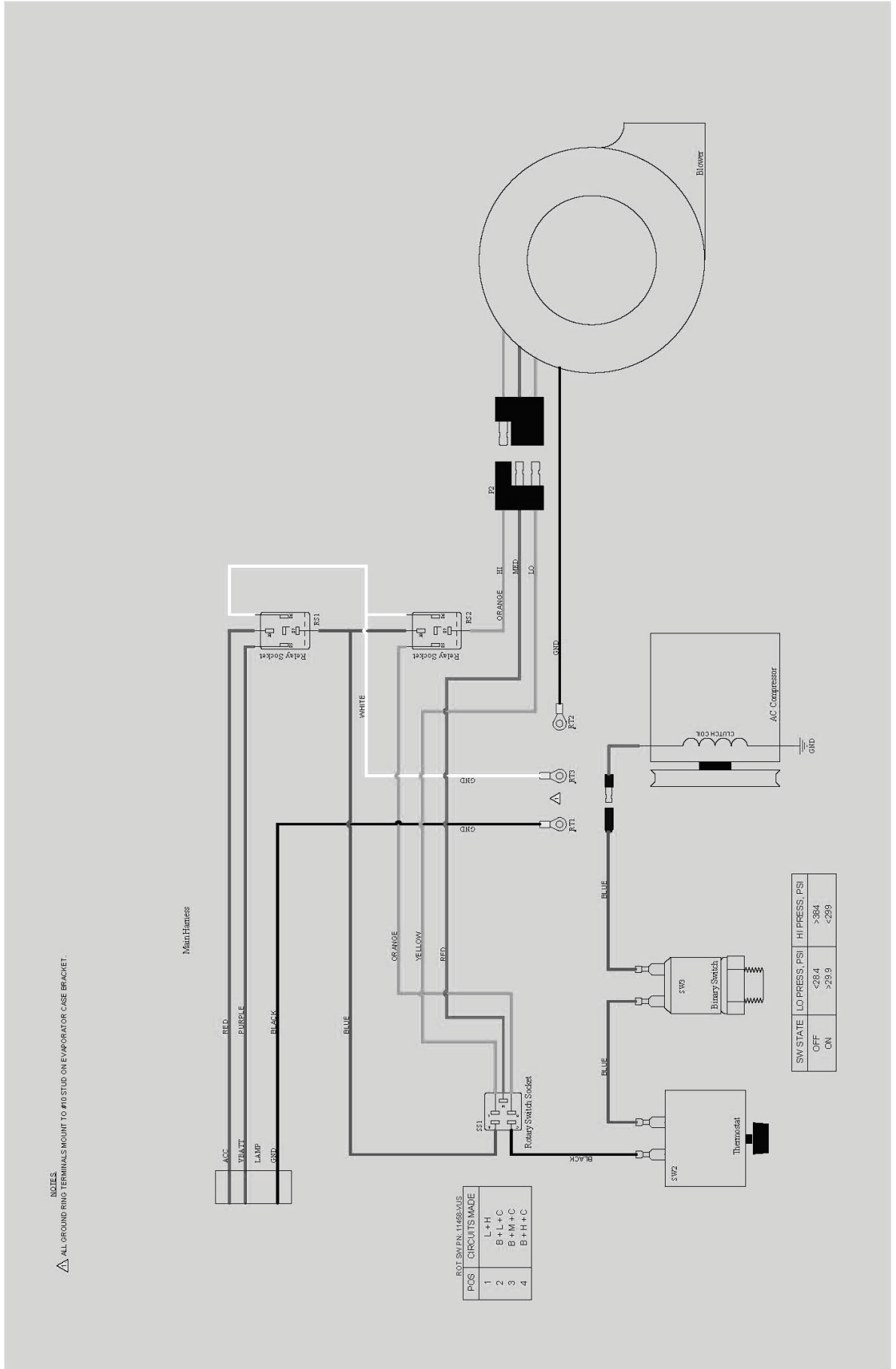

NOTES
 ▲ ALL GROUND RING TERMINALS MOUNT TO #10 STUD ON EVAPORATOR CASE BRACKET.

POS	CIRCUITS MADE
1	L + H
2	B + L + C
3	B + H + C
4	B + H + C

SW STATE	LO PRESS, PSI	HI PRESS, PSI
OFF	<28.4	>38.4
ON	>29.9	<29.9



www.vintageair.com

Operation of Controls

Blower Speed

This lever/knob controls blower speed, from OFF to HI.

Heat Pull

Heat pull knob adjusts flow of hot water through the heater. Pushed in is off. Pull out for increasing heat.

A/C Thermostat

A/C thermostat knob controls the evaporator coil temperature. Counterclockwise is off. Full clockwise is maximum cold (28°).

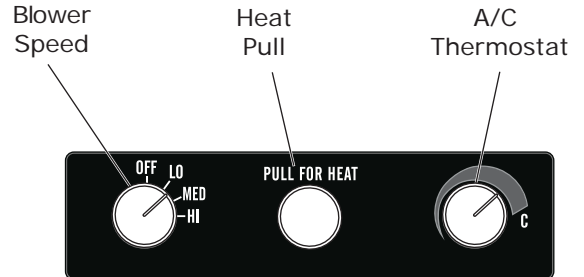

A/C Operation

Blower Speed

Adjust to desired speed.

Heat Pull

Push heat pull knob fully in.

A/C Thermostat

For A/C operation, rotate thermostat clockwise to its stop, then back off slightly (1/8 turn) to prevent coil freeze-up. To warm up vent temperature during A/C operation, slightly increase the heat knob setting or reduce thermostat setting.



NOTE: To avoid windshield fogging in A/C mode, close defrost vents.

Heat Operation

Blower Speed

Adjust to desired speed.

Heat Pull

Pull heat pull knob out to desired temperature.

A/C Thermostat

For maximum heating, rotate thermostat counterclockwise to its stop (off).



NOTE: Close most dash vents and open floor vents.

Defrost/De-fog Operation

Blower Speed

Adjust to desired speed.

Temperature Control

Adjust A/C thermostat to 3/4 cold.

Heat Pull

Pull heat pull knob out to desired temperature.



NOTE: Close dash vents and open defrost vents.



www.vintageair.com

Driver Side Bracket Template (Manual Transmission/ 6-Hole Dash Only)

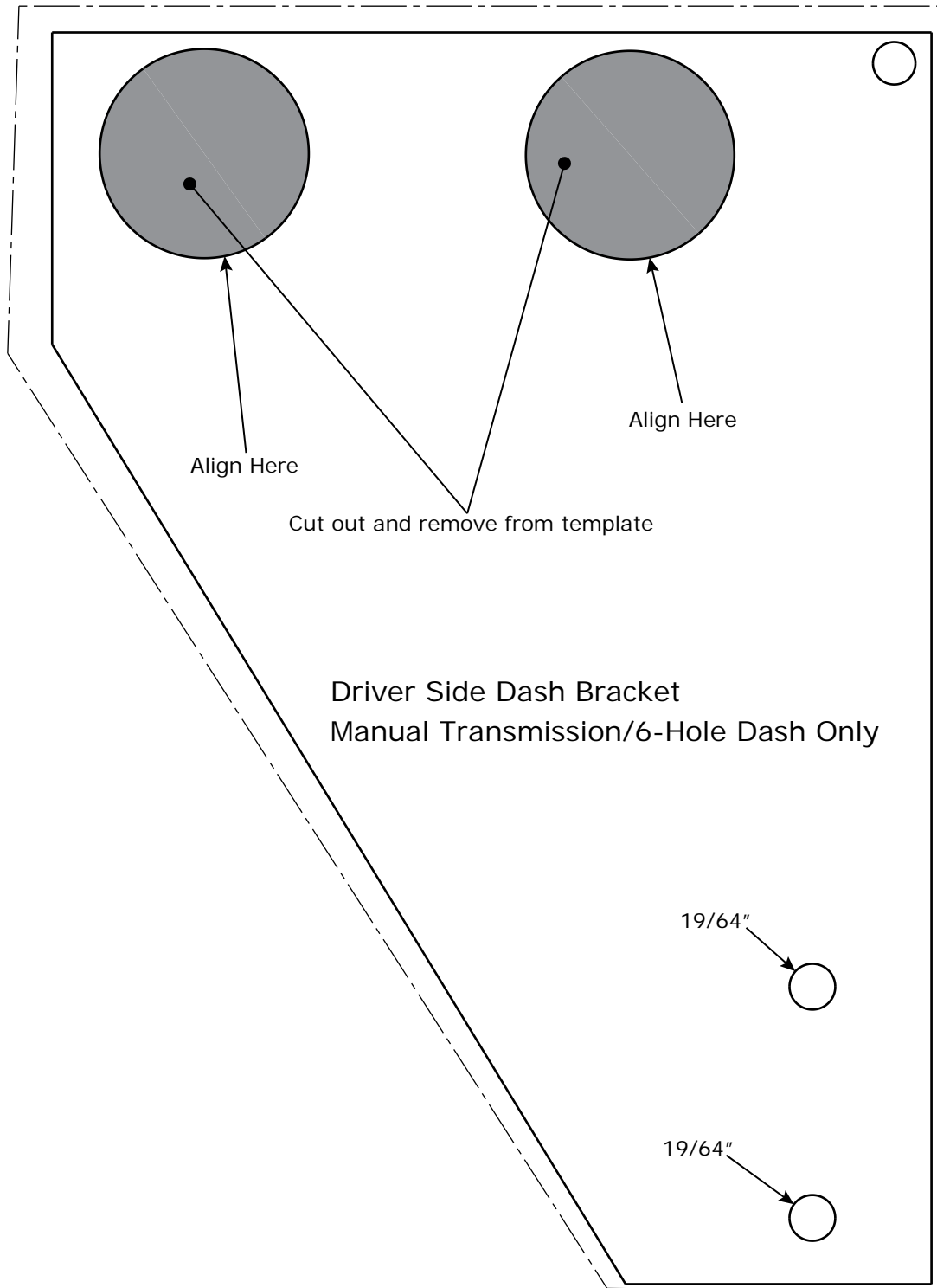

NOTE: Due to printing variances, measure the line below before using this template. If template is scaled properly, the line should measure 6 inches.

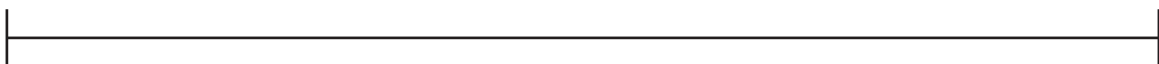



www.vintageair.com

Packing List: Complete Kit (989020)

No.	Qty.	Part No.	Description
1.	1	746014	Mahindra Roxor Slimline Subcase
2.	1	037031	Condenser, 16" x 18", Super Flow
3.	1	046702	Compressor, 6.1 CID 134A V-Groove
4.	1	159020	Bracket Kit, Compressor
5.	1	549020	Hose Kit, Reduced Barrier Standard
6.	1	039020	Condenser Kit
7.	1	631020	Installation Kit
8.	1	280490	Fan Shroud Assembly
9.	5'	06250-VUE	Duct Hose, 2 1/2"

Checked By: _____
 Packed By: _____
 Date: _____

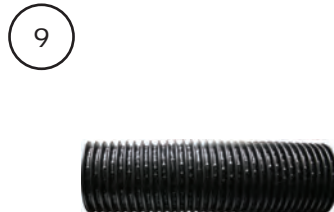
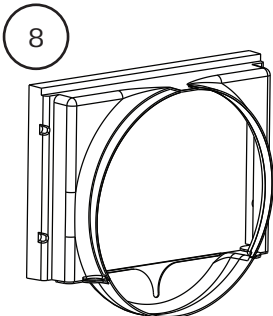
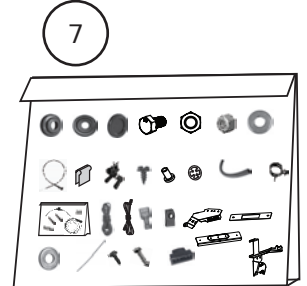
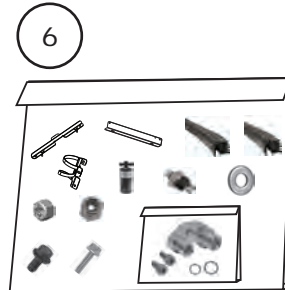
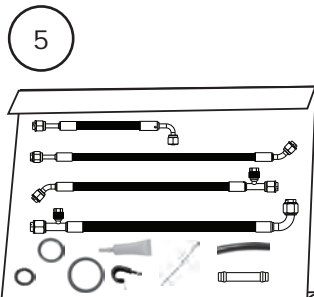
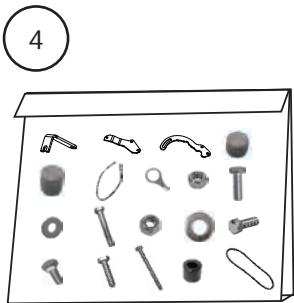
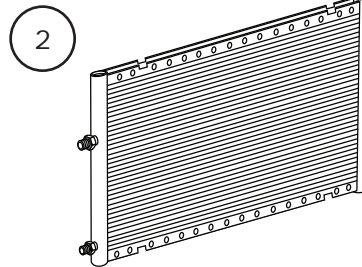
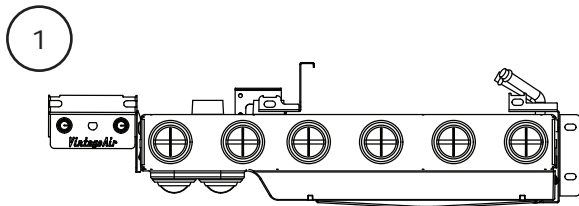

**NOTE: Images may not depict actual parts and quantities.
 Refer to packing list for actual parts and quantities.**



HardCabs,

Mahindra Roxor
Condenser Kit *with* Drier
(039020)



18865 Goll St. San Antonio, TX 78266
Phone: 800-862-6658
Sales: sales@vintageair.com
Tech Support: tech@vintageair.com
www.vintageair.com



www.vintageair.com

Table of Contents

Cover.....	1
Table of Contents.....	2
Packing List/Parts Disclaimer.....	3
Important Notice-Please Read.....	4
Engine Compartment Dissassembly.....	5
Grille Removal, Lubricating O-rings.....	6
Condenser Preparation.....	7
'18-'19 Roxor Core Support Modification.....	8
'18-'19 Roxor Core Support Modification (Cont.).....	9
Condenser Installation.....	10
Drier Installation.....	11
Drier Installation (Cont.).....	12
Packing List.....	13



www.vintageair.com

Packing List: Condenser Kit (039020)

No.	Qty.	Part No.	Description
1.	1	640649	Bracket, Condenser, Bottom
2.	1	640647	Bracket, Condenser, Top
3.	1	200107	Rubber, 15.25", Condenser Bottom
4.	1	200106	Rubber, 10.5", Condenser Top
5.	1	656016	Bracket, Drier
6.	1	07321-VUC	Drier
7.	1	11079-VUS	Binary Switch, Male
8.	5	186011	Washer, .625" O.D. x .281" I.D.
9.	2	186021	Locknut, M6-1.0mm
10.	5	181490	Locknut, 1/4-20
11.	4	182873	Bolt, 1/4-20 x 1/2", Hex
12.	1	188888	Bolt, 1/4-20 x 1", Serrated Flange
13.	1	045003	Compressor Block Kit, 7B10

**** Before beginning installation, open all packages and check contents of shipment. Please report any shortages directly to Vintage Air within 15 days. After 15 days, Vintage Air will not be responsible for missing or damaged items.**

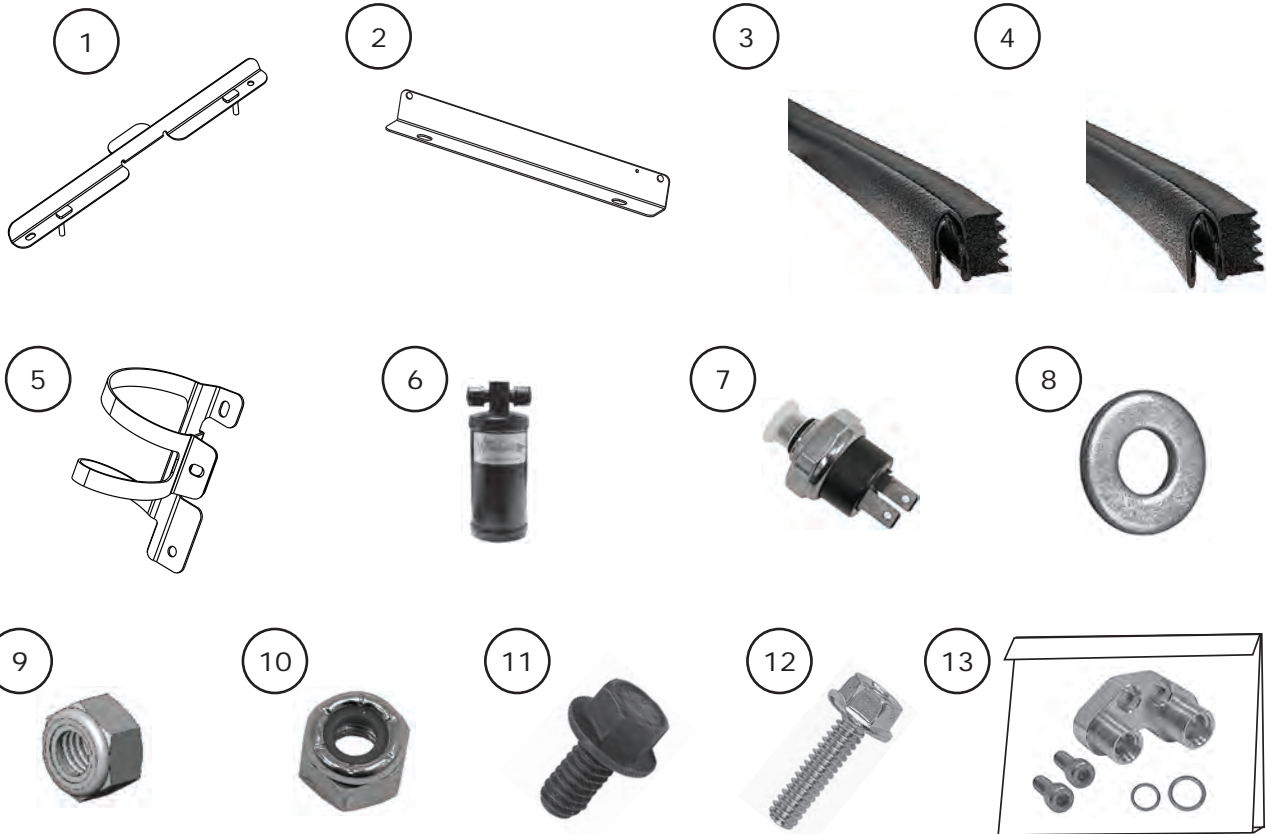

NOTE: Images may not depict actual parts and quantities. Refer to packing list for actual parts and quantities.



www.vintageair.com

Important Notice—Please Read

For Maximum System Performance, Vintage Air Recommends the Following:

NOTE: Vintage Air systems are designed to operate with R134a refrigerant only. Use of any other refrigerant could damage your A/C system and/or vehicle, and possibly cause a fire, in addition to potentially voiding the warranties of the A/C system and its components.

Refrigerant Capacities:

Vintage Air System: 1.7 lbs. (27.2 oz.) or 771 grams of **R134a**, charged by weight with a quality charging station or scale. **NOTE: Use of the proper type and amount of refrigerant is critical to system operation and performance.**

Other Systems: Consult manufacturer's guidelines.

Lubricant Capacities:

New Vintage Air-Supplied Sanden Compressor: No additional oil needed (Compressor is shipped with proper oil charge).

All Other Compressors: Consult manufacturer (Some compressors are shipped dry and will need oil added).

Safety Switches

Your Vintage Air system is equipped with a binary pressure safety switch. A binary switch disengages the compressor clutch in cases of extreme low pressure conditions (refrigerant loss) or excessively high head pressure (406 PSI) to prevent compressor damage or hose rupture. A trinary switch combines Hi/Lo pressure protection with an electric fan operation signal at 254 PSI, and should be substituted for use with electric fans. Compressor safety switches are extremely important since an A/C system relies on refrigerant to circulate lubricant.

Service Info:

Protect Your Investment: Prior to assembly, it is critical that the compressor, evaporator, A/C hoses and fittings, hardlines, condenser and receiver/drier remain capped. Removing caps prior to assembly will allow moisture, insects and debris into the components, possibly leading to reduced performance and/or premature failure of your A/C system. This is especially important with the receiver/drier.

Additionally, when caps are removed for assembly, **BE CAREFUL!** Some components are shipped under pressure with dry nitrogen.

Evacuate the System for 35-45 Minutes: Ensure that system components (Drier, compressor, evaporator and condenser) are at a temperature of at least 85°F. On a cool day, the components can be heated with a heat gun **or** by running the engine with the heater on before evacuating. Leak check and charge to specifications.

Bolts Passing Through Cowl and/or Firewall:

To ensure a watertight seal between the passenger compartment and the vehicle exterior, for all bolts passing through the cowl and/or firewall, Vintage Air recommends coating the threads with silicone prior to installation.

Heater Hose (not included with this kit):

Heater hose may be purchased from Vintage Air (Part#31800-VUD) or your local parts retailer. Routing and required length will vary based on installer preference.



www.vintageair.com

Engine Compartment Disassembly

NOTE: Before starting the installation, check the function of the vehicle (horn, lights, etc.) for proper operation, and study the instructions, illustrations, & diagrams.

Perform the following:

1. Disconnect the battery.
2. Drain the coolant through the petcock valve on the bottom of the radiator (See Photo 1, below).
3. Remove the air box clamp, spring clamp, crank case vent hose, and turbo inlet clamp (See Photos 2, 3 and 4, below).
4. Remove the entire air box assembly (See Photo 5, below).

Drain coolant through
petcock valve on bottom
of radiator



Photo 1

Remove air
box clamp

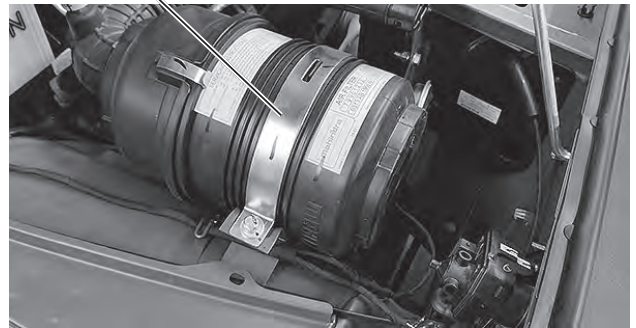

Photo 2

Remove turbo
inlet clamp

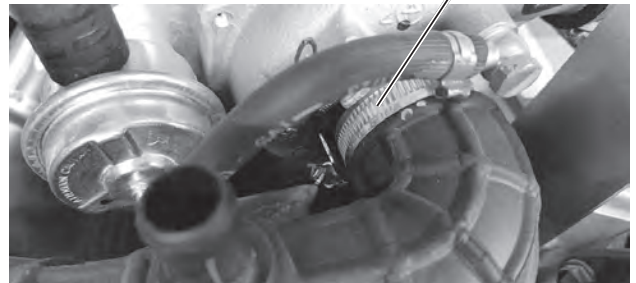

Photo 4

Remove spring
clamp and crank
case vent hose



Photo 3

Remove entire
air box assembly

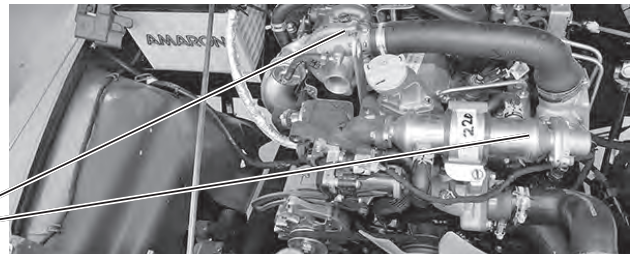

Photo 5



www.vintageair.com

Grille Removal

1. Remove the grille by removing (18) clips from the core support as shown in Photo 1, below.
2. Remove (1) T-30 screw from the bottom center (See Photo 2, below).
3. Clips and holes visible with grille removed (See Photos 3 and 4, below).

Remove grille by removing (18) clips from core support

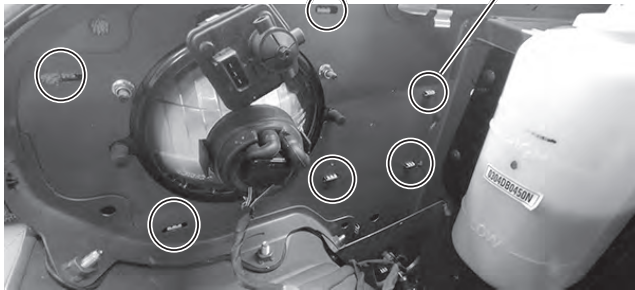

Photo 1

Remove (1) T-30 screw from bottom center



Photo 2

Clips and holes visible with grille removed

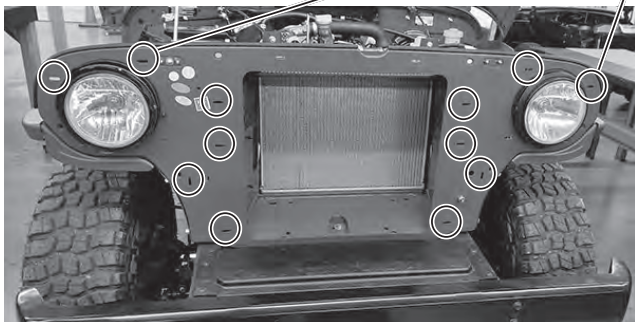

Photo 3

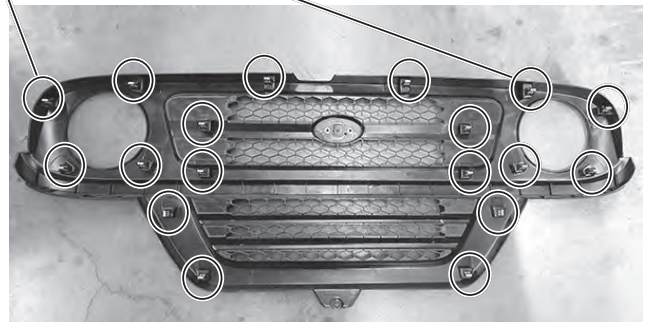
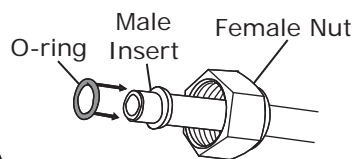
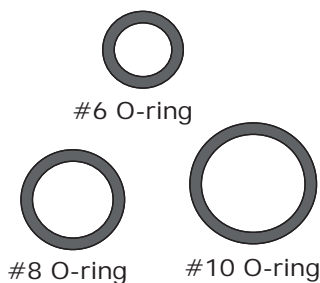

Photo 4

Lubricating O-rings

For a proper seal of fittings: Install supplied O-rings as shown and lubricate with refrigerant oil.



Refrigerant Oil for O-rings

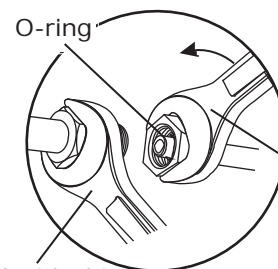
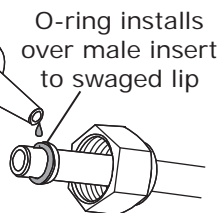

Twist with this wrench

Hold with this wrench

NOTE: Standard torque specifications:
 #6: 11 to 13 ft-lb.
 #8: 15 to 20 ft-lb.
 #10: 21 to 27 ft-lb.



www.vintageair.com

Condenser Preparation

1. On a bench, lay the condenser flat with the larger #8 port at the top left (See Photo 1, below).
2. Install the longer insulator into the bottom channel of the condenser, with the groove at front, aligned to the left side (See Photos 2 and 3, below).
3. Install the bottom condenser bracket with studs into the groove on the insulator. Align to the left (See Photo 4, below).
4. Mark the top rail of the condenser 1" from the left side on the channel (See Photo 5, below).
5. Install the shorter insulator aligned with the mark, with the groove facing the back of the condenser (See Photo 6, below).
6. Install the top condenser bracket into the insulator groove with the slotted holes towards the front of the condenser (See Photo 7, below).

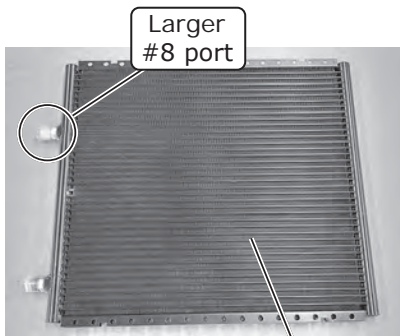

Photo 1

Lay condenser flat on a bench

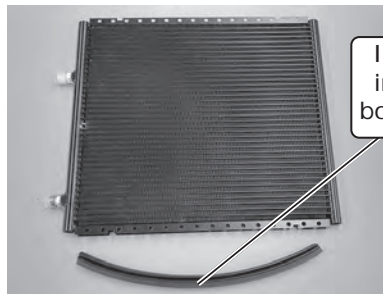

Photo 2

Mark top rail of condenser 1" from left side on channel



Photo 3

Install short insulator aligned with mark, with groove facing back of condenser

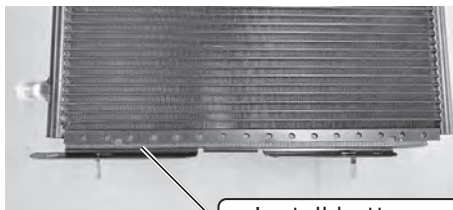

Photo 4

Install bottom condenser bracket with studs into groove on insulator

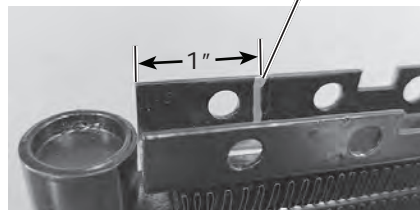

Photo 5



Photo 6

Install top condenser bracket into insulator groove with slotted holes towards front of condenser



Photo 7



www.vintageair.com

'18-'19 Roxor Core Support Modification

NOTE: If installing the condenser on earlier non-air equipped vehicles, the following holes may need to be drilled in the core support/radiator box.

1. On the bottom inside of the core support, mark and drill (2) 5/16" holes using the following dimensions (See Photos 1 and 2, below).
2. On the inner passenger side of the core support, mark and drill a 1/4" lower hole, and a 1 3/8" upper hole using the measurements below (See Photo 3 and 4, below).
3. On the top of the core support, mark and drill (2) 5/16" holes using the measurements below (See Photos 5 and 6, below).

On the bottom inside of the core support, mark and drill (2) 5/16" holes

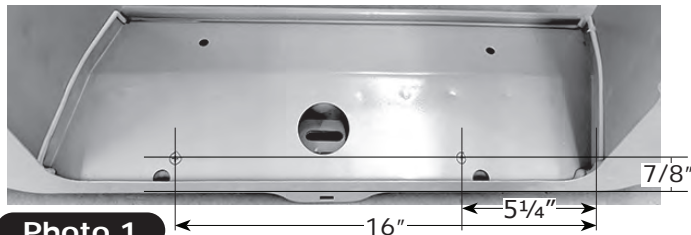

Photo 1



Photo 2

On the inner passenger side of the core support, mark and drill a 1/4" lower hole, and a 1 3/8" upper hole

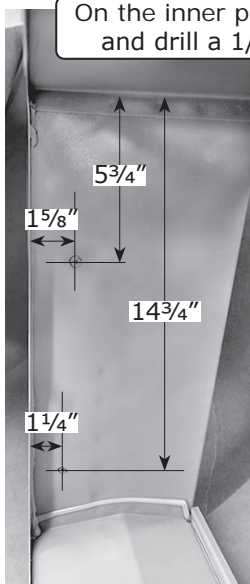

Photo 3

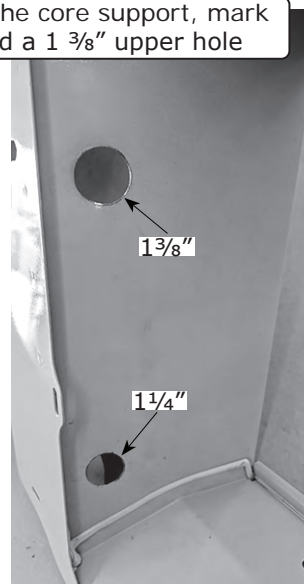

Photo 4

On the top of the core support, mark and drill (2) 5/16" holes

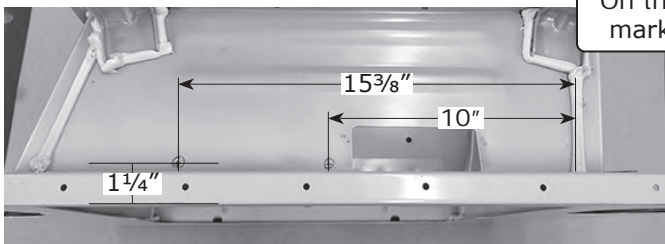

Photo 5

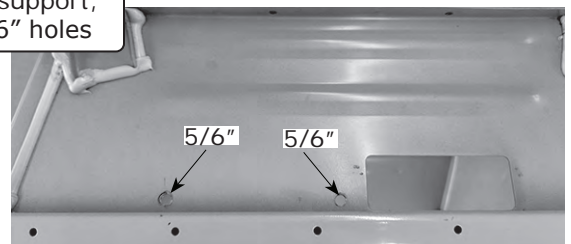

Photo 6



www.vintageair.com

'18-'19 Roxor Core Support Modification (Cont.)

4. Mark holes on passenger-side core support brace using the measurements shown in Photo 7, below.
5. Verify that the drier bracket will align with the holes, then drill both to $5/16''$ (See Photo 8, below).

Mark holes on the passenger-side of core support brace

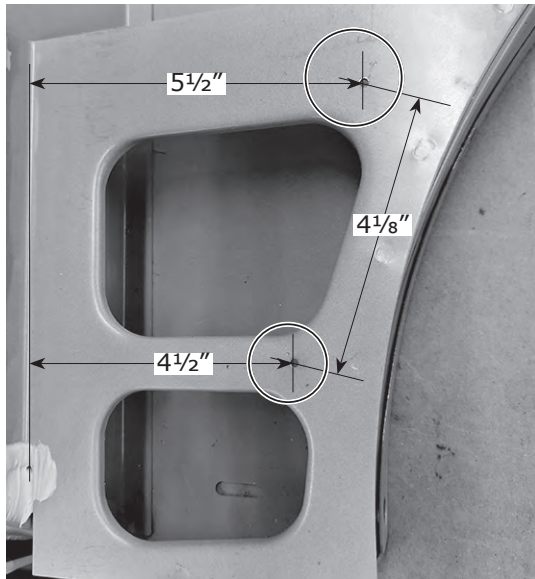

Photo 7

Align the drier bracket with the holes and drill (2) $5/16''$ holes



Photo 8



www.vintageair.com

Condenser Installation

1. Install the condenser assembly into the core support, aligning the bottom studs into the lower mounting holes as shown in Photos 1 and 2, below.
2. Push the top condenser bracket into place, securing it with (2) 1/4-20 x 1/2" hex bolts, and (2) 1/4-20 locknuts (See Photos 4 and 5, below). **NOTE: For '18-'19 Roxors, install the bracket into previously drilled holes as shown in Photo 3, below.**
3. Secure the bottom condenser bracket studs with (2) .625" O.D. x .281" I.D. washers, and (2) M6-1.0mm locknuts (See Photos 6 and 7, below).

Install condenser assembly into core support, aligning bottom studs into lower mounting holes

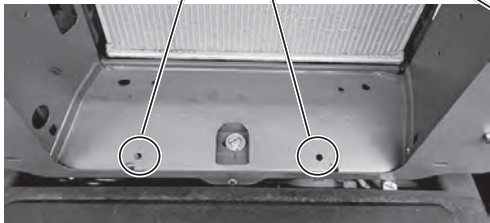

Photo 1

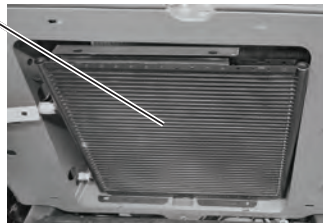

Photo 2

For '18-'19 Roxor, install bracket into previously drilled holes

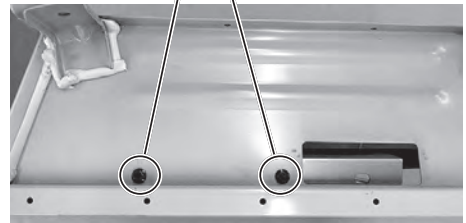

Photo 3

Push upper bracket into place, secure with (2) 1/4-20 x 1/2" hex bolts, and (2) 1/4-20 locknuts

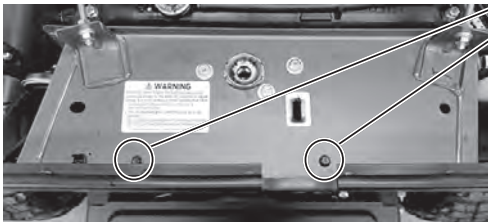

Photo 4

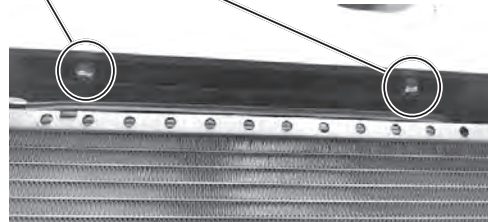

Photo 5

Secure lower bracket studs with (2) .625" O.D. x .281" I.D. washers, and (2) M6-1.0mm locknuts

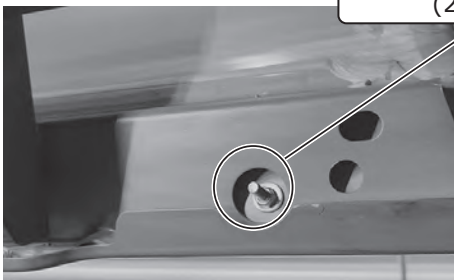

Photo 6

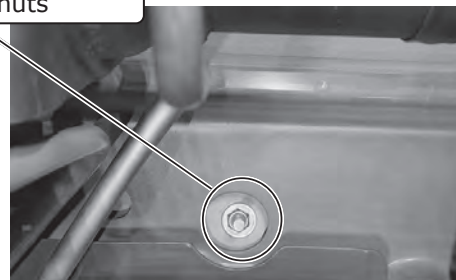

Photo 7



www.vintageair.com

Drier Installation

1. Locate the mounting holes on the passenger-side core support brace (See Photo 1, below).
2. Secure the drier bracket using (2) 1/4-20 x 1/2" hex bolts, and (2) 1/4-20 locknuts (See Photo 2, below).
3. For '18-'19 Roxors, install the drier bracket into previously drilled holes as shown on Photo 3, below.
4. On a bench, remove the drier plug, and with properly lubricated O-ring, install the male binary switch as shown in Photos 4 and 5, below. **NOTE: The binary switch and the drier each come with an O-ring. Only one of the (2) O-rings will be used.**
5. Identify the #6 A/C hose with 90° and straight fittings. With a properly lubricated O-ring, install the hose inlet side of the drier as shown in Photo 6, below.

Locate mounting holes on passenger-side core support brace



Photo 1

Secure drier bracket using (2) 1/4-20 x 1/2" hex bolts, and (2) 1/4-20 locknuts



Photo 2

For '18-'19 Roxors, install the drier bracket into previously drilled holes



Photo 3



Photo 4

Remove drier plug, and with properly lubricated O-ring, install male binary switch



Photo 5

Install #6 A/C hose inlet side of drier with a properly lubricated O-ring



Photo 6



www.vintageair.com

Drier Installation (Cont.)

6. Install the drier into the drier bracket as shown in Photo 7, below. **NOTE: Refrigerant flow through drier is IN from condenser, OUT to evaporator.**
7. With a properly lubricated O-ring, install the hose end with a straight fitting onto the lower condenser port (See Photo 7, below)
8. Secure the drier bracket clamp with a 1/4-20 x 1" hex bolt, a .625" O.D. x .281" I.D. washer, and a 1/4-20 locknut (See Photo 8, below). Leave loose for later adjustment.

Install drier into drier bracket

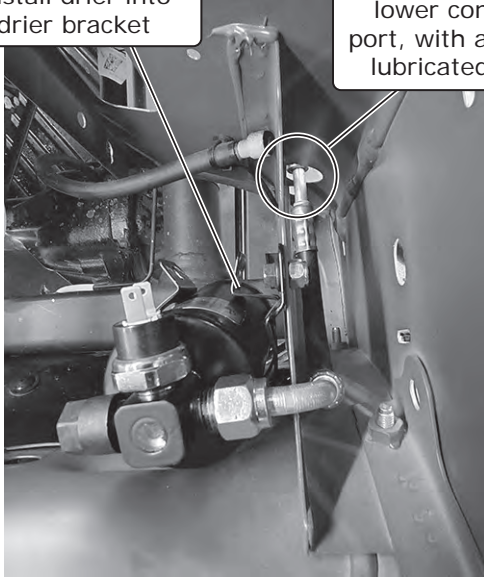

Photo 7

Install hose end with straight fitting onto lower condenser port, with a properly lubricated O-ring

Secure drier bracket clamp with a 1/4-20 x 1" hex bolt, a .625" O.D. x .281" I.D. washer, and a 1/4-20 locknut

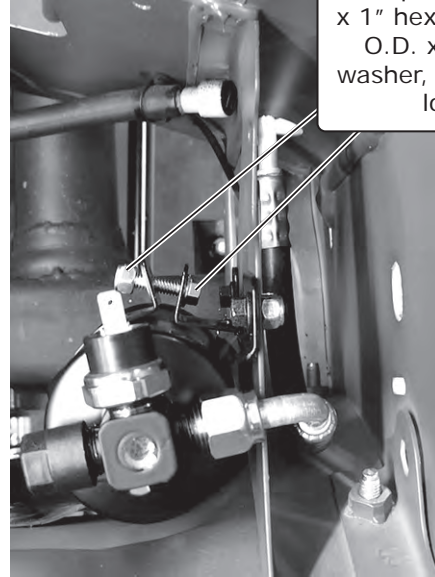

Photo 8

NOTE: Do not remove the caps from the drier. The drier contains a desiccant that will quickly absorb moisture from the air, causing it to lose effectiveness. For this reason, Vintage Air recommends that the drier remains capped until the installer is ready to evacuate the system.



www.vintageair.com

Packing List: Condenser Kit (039020)

No.	Qty.	Part No.	Description
1.	1	640649	Bracket, Condenser, Bottom
2.	1	640647	Bracket, Condenser, Top
3.	1	200107	Rubber, 15.25", Condenser Bottom
4.	1	200106	Rubber, 10.5", Condenser Top
5.	1	656016	Bracket, Drier
6.	1	07321-VUC	Drier
7.	1	11079-VUS	Binary Switch, Male
8.	5	186011	Washer, .625" O.D. x .281" I.D.
9.	2	186021	Locknut, M6-1.0mm
10.	5	181490	Locknut, 1/4-20
11.	4	182873	Bolt, 1/4-20 x 1/2", Hex
12.	1	188888	Bolt, 1/4-20 x 1", Serrated Flange
13.	1	045003	Compressor Block Kit, 7B10

Checked By: _____
Packed By: _____
Date: _____

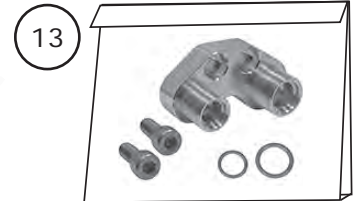
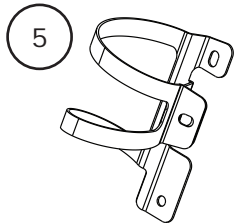
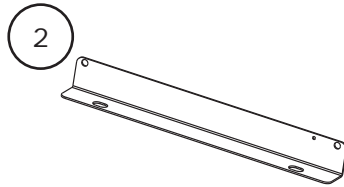
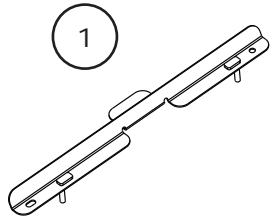

**NOTE: Images may not depict actual parts and quantities.
Refer to packing list for actual parts and quantities.**