



INSTALLATION INSTRUCTIONS

POLARIS
RNG 570 EFI KPC
MIDSIZE

HardCabs →



SAFETY INSTRUCTIONS

Warning: Failure to heed all safety and operating instructions and warnings regarding use of this product can result in serious bodily injury.

READ PROPERLY COMPLETE ASSEMBLY INSTRUCTIONS BEFORE STARTING OF ASSEMBLY

Install all parts indicated in assembly instructions. Failure to fully assemble product before use could result in personal injury.

Assembly of product requires use of hand or power tools. If you are not experienced in using these types of tools, have product dealer do the install for you.

Some parts contain sharp edges, wear protective gloves if necessary.

Always keep your assembly area clean, uncluttered and well lit.

Keep visitors and children a safe distance away from the assembly area. Visitors should wear the same safety equipment described under.

Never operate your UTV with the cab doors open. Failure to properly latch the doors before moving the vehicle could result in serious injury.

Dress for safety. DO NOT wear loose clothing, gloves, neckties or jewelry if using power tools to assemble this product.

Insert all nut covers after you finish installation.

Never drive your UTV with the cab front window in open position. Failure of improperly latching/locking front window before driving the vehicle could result in serious injury.

Please be careful not to break the plastic washers, if you're tightening screws with plastic washers use max torque of 3.7 foot-pound force (5 Nm)!!!

MAINTENANCE AND CLEANING

To clean polycarbonate surface use soapy water solution or other subtle means.

Dirt and dust wash by gently water stream and swipe only with wet or damp means in the direction from top to bottom.

The recommended frequency of cleaning of polycarbonate part is about 1 time per month or according to the actual degree of pollution.

***Do not use detergents that could scratch the surface plates.
(abrasives, harsh fabrics, etc.)***

***Do not use solvents or alkaline detergents or cleaners with ammonia
(ammonium hydroxide).***

Do not remove the impurities from the surface of the razor blades or other sharp items.

Do not clean cabin when the polycarbonate plates are heated by the sun.

Do not use the squeegee, it could be scratched surface plates.

Do not clean the water current strength greater than 50 bar (WAP)

The manufacturer is not responsible for scratching the surface in case of failure to comply with the above instructions.

All bolted connections of cab must be by user at regular intervals checked and tightened.

PREPARATION FOR INSTALLATION:

Uninstall all additional systems from the roller cages (work lights, rear mirrors, drink holders etc.)

CAB PREVIEW

4

ELECTROINSTALLATION-WIPER+WASHER step 1.

Parts needed

Included

Washer tube



Switch wiper/washer/off



Harness and washer tank



Wiper harness



Install the washer tank holder onto the front UTV roller cage ledge.



6

Connect the harness branch No.: 3 with washer motor and slide the washer tank onto the washer tank holder. Lead harness from the washer to the inner place in the dashboard.



FOR ALL TECHNICAL QUESTIONS, PLEASE CALL
DFK AMERICA INC.
(630) 324-8585

Lead the harness branch No.: 1 (red arrow) to the right front roller cage.

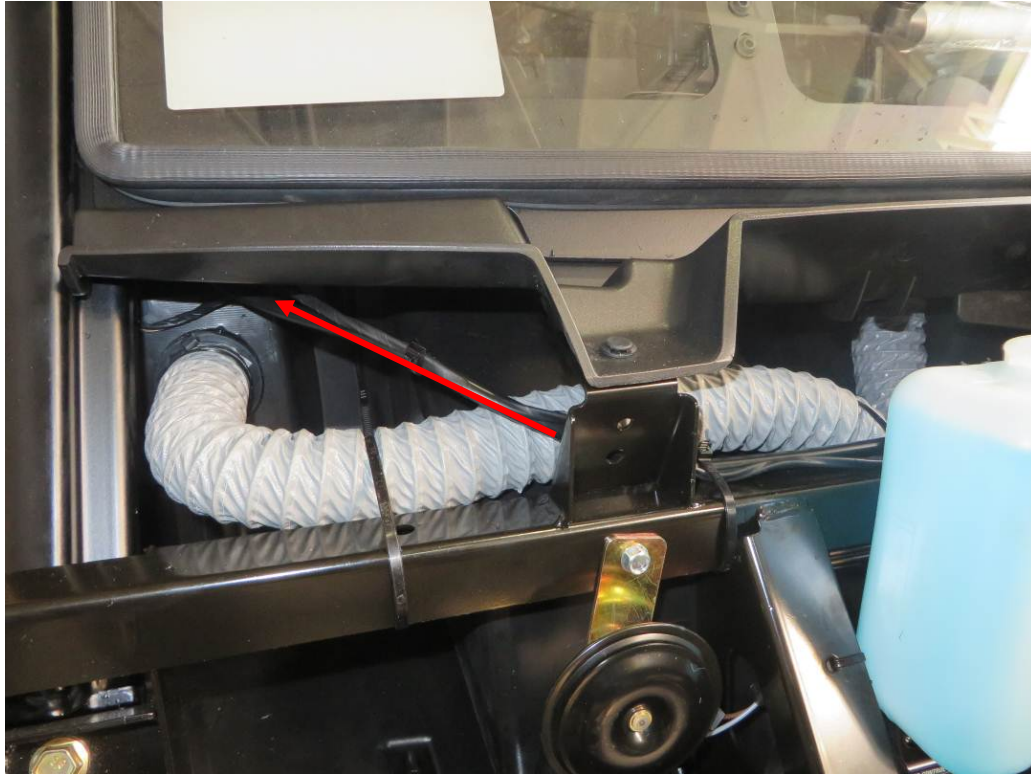

Drill hole (red circle) \varnothing 21mm (0,83in) into the dashboard cover near the right roller cage and stretch the harness branch through the hole.



FOR ALL TECHNICAL QUESTIONS, PLEASE CALL
DFK AMERICA INC.
(630) 324-8585

Carefully cut the hole 44,9x21,7mm (red rectangle). Pull the harness branch No.: 2 throught the hole and connect the harness with the switch wiper/washer.



Detail view of connections.

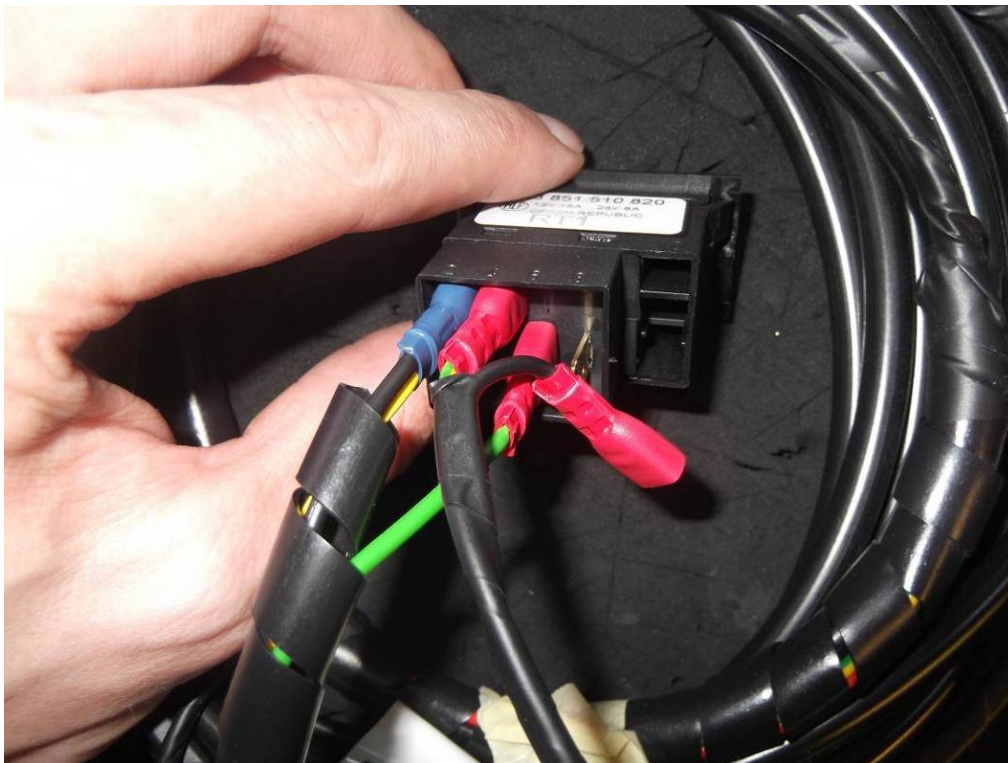





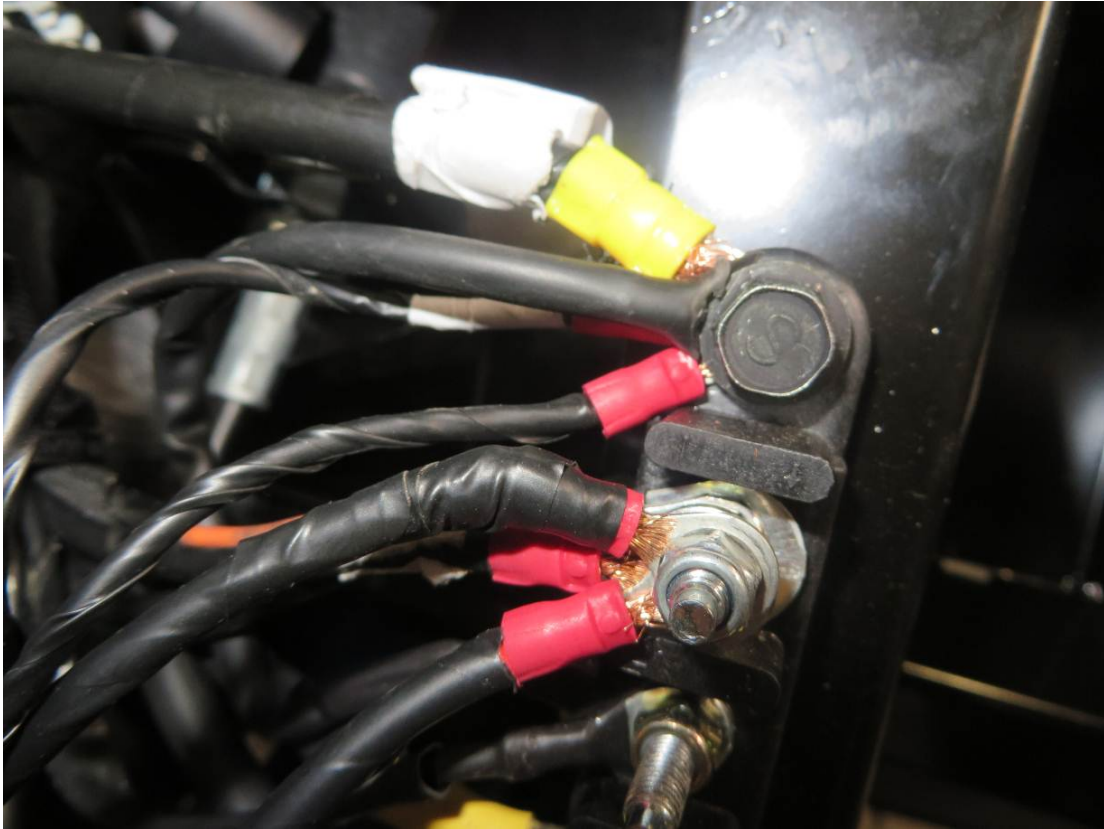

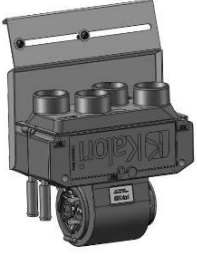

FOR ALL TECHNICAL QUESTIONS, PLEASE CALL
DFK AMERICA INC.
(630) 324-8585

Connect the wiper/washer harness to the original electroinstalation.

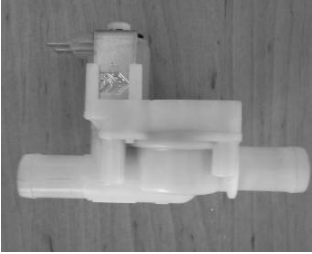

Fill the washer liquide to the washer tank before first usage.

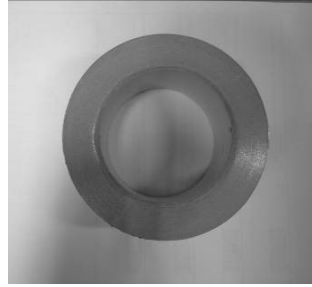
ELECTROINSTALLATION – HEATER
Parts needed (included)

		
<p>Heater with cover</p>	<p>Bleeding valve</p>	<p>Electric vent</p>
		
<p>Tightening straps Smaller, bigger and large</p>	<p>Air vent smaller</p>	<p>Air vent bigger</p>
		
<p>Hot air hose</p>	<p>AL tape</p>	<p>Y coupling</p>

<p>Y coupling</p>	<p>El. Vent switch</p>	<p>Heater switch assembly</p>
<p>Heater harness</p>	<p>Hot water hose</p>	

IMPORTANT

IT IS ABSOLUTELY NECESSARY TO TAKE OUT THE RUBBER PLUGS FROM THE HEATER TUBES!!!

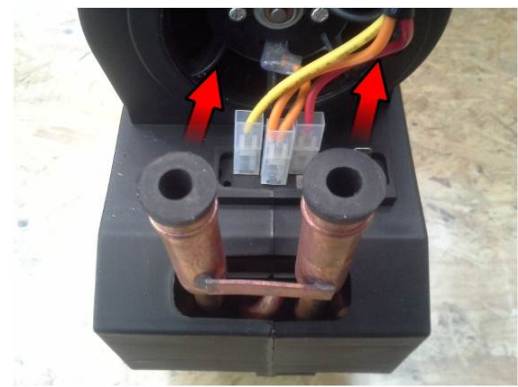
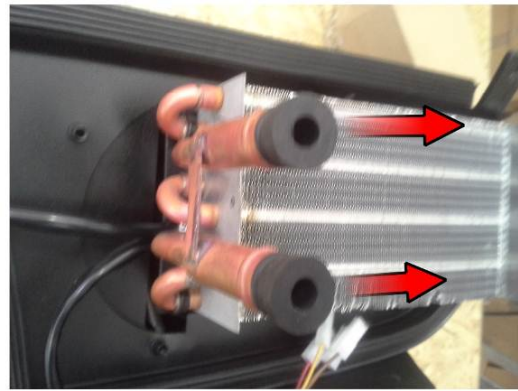

Uninstall the central tunnel cover from UTV's floor.



Install the heater onto the heater holder and install heater assembly into the front boot space.

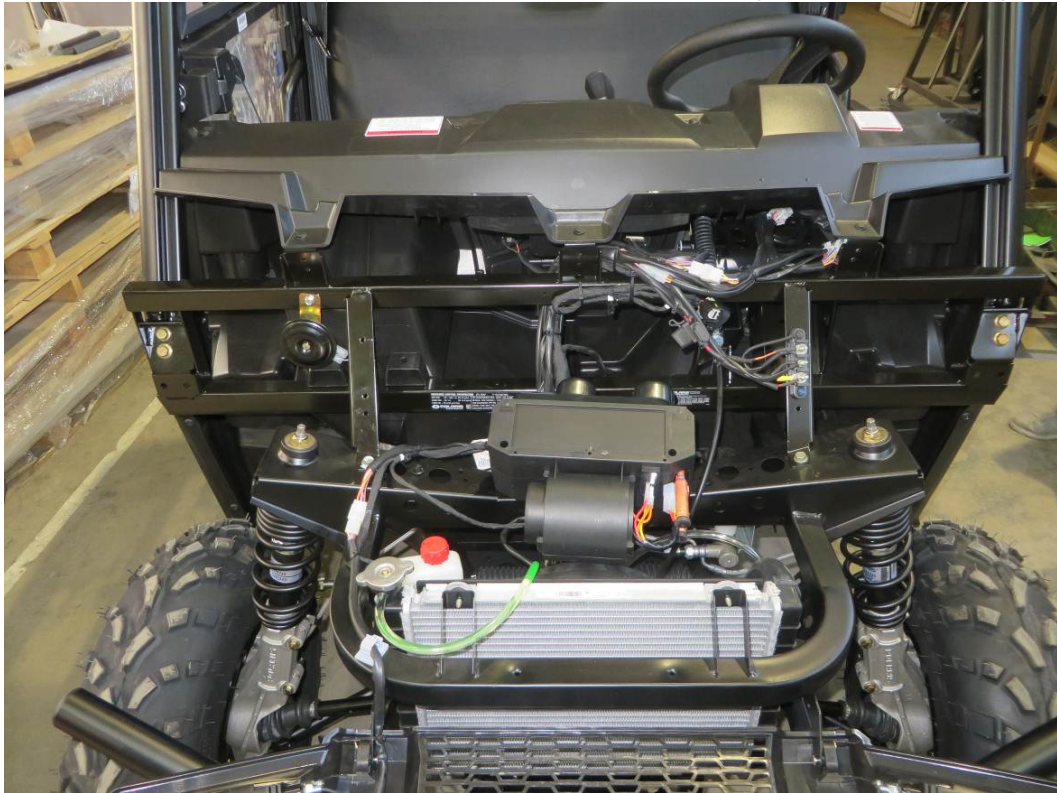

FOR ALL TECHNICAL QUESTIONS, PLEASE CALL
DFK AMERICA INC.
(630) 324-8585

Secure original hot water hose (with red line) by pliers or clamps.



Cut the hose between pliers and insert tightening straps at loose ends. Install the small "Y" coupling into the original hose and into the heater hose (included). Tighten all (3) straps hard and lead the water hose from the engine to the central floor tunnel. It is necessary to keep the heater hose (red arrow) in direction of down and forward. **Side view.**



FOR ALL TECHNICAL QUESTIONS, PLEASE CALL
DFK AMERICA INC.
(630) 324-8585

Lead the water hoses (red arrow) through the floor tunnel.



Cut the water hose (with red line) to correct length, be careful to not cut that hose too short.

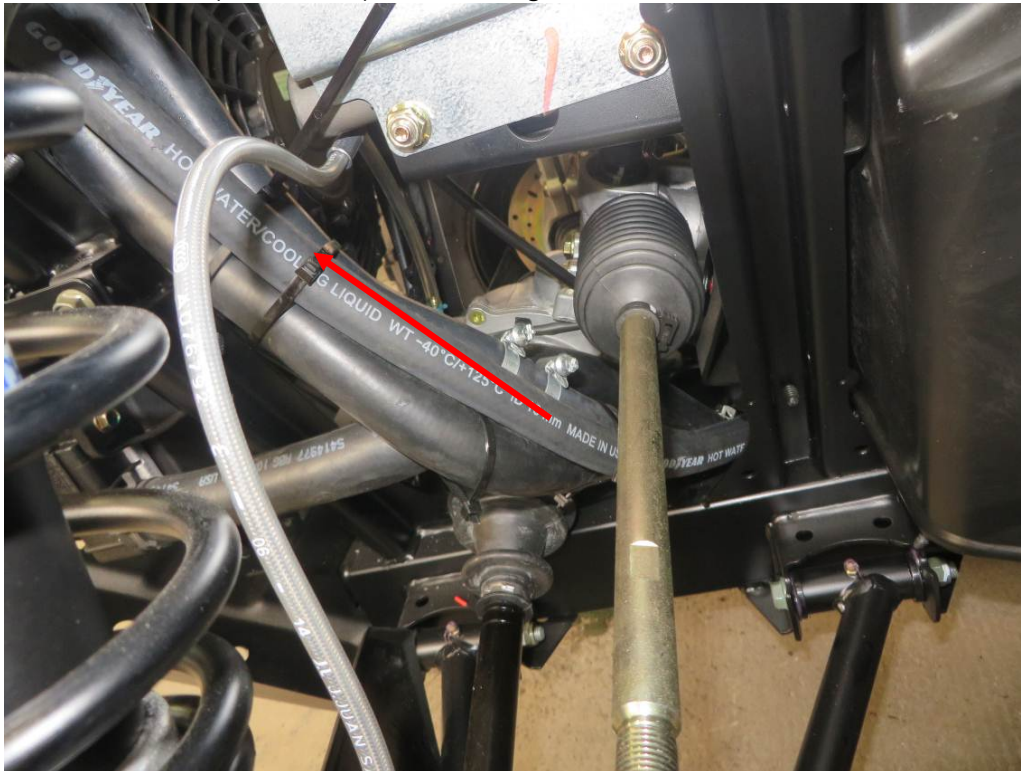

FOR ALL TECHNICAL QUESTIONS, PLEASE CALL
DFK AMERICA INC.
(630) 324-8585

Install the bended hoses onto the heater tubes. Fix these hoses with the heater tubes by tightening straps and tighten these straps very hard. Insert the tightening strap onto the bended hose and install electromagnetic valve in same orientation like in picture. Tighten that strap very hard.

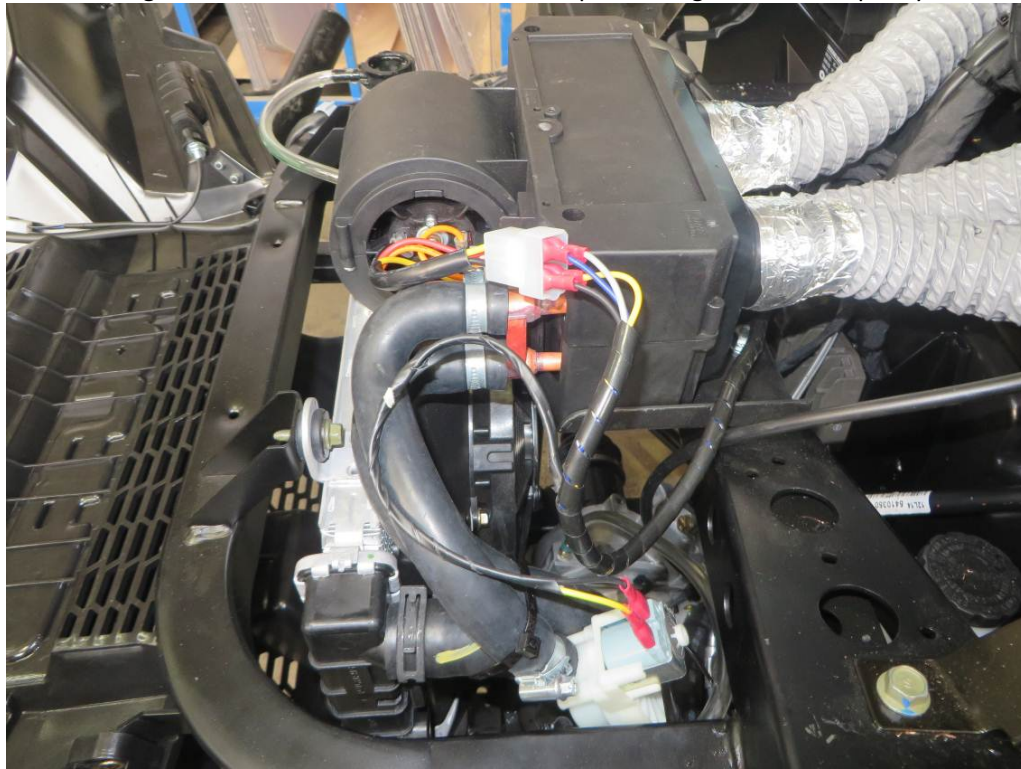

Connect harness branch No.: 3 with the heater connector. Detail view.

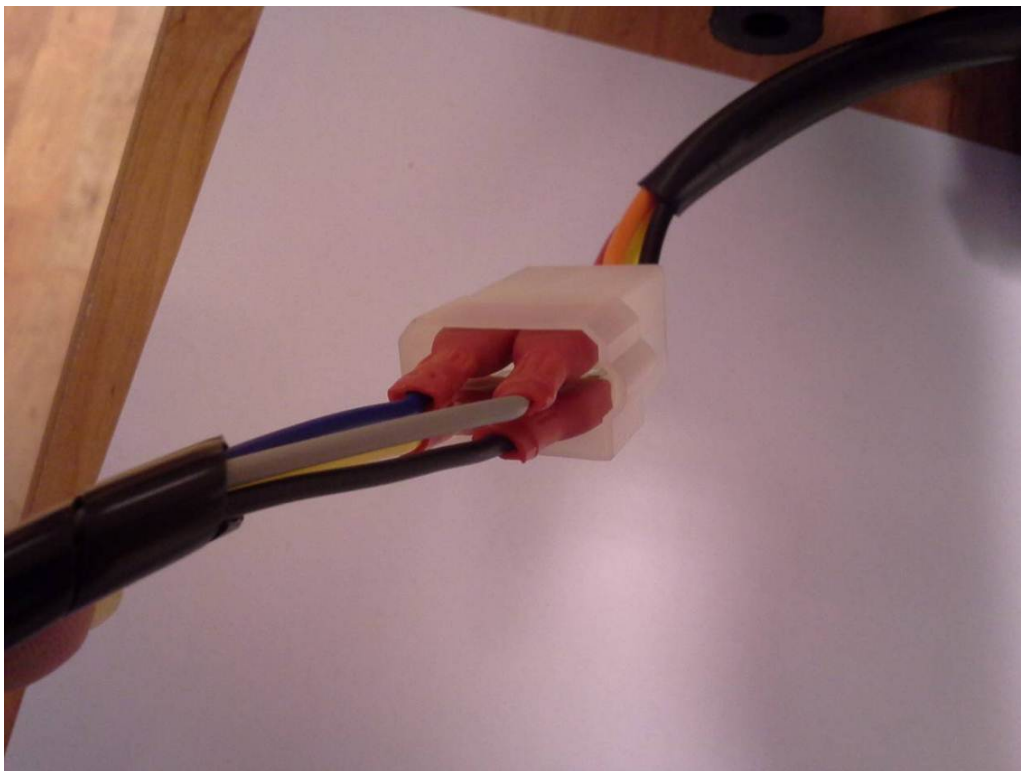

Connect the harness branch No.: 4 with the electromagnetic vent. Detail view.

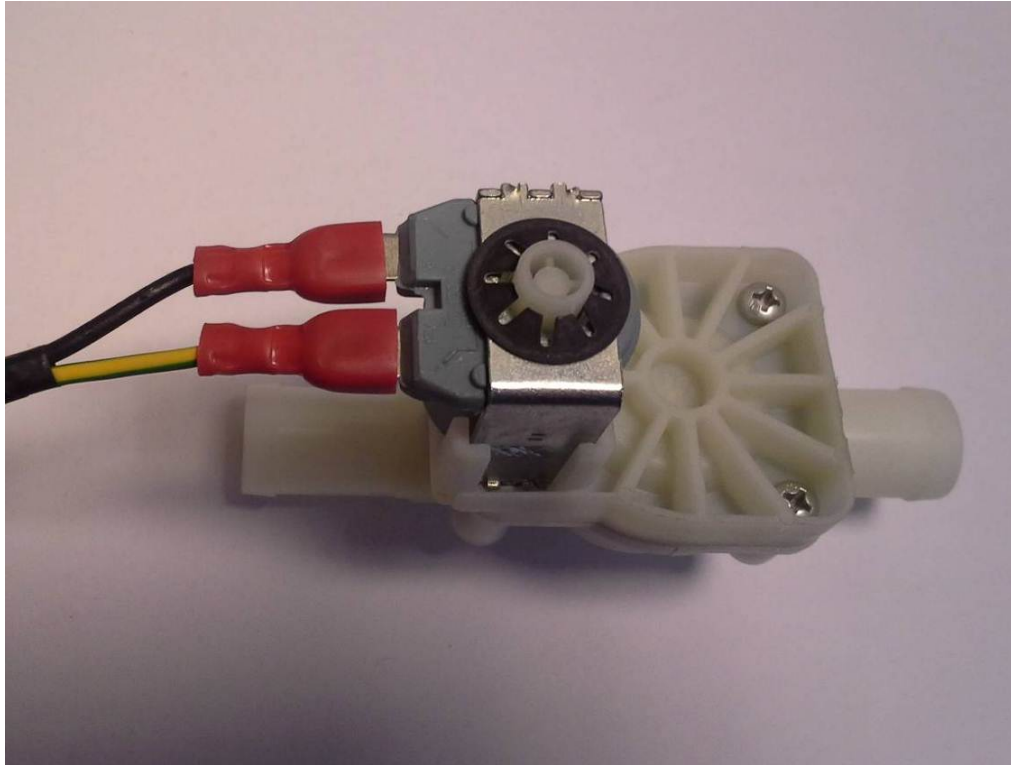

SEE NEXT PAGES

17

Insert the tightening strap onto the hose from engine (red arrow) and connect that hose with electromagnetic valve. Tighten strap very hard. Connect the water hose (violet arrow) with the bended hose from heater.

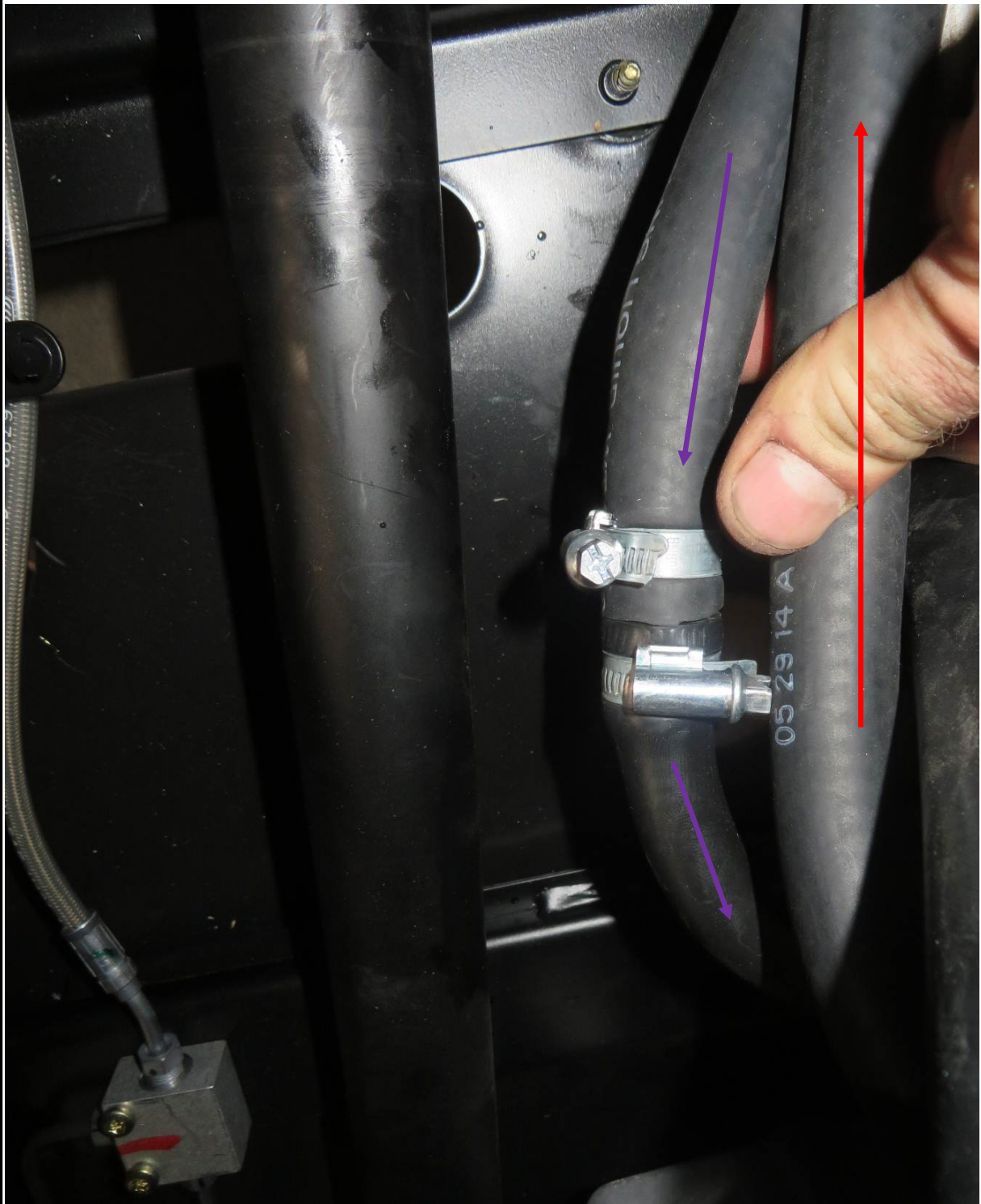

18

Secure vertical original hot water hose (with red line) near the left wheel by pliers or clamps. Cut the vertical hose between the pliers and insert the tightening straps onto the hose.

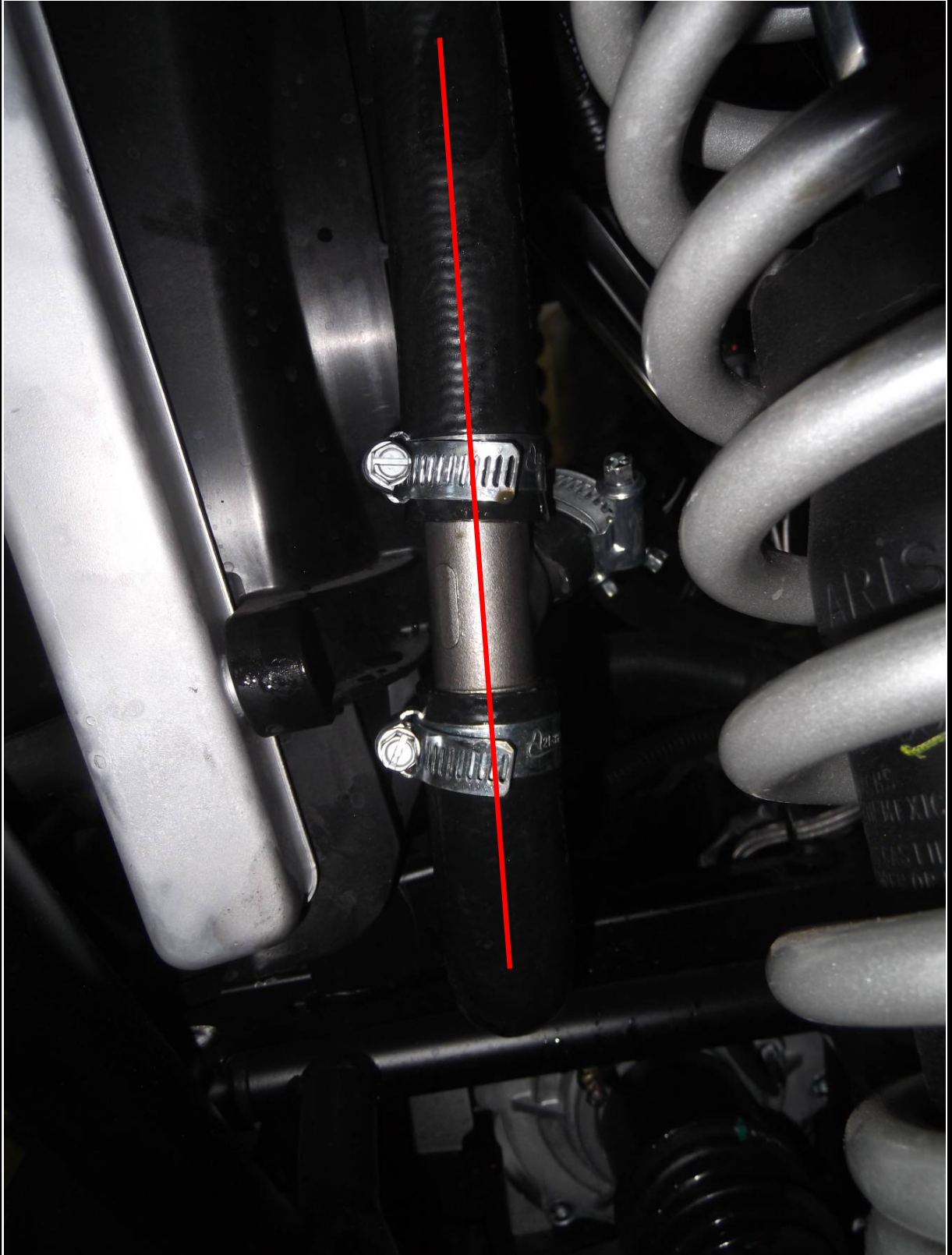

19

FOR ALL TECHNICAL QUESTIONS, PLEASE CALL
DFK AMERICA INC.
(630) 324-8585

Insert the "Y" couple into the original hole. Insert the tightening strap onto the hose from heater and insert that hose onto the "Y" couple. Tighten all straps very hard and take out the pliers.



20

FOR ALL TECHNICAL QUESTIONS, PLEASE CALL
DFK AMERICA INC.
(630) 324-8585

Cut the heater hose near "Y" coupling from previous page and insert the tightening straps. Install the air vent valve into the hose and fix these by straps. Tighten straps very hard.



Drill 1 hole \varnothing 11,5-14mm (0,45-0,55 in) and 2 holes \varnothing 2,5-4 mm (0,1- 0,16 in) into the dashboard in accordance with the ventilator switch base (red circle).



FOR ALL TECHNICAL QUESTIONS, PLEASE CALL
DFK AMERICA INC.
(630) 324-8585

Lead the harness branches No.:1 and 2 from the heater to the UTV switch panel.
Connect the heater switch body with the harness branch No.:1. Detail view.

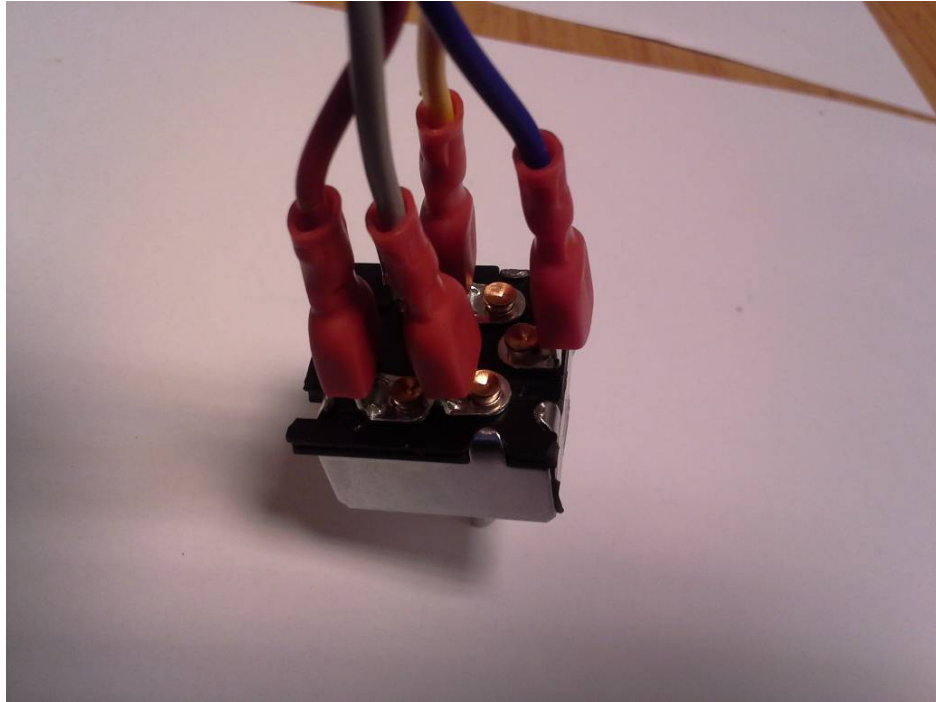

Insert the switch body with the harness and with the serrated-lock washer into the prepared hole from page No.: 23(upper picture) from inside. Place the switch base onto the dashboard and onto the pin of the switch body.



Fix the switch with the switch base to dashboard by nut. And place the plastic had onto the switch pin.



Drill hole \varnothing 21 mm (red circle) for electromagnetic vent switch.



FOR ALL TECHNICAL QUESTIONS, PLEASE CALL
DFK AMERICA INC.
(630) 324-8585

Pull the harness branch No.: 2 through the hole from previous page (bottom picture) and connect the branch with the switch. Detail of connection.

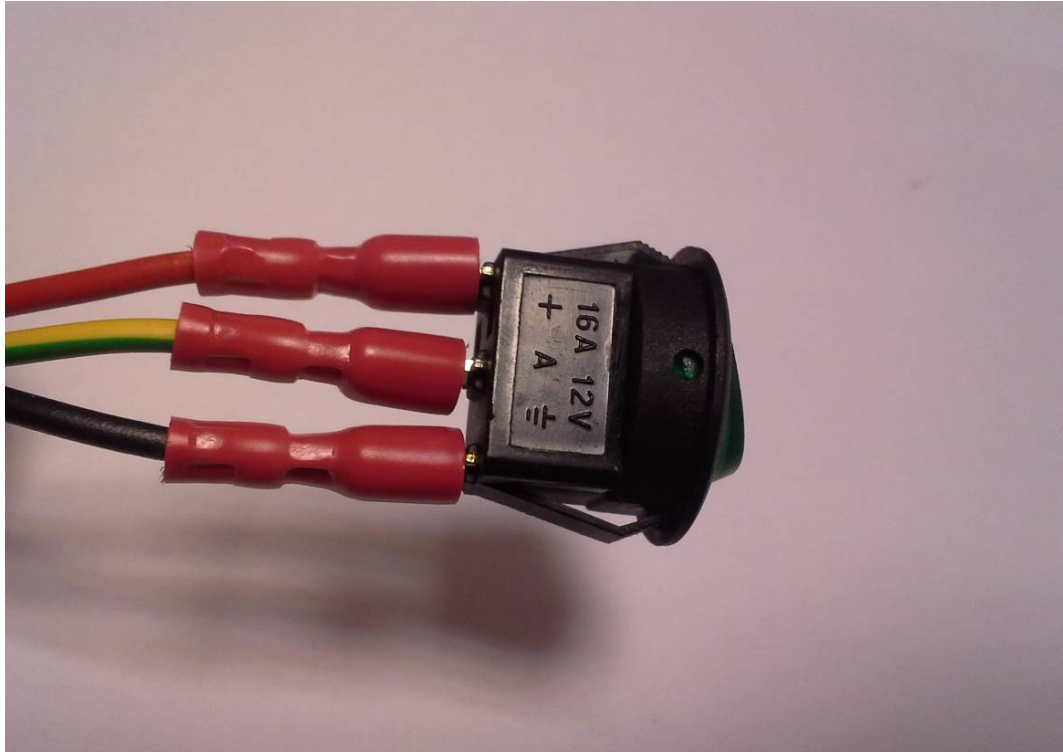

Connect the branches with the UTV' electroinstallation. Detail of connections.

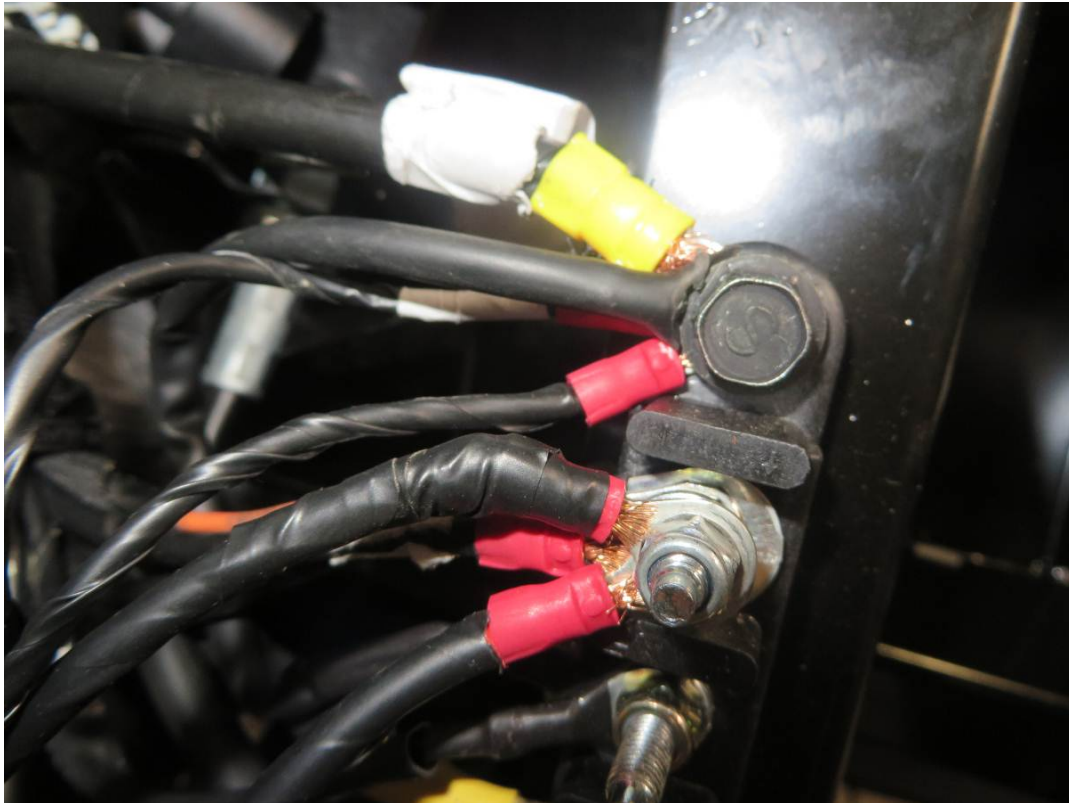

FOR ALL TECHNICAL QUESTIONS, PLEASE CALL
DFK AMERICA INC.
(630) 324-8585

Make marks onto the dashboard and drill hole $\varnothing 8$ mm (0,31-0,33 in) into the marks center. Cut the holes $\varnothing 56$ mm (2,2 in) into the dashboard (red circle), use hole from previous step like pivot on both sides.



Cut the edge carefully from inner side. Repeat these steps on right dashboard side. Insert the air hose into the heater air tube and fix by included "AL" self glued tape.



FOR ALL TECHNICAL QUESTIONS, PLEASE CALL
DFK AMERICA INC.
(630) 324-8585

Lead air hoses to the roller cage. Insert air vent smaller into the hole. Insert tightening strap onto the air hose and insert the air hose onto the air vent smaller. Tighten strap hard.



26

Make marks in accordance with the air vents and and cut the holes $\varnothing 76\text{mm}$ (3 in) into the mark's centers.

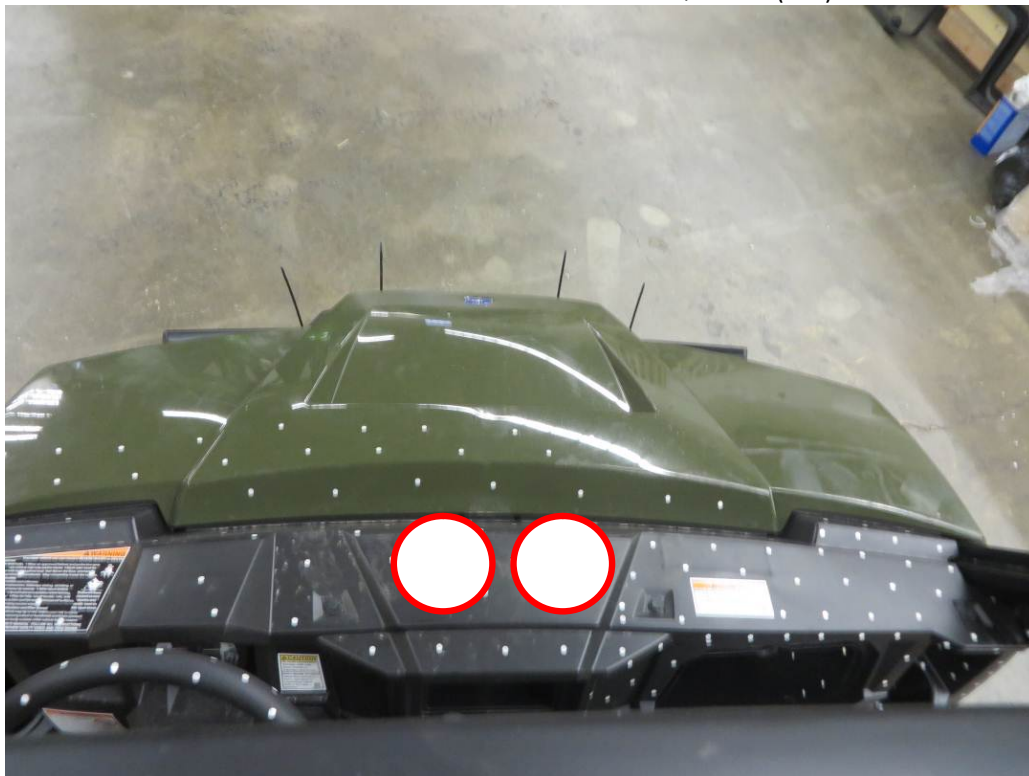

FOR ALL TECHNICAL QUESTIONS, PLEASE CALL
DFK AMERICA INC.
(630) 324-8585

Cut the hole's edges from inner side. Insert the air hoses into the heater air tube and fix by AL selfglued tape. Insert air vent straight into the holes from previous page and insert the air hose onto the air vent. Fix the hose with the vents by tightening straps and tighten hard.



It is absolutely necessary to bleed the air out of the UTV's engine cooling system. Incomplete bleeding of cooling system can result in engine damage. If you don't have sufficient experience with this process, we strongly recommend professional service technician assistance. We are not responsible for damages when cooling system bled incompletely. Please note that additional heater system will absorb more than 2 liters of coolant fluid.

- 1. Important: After the heater system installed check the system for leaks. Turn on the electric vent switch and confirm that the engine is cold. Start the engine, open bleeding valve and wait until engine warms up. Important: Always check engine temperature – if it overheats turn off engine.***
- 2. To achieve engine operating temperature depress the accelerator to increase the engine RPM. This will increase the pressure and flow of the water pump forcing more coolant through the heater. After operating temperature reaches turn off engine and open it. Trapped air should come out from heater system throughout bleeding valve. Repeat this procedure until heater/cooling system is completely bled out.***

The DFK Cab heater, like the heater in a car, generates heat from the vehicle's engine.

In nearly all cases, the heater should generate enough heat from your UTV, side by side, or tractor engine that you may need to turn the heater off periodically otherwise the air in the cabin may be too hot.

It is important to check the coolant level regularly at least 4-5 times during the first several days of operation and fill as necessary until the coolant level has stabilized. The heater will draw and retain coolant, sometimes at the expense of coolant to the engine. This can cause engine overheating if not managed properly.

IMPORTANT NOTE FOR POLARIS RANGER 570 MIDSIZE VEHICLES AFTER 2016.

During the installation you may encounter interference from the shoulder restraint bars on either side of the ROPS frame. These restraints need to be either bent inward approx. 1" or removed for the door to close properly.

LEFT DOOR + RIGHT DOOR 1.

Press the rubber profile - pirea side onto the UTV rear plastic cover in order to seal the gap between the rear plastic cover and the UTV roller cage on both sides.

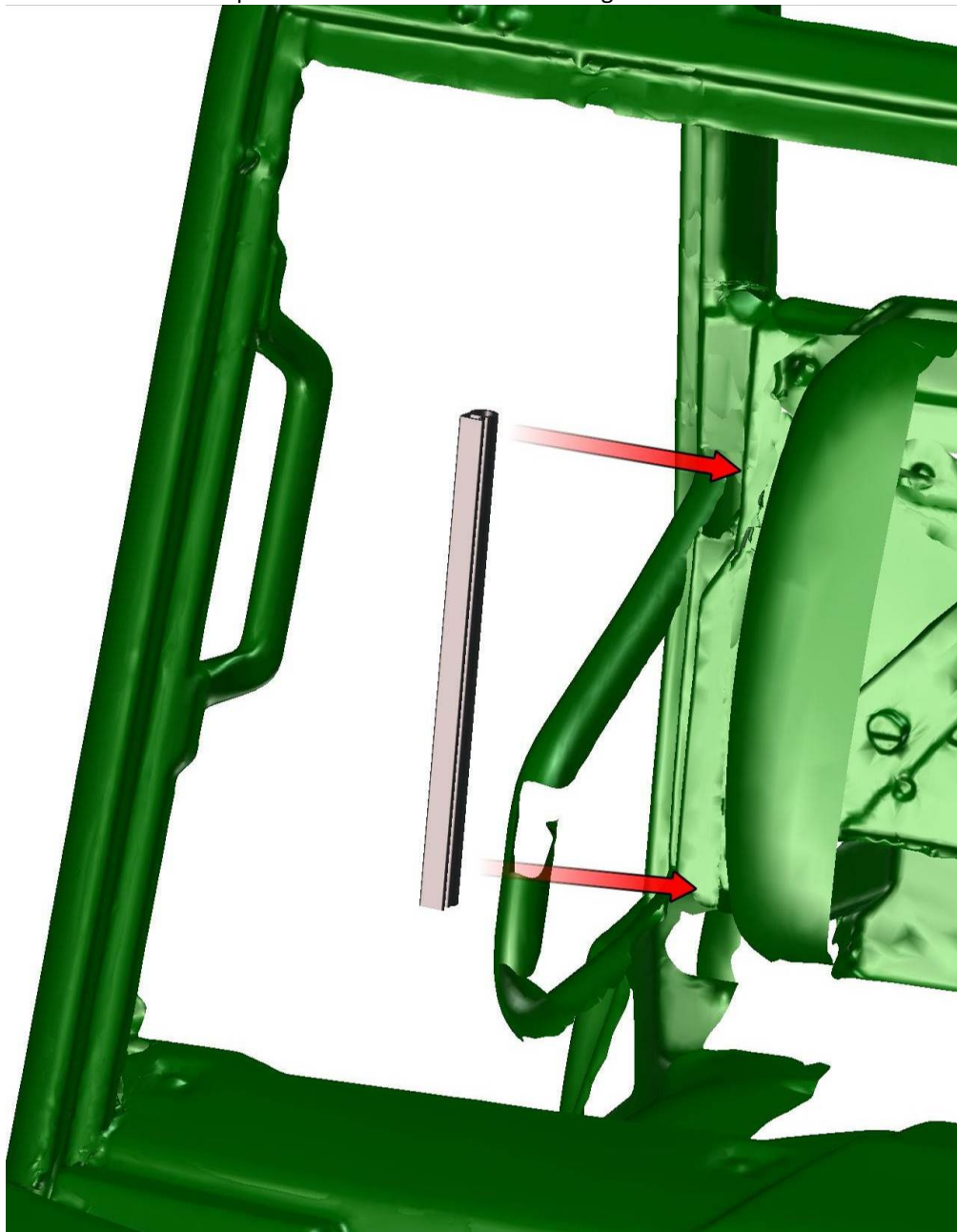

FOR ALL TECHNICAL QUESTIONS, PLEASE CALL
DFK AMERICA INC.
(630) 324-8585

Uninstall original screws from UTV roller cage (red circle) on both sides.



30

Place the right hinges onto the right door base and fix the hinges with the base by screws, washers, nuts and covers.

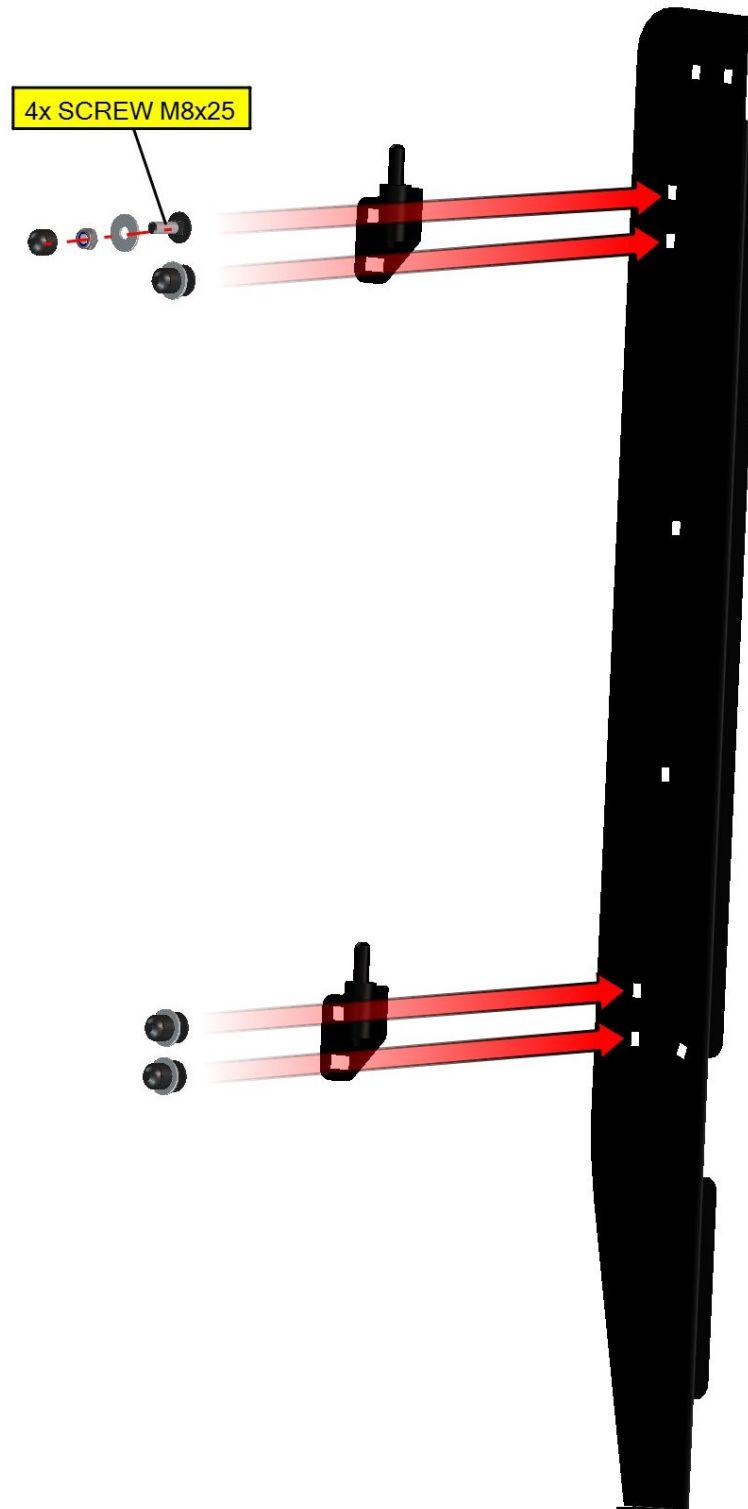

Place the right door base onto the UTV roller cage.



Fix the right door base with the UTV roller cage by included holders, screws, washers, nuts and covers.
Adjust the right door base into the best position and tighten screws hard.

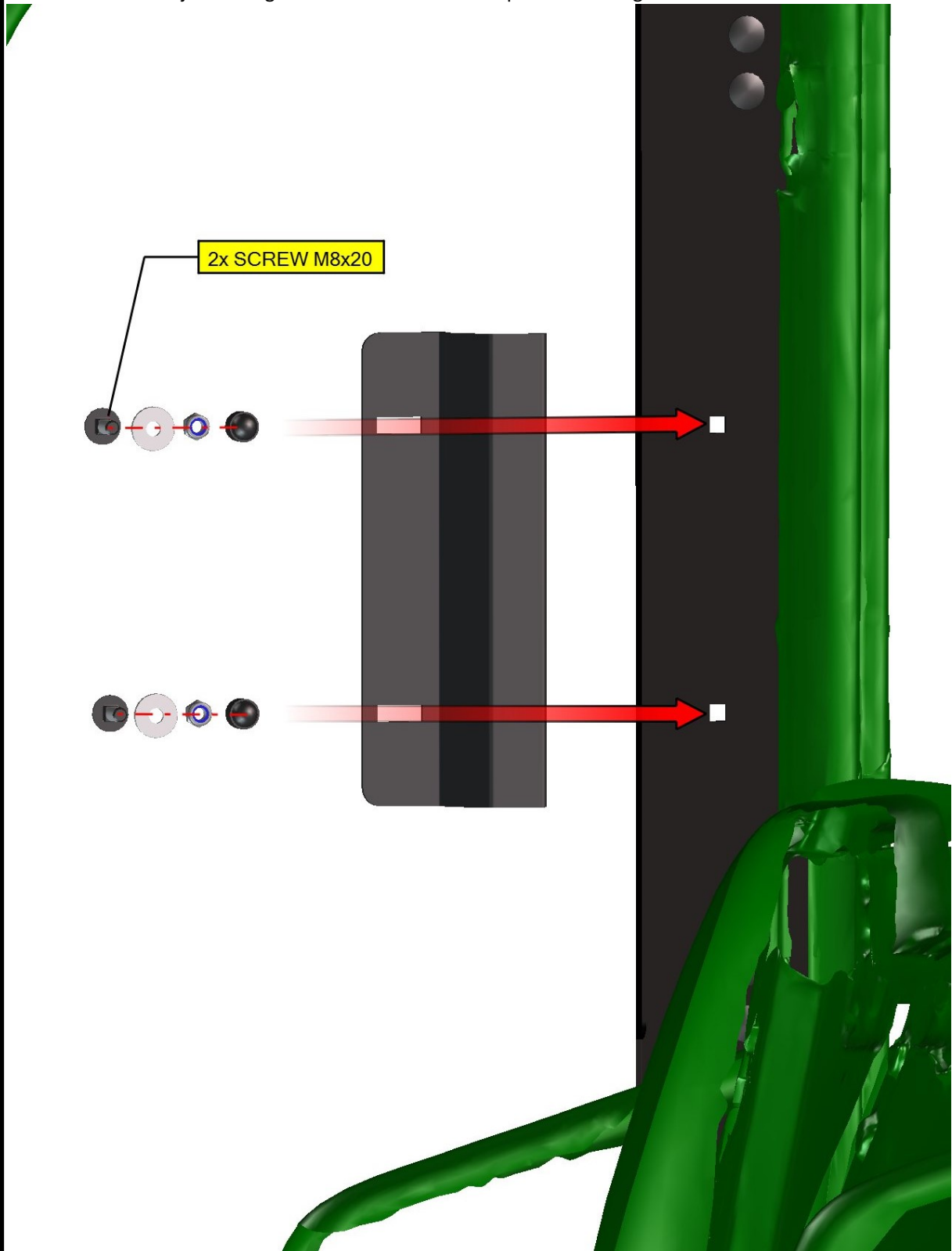

33

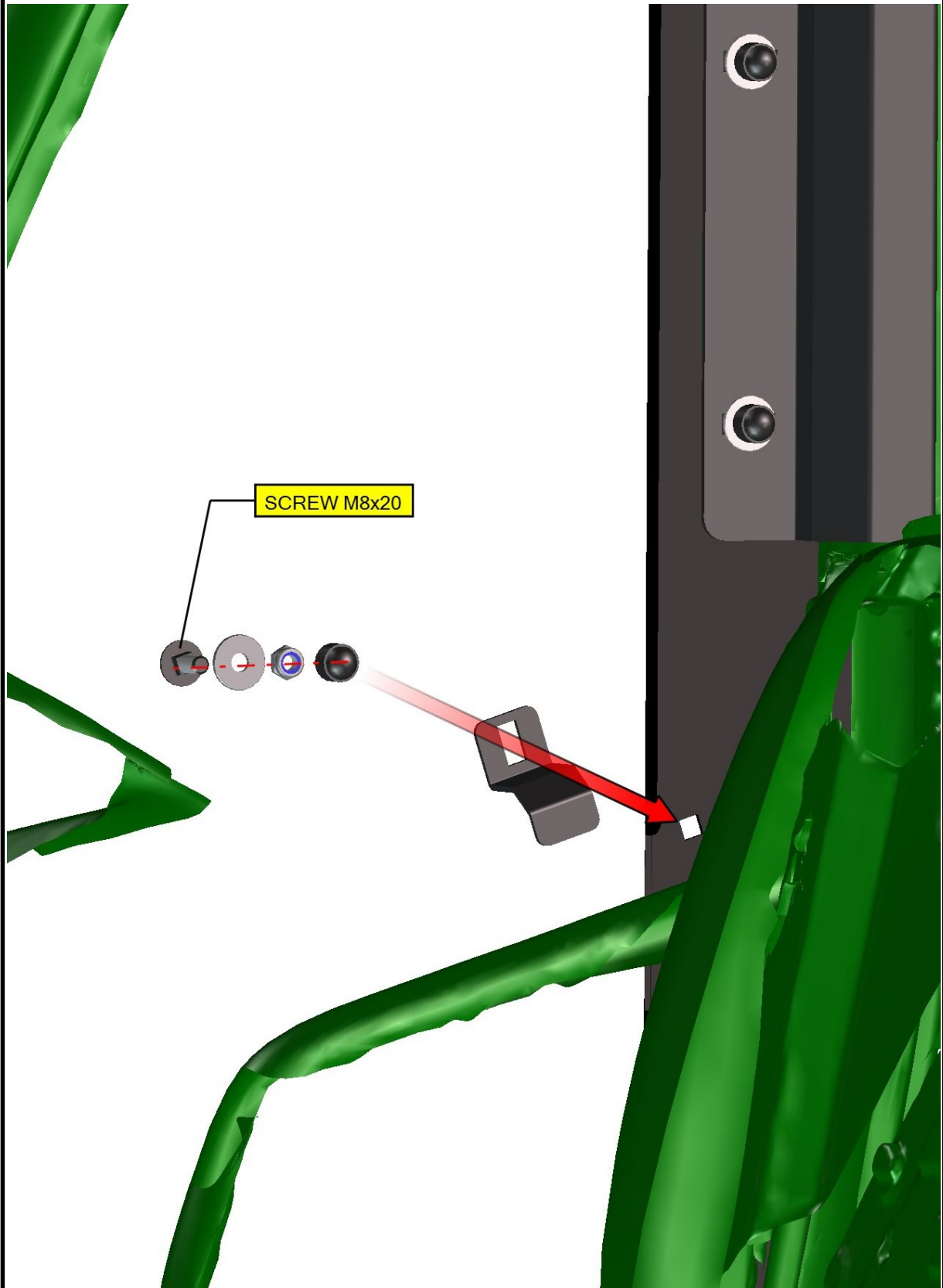

34

Place the upper door base holder onto the door base and insert included screws into the holes.

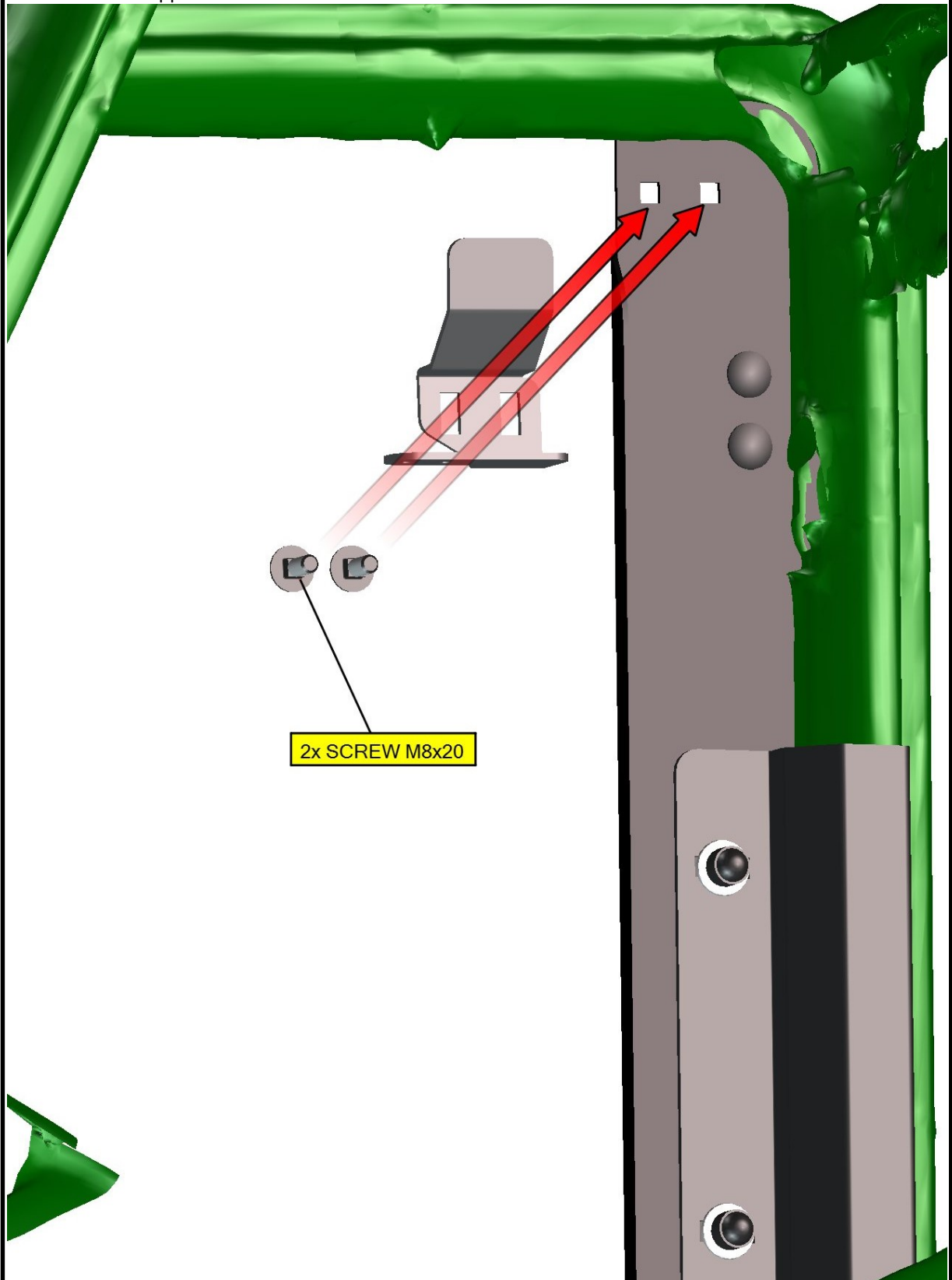

35

Place the upper door base holder ledge onto the upper door base holder screws. Fix by included nuts, washers and covers.

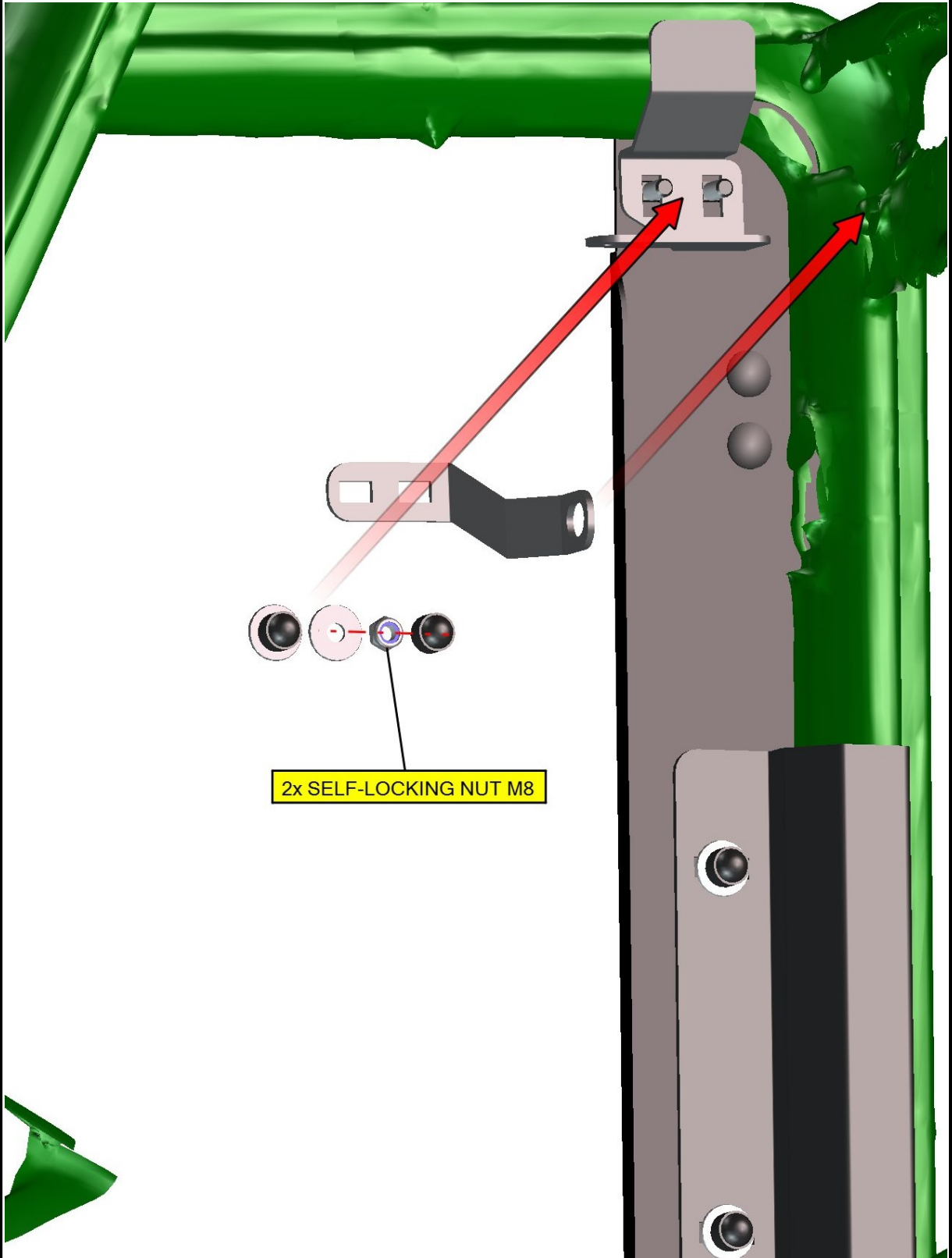

Fix the upper door base holder ledge with the UTV roller cage by original screw.

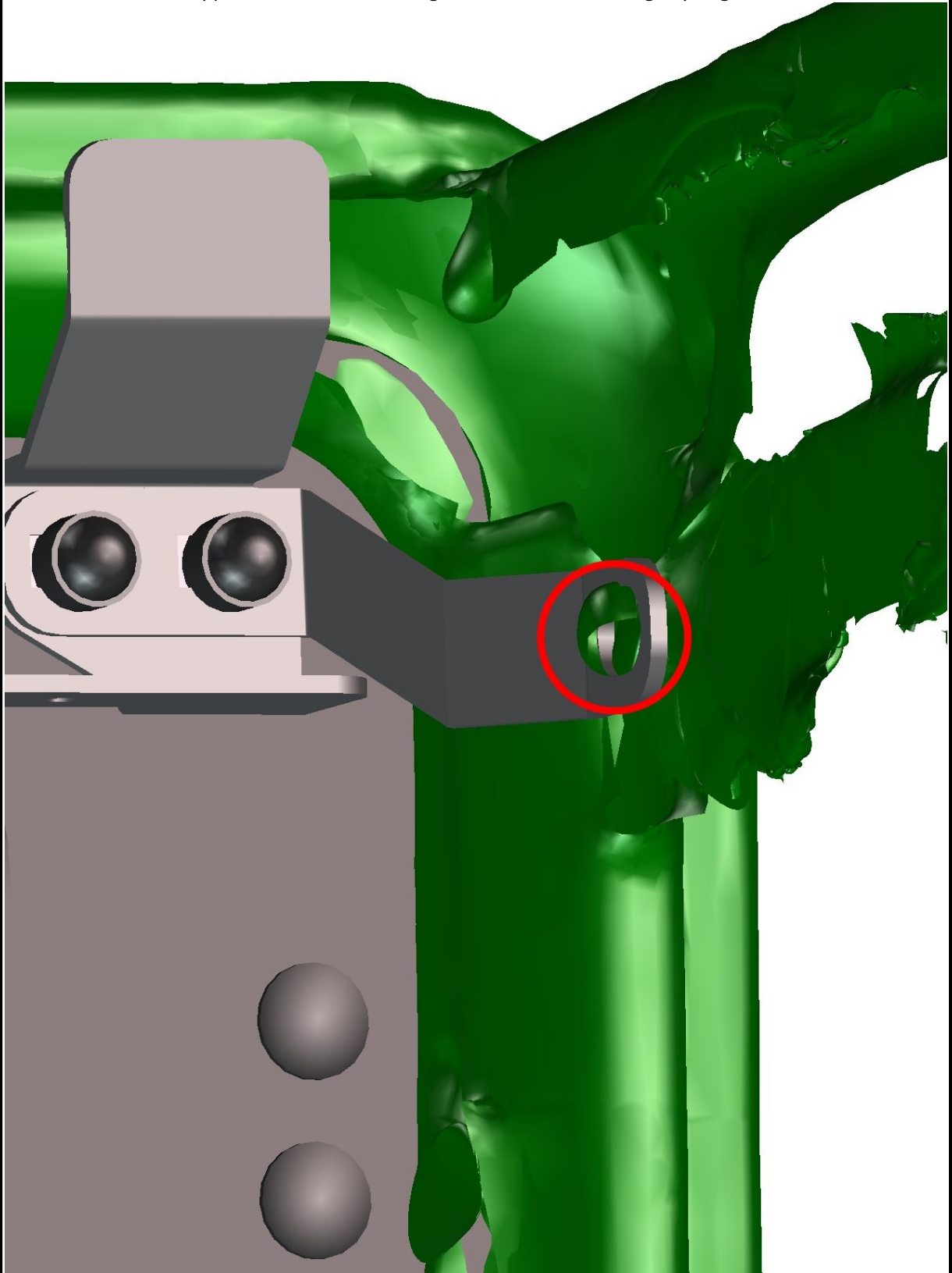

37

Fix the right door base with the UTV plastic cover by included rubber rivet. If necessary drill hole $\varnothing 8\text{mm}$ into the UTV plastic cover in the center of right door base bottom hole.

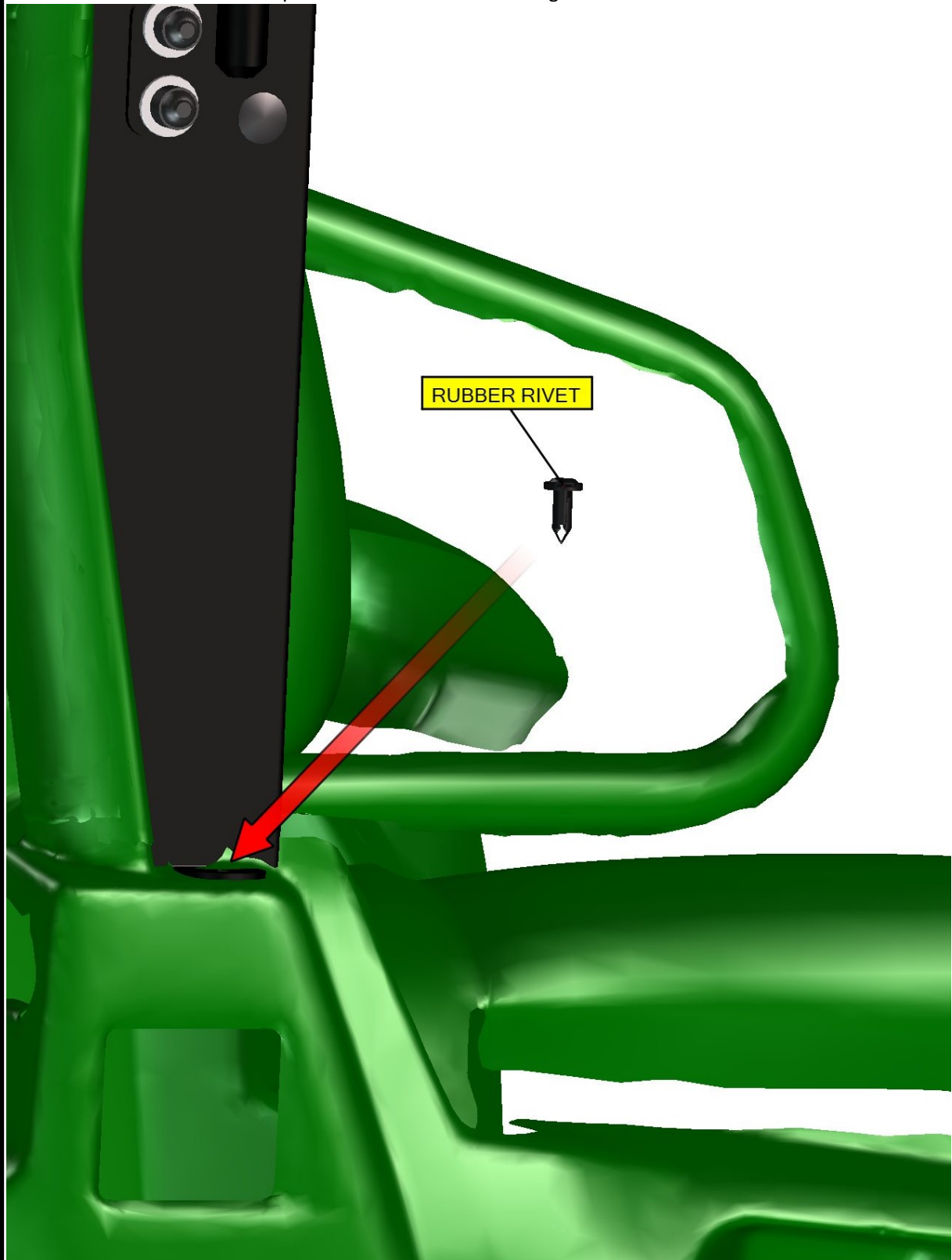

38

REPEAT PREVIOUS STEPS WITH THE LEFT DOOR BASE.



REAR PANEL

Uninstall the original screw (red circle) from the rear part of UTV roller cage on both sides.

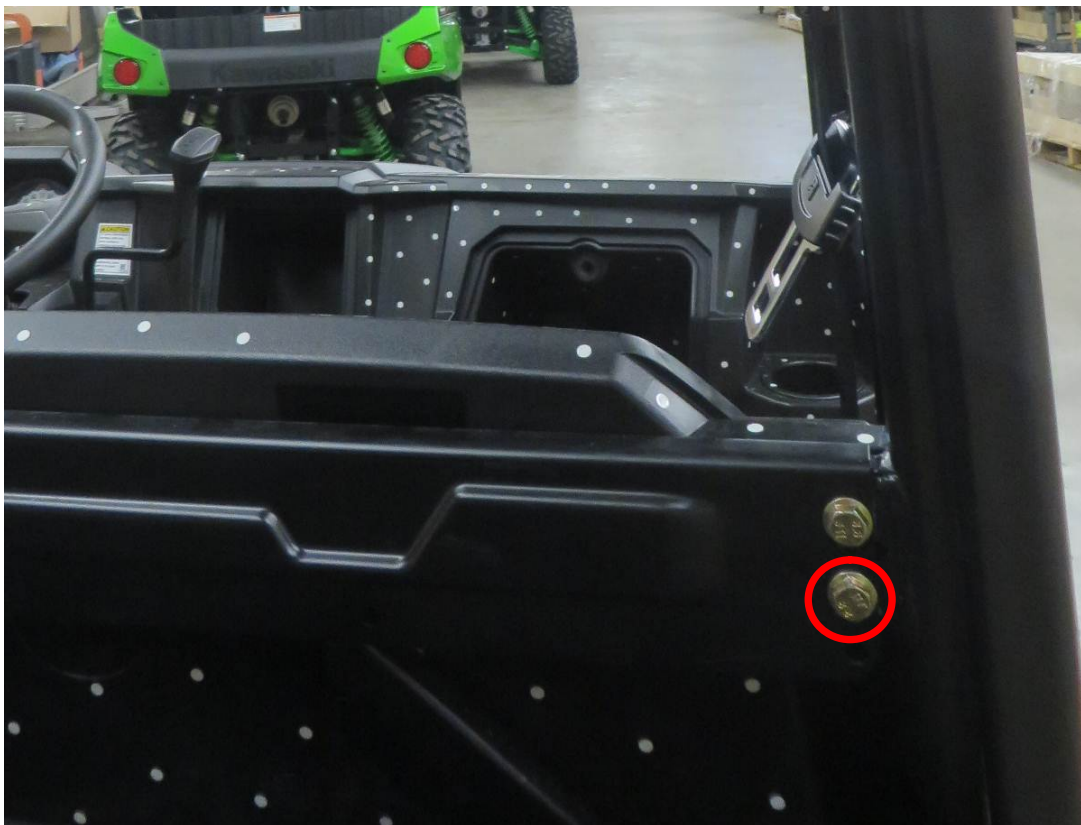

Place the rear bottom ledge onto the UTV roller cage.

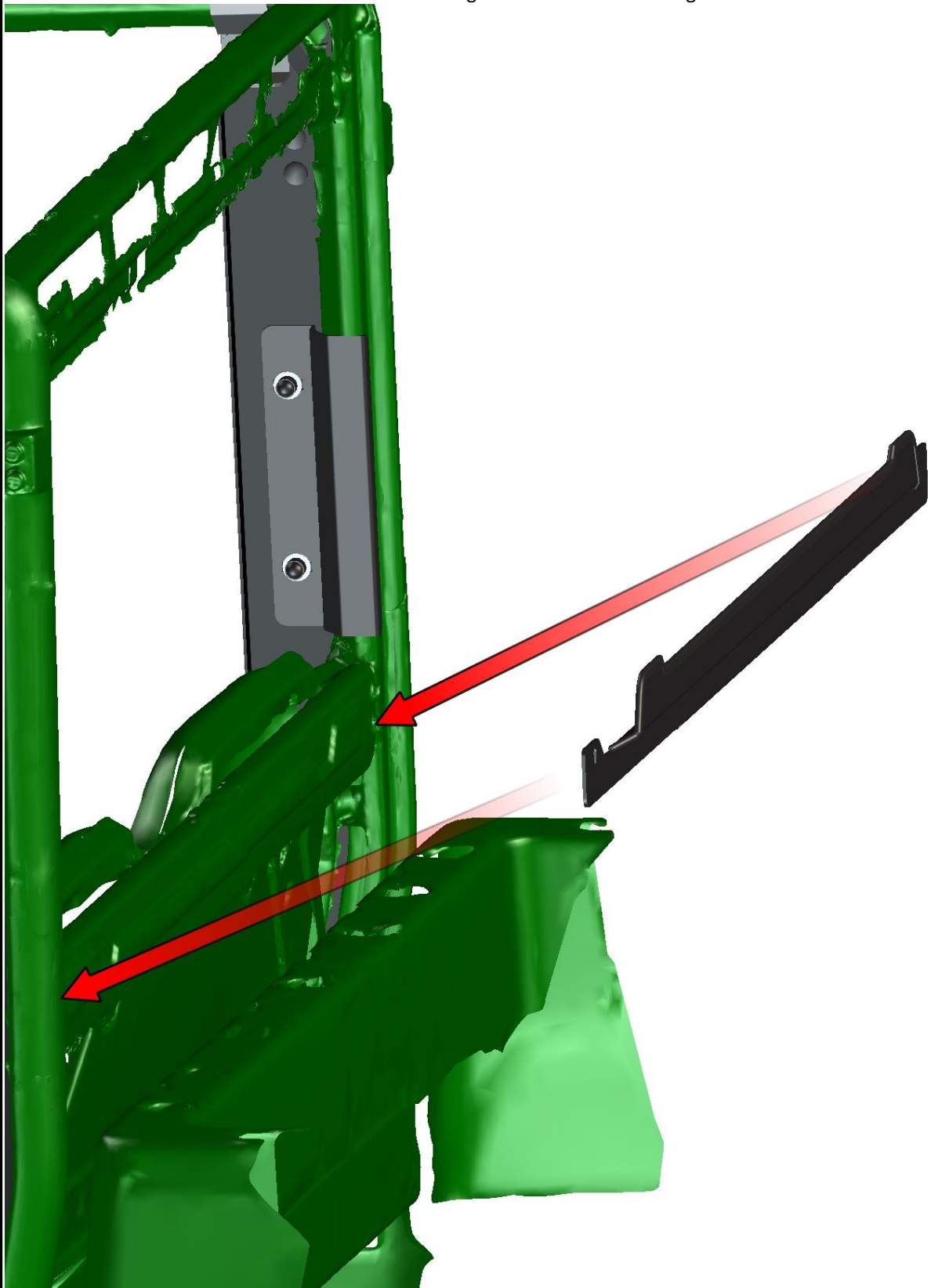

Fix the rear bottom ledge with the UTV roller cage by original screws on both sides.

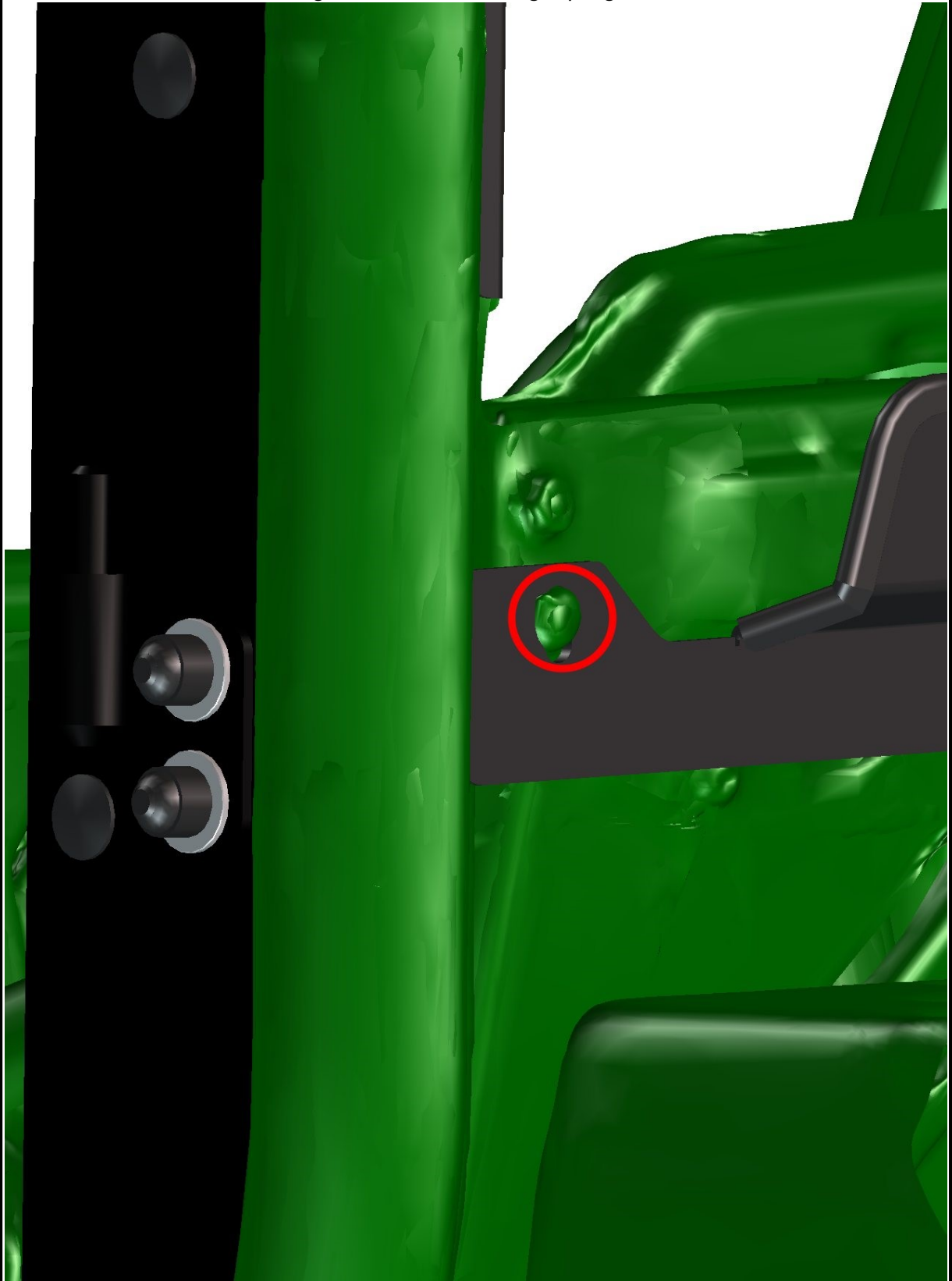

42

Install the rear window onto the rear bottom ledge.

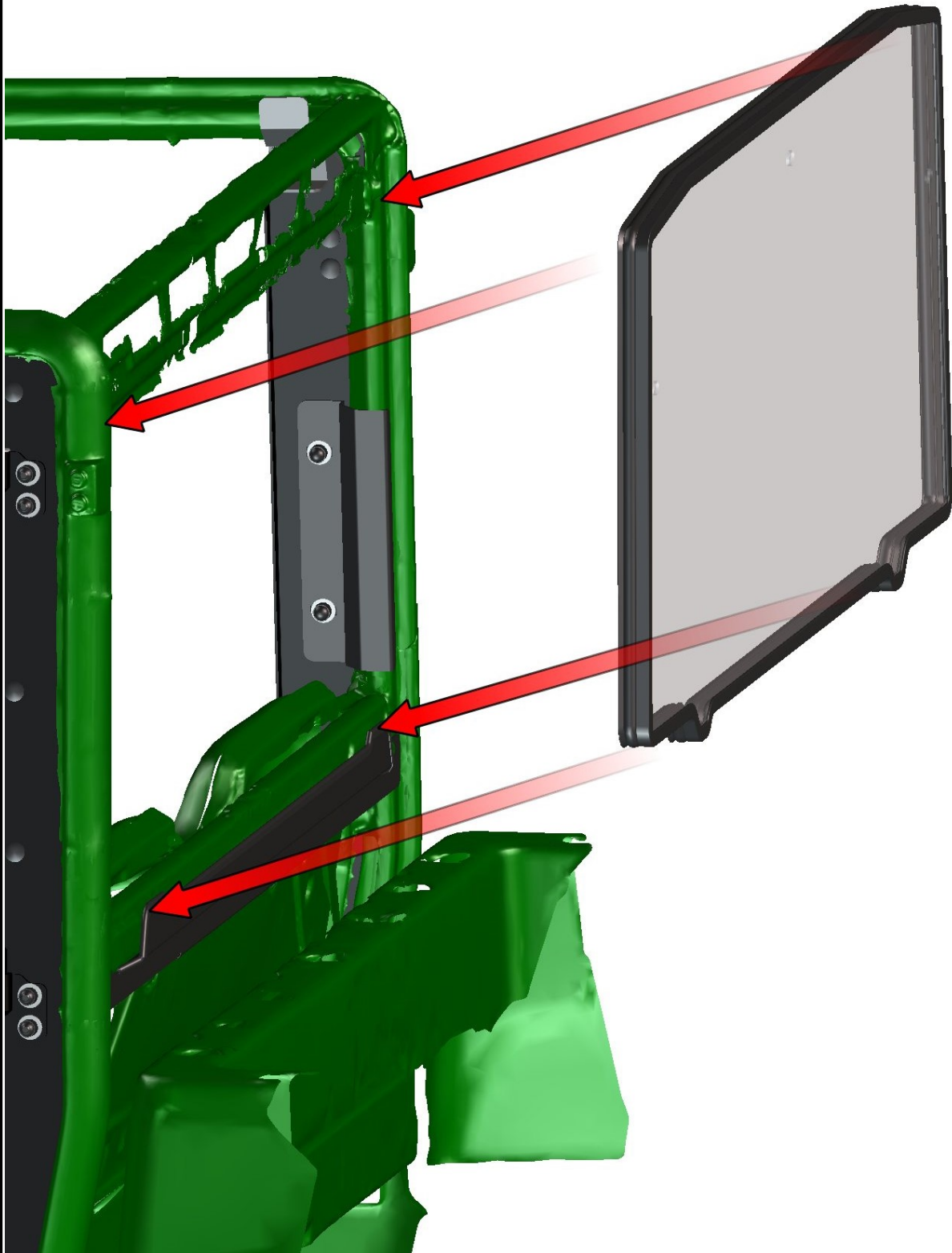

43

Fix the rear window with the UTV roller cage by included holders, screws, washers, nuts and covers on both sides.

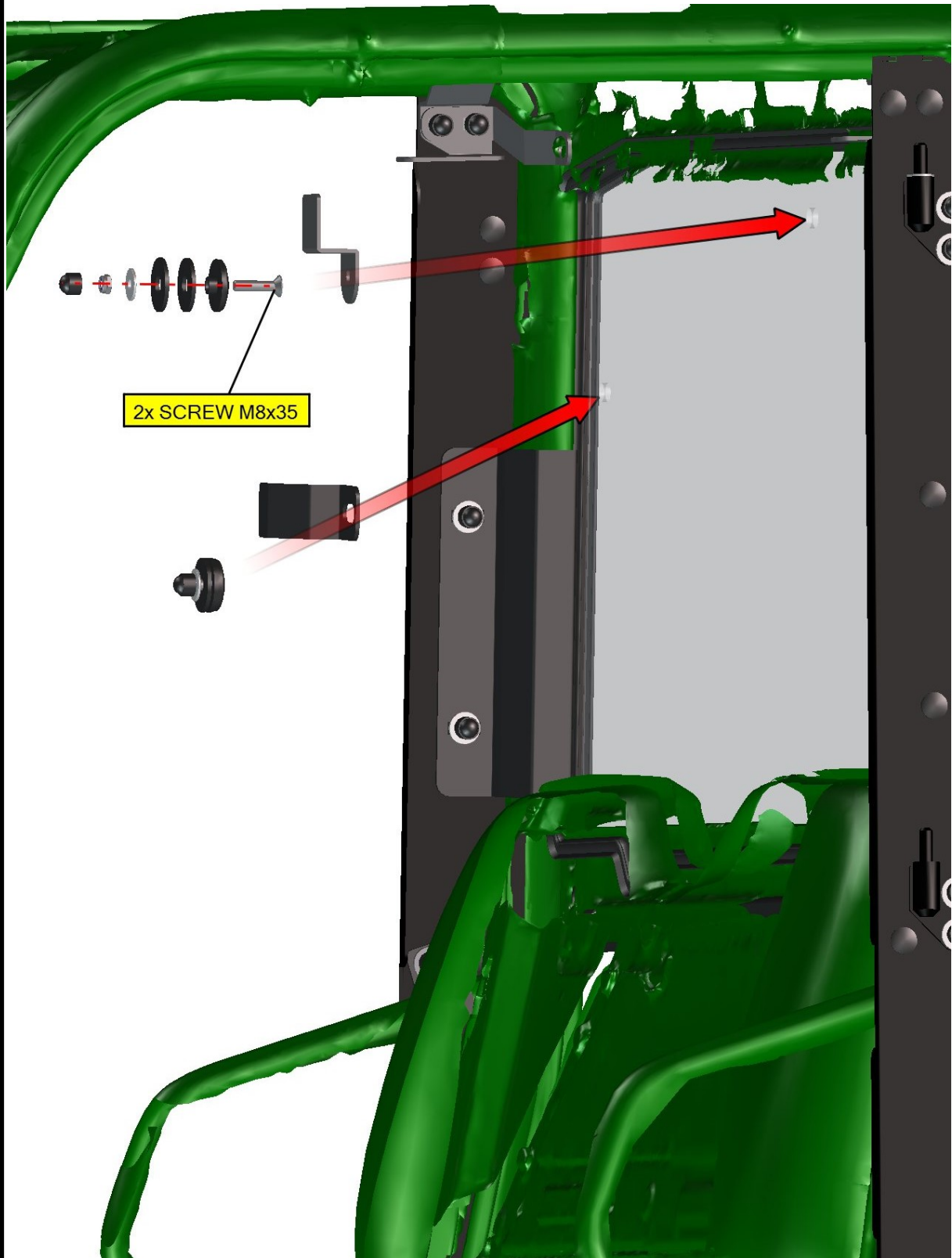

FRONT PANEL

Install the front bottom ledge holder onto the UTV original lath holes (red circle) on both sides.

SEE NEXT PAGE



45

Fix the front bottom ledge holder with the UTV lath by included screws, washers, nuts and covers on both sides.

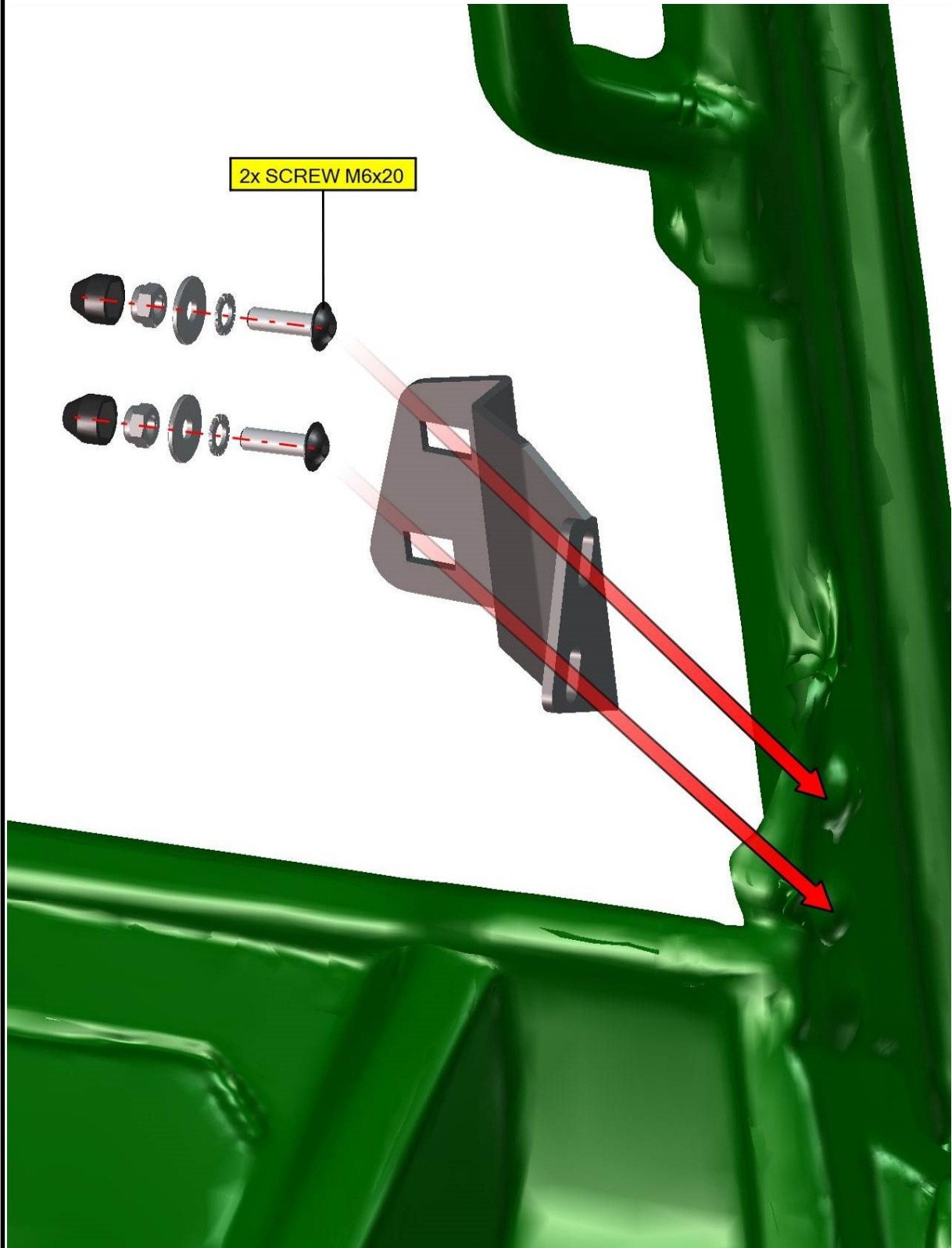

Place the front bottom ledge onto the UTV roller cage in accordance with the front bottom ledge holders holes.

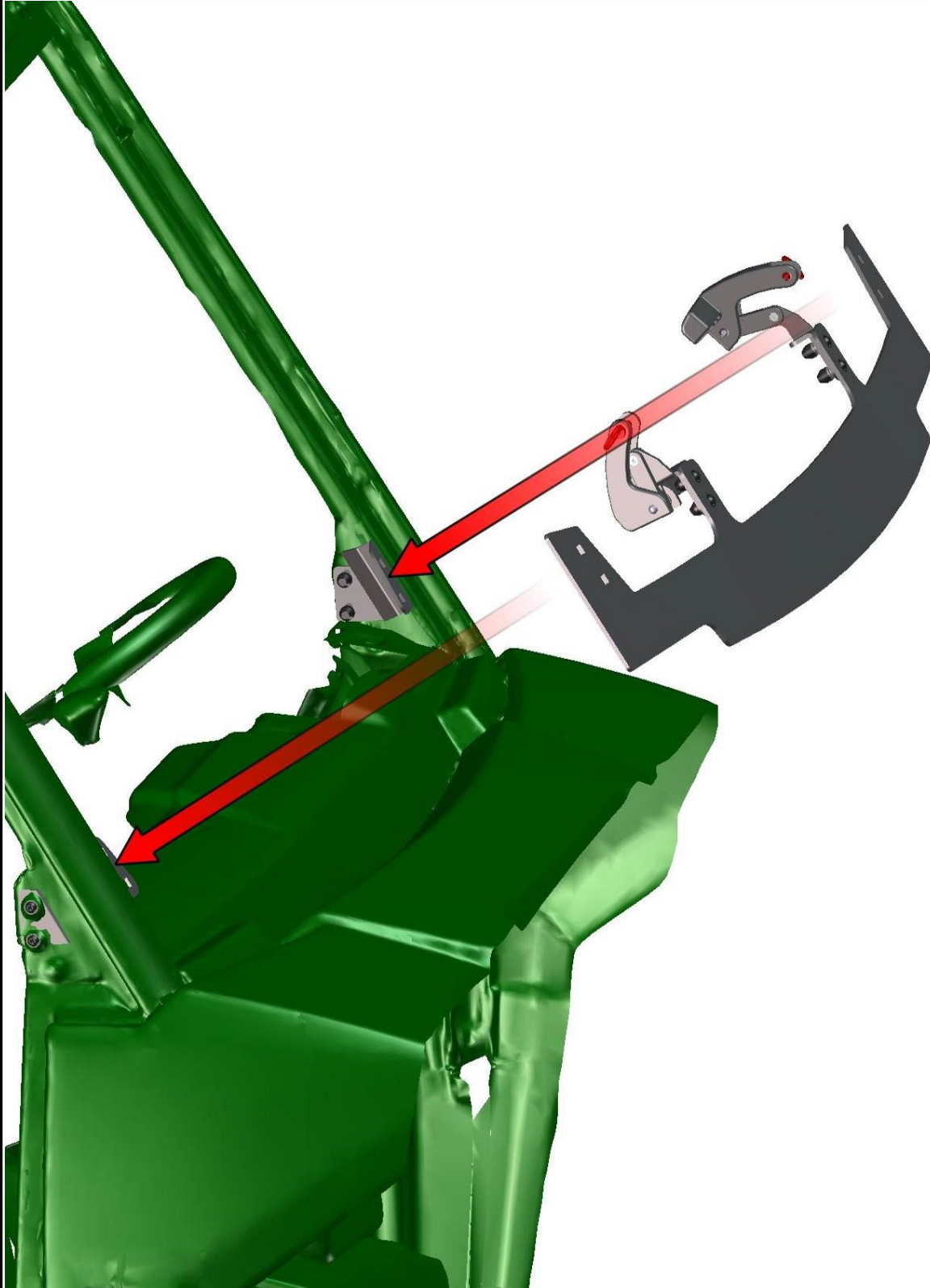

47

FOR ALL TECHNICAL QUESTIONS, PLEASE CALL
DFK AMERICA INC.
(630) 324-8585

Place the front gas spring holder onto the front bottom ledge holder and fix by included screws, washers, nuts and covers on both sides.

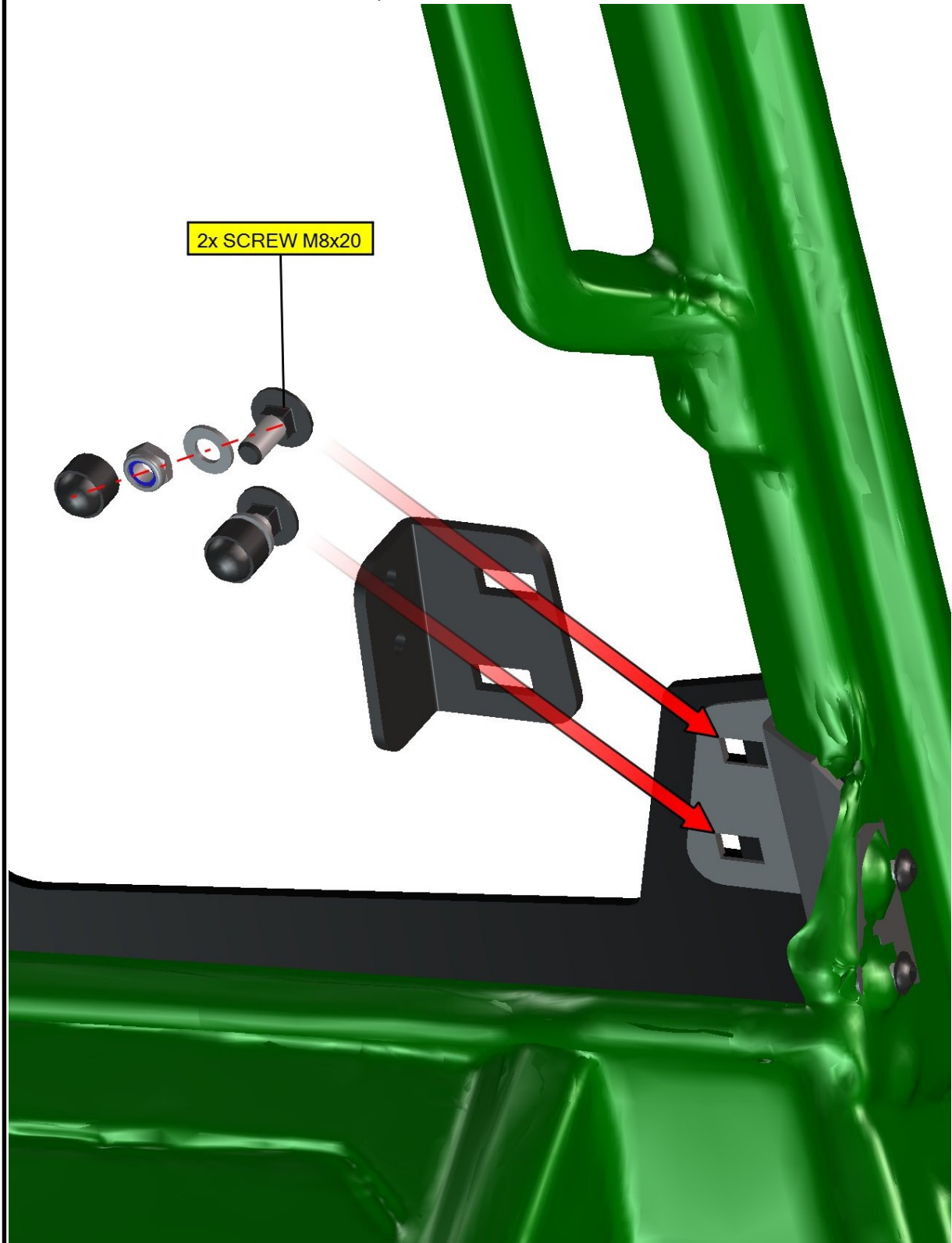

48

ELECTROINSTALLATION – WIPER SET

View onto the wiper motor with the cover and with the middle ledge.



Place the washer onto the wiper longer pin.



FOR ALL TECHNICAL QUESTIONS, PLEASE CALL
DFK AMERICA INC.
(630) 324-8585

Place the washer onto shorter wiper pin.



View onto installed washers.



FOR ALL TECHNICAL QUESTIONS, PLEASE CALL
DFK AMERICA INC.
(630) 324-8585

Place the wiper assembly onto the front glass from inner side.
Insert these washers onto the wiper's pins and onto the glass from outer side.



Fix the wiper motor with the front glass by included nuts and tighten these correctly.



FOR ALL TECHNICAL QUESTIONS, PLEASE CALL
DFK AMERICA INC.
(630) 324-8585

Place the front glass assembly onto the UTV roller cage by hinges. Fix the front glass assembly with the UTV roller cage by included screws, washers, nuts and covers using original holes.

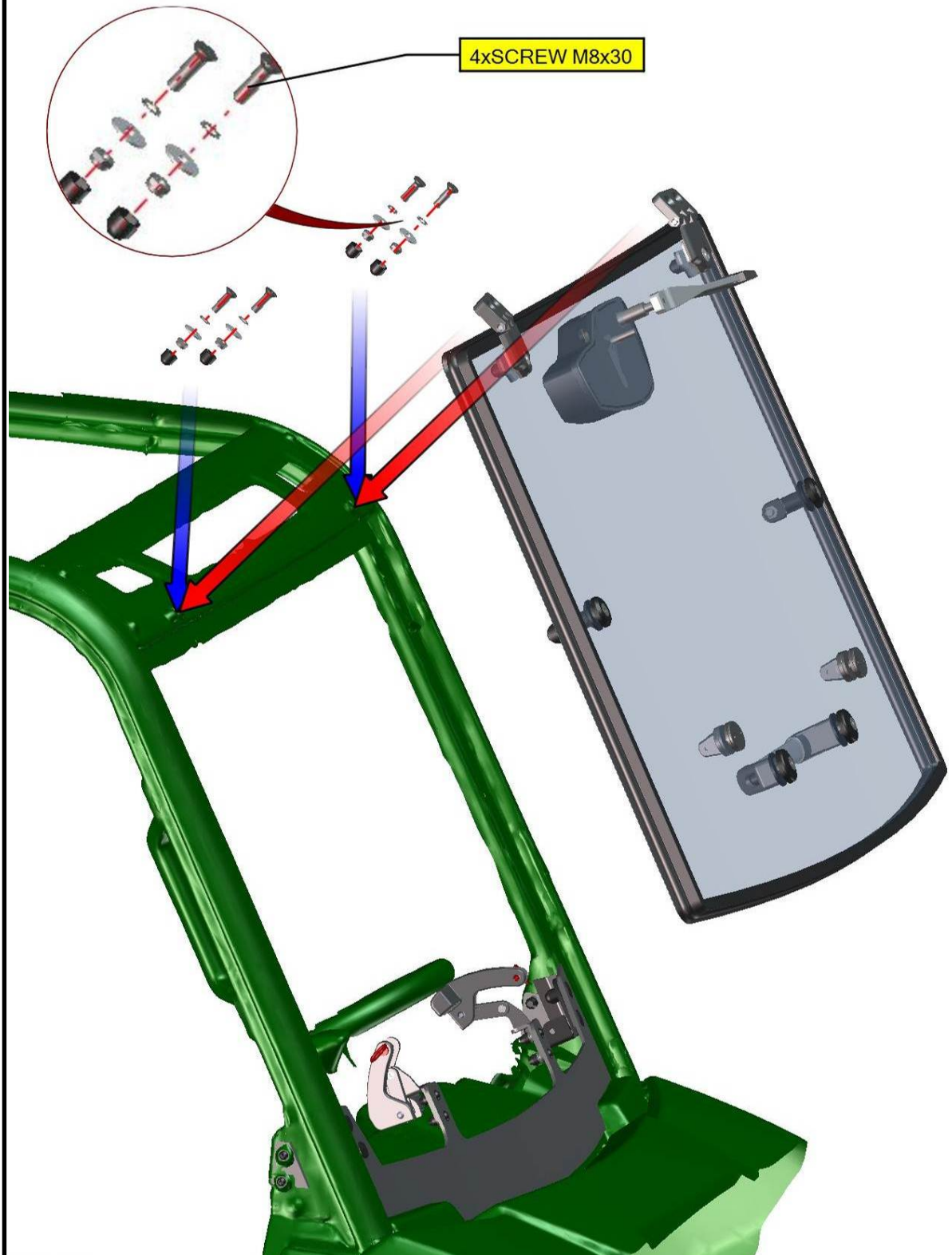

52

FOR ALL TECHNICAL QUESTIONS, PLEASE CALL
DFK AMERICA INC.
(630) 324-8585

Spray silicone from outer side into the roller cage gapes (red circle) on both sides.



53

SEE NEXT PAGES

FOR ALL TECHNICAL QUESTIONS, PLEASE CALL
DFK AMERICA INC.
(630) 324-8585

Adjust the glass lock to correct position and fix that by included pin on both sides.

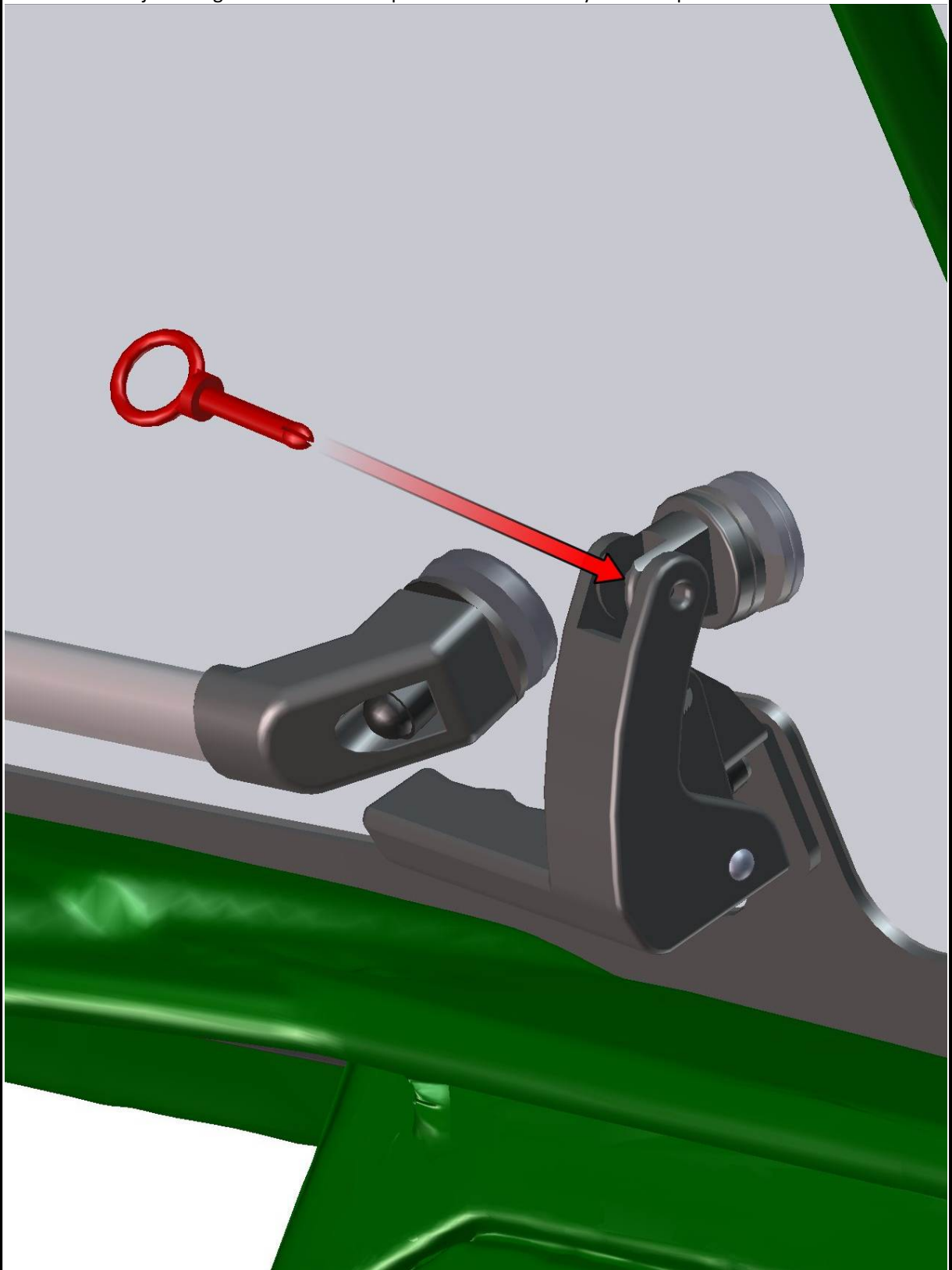

54

FOR ALL TECHNICAL QUESTIONS, PLEASE CALL
DFK AMERICA INC.
(630) 324-8585

Install the front gas spring into the front gas spring holders and fix by included nut, washers and cover on both sides.

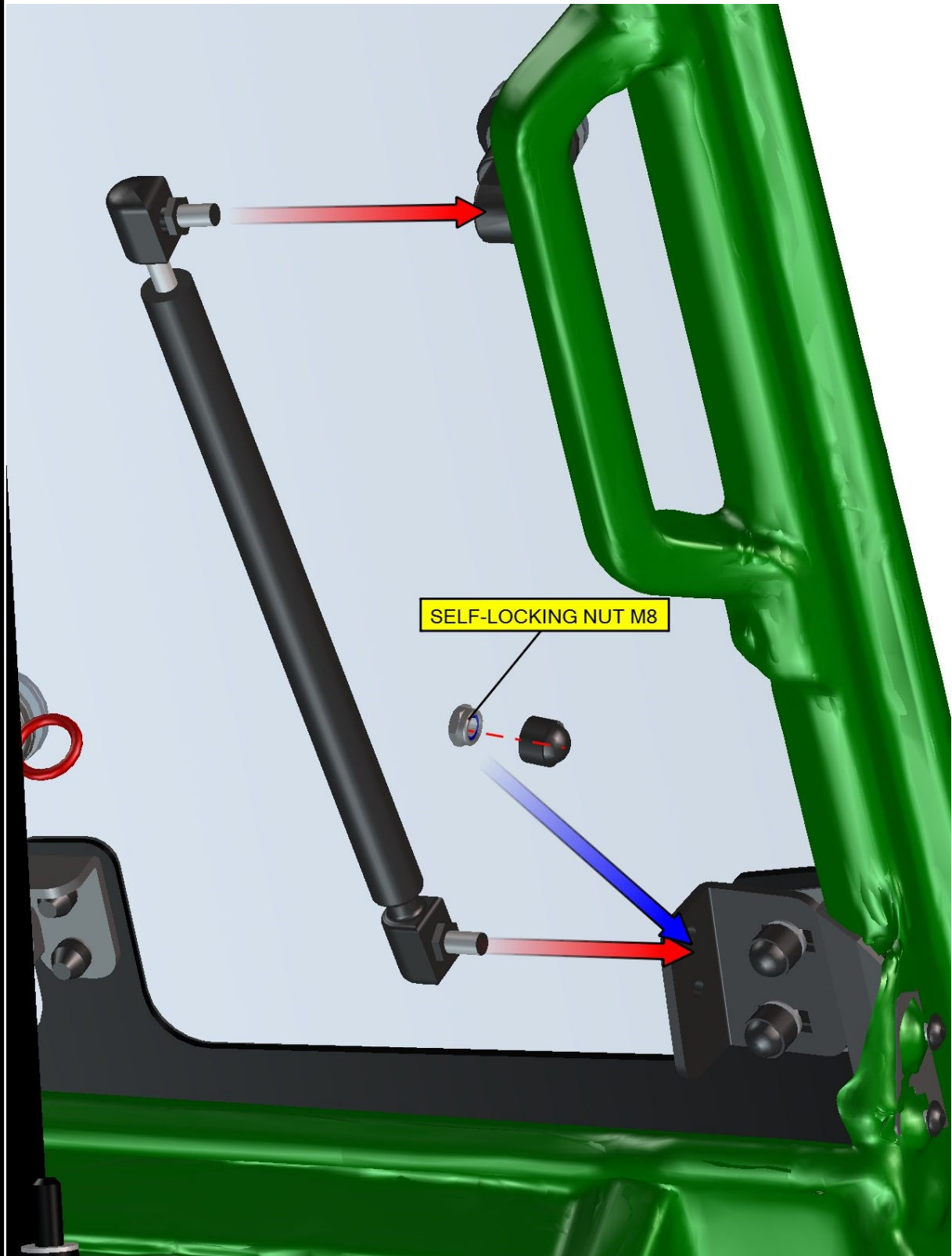

55

FOR ALL TECHNICAL QUESTIONS, PLEASE CALL
DFK AMERICA INC.
(630) 324-8585

ROOF

Install foam sealing onto the UTV roller cage (blue lines). Place the roof onto the UTV roller cage into the best position.

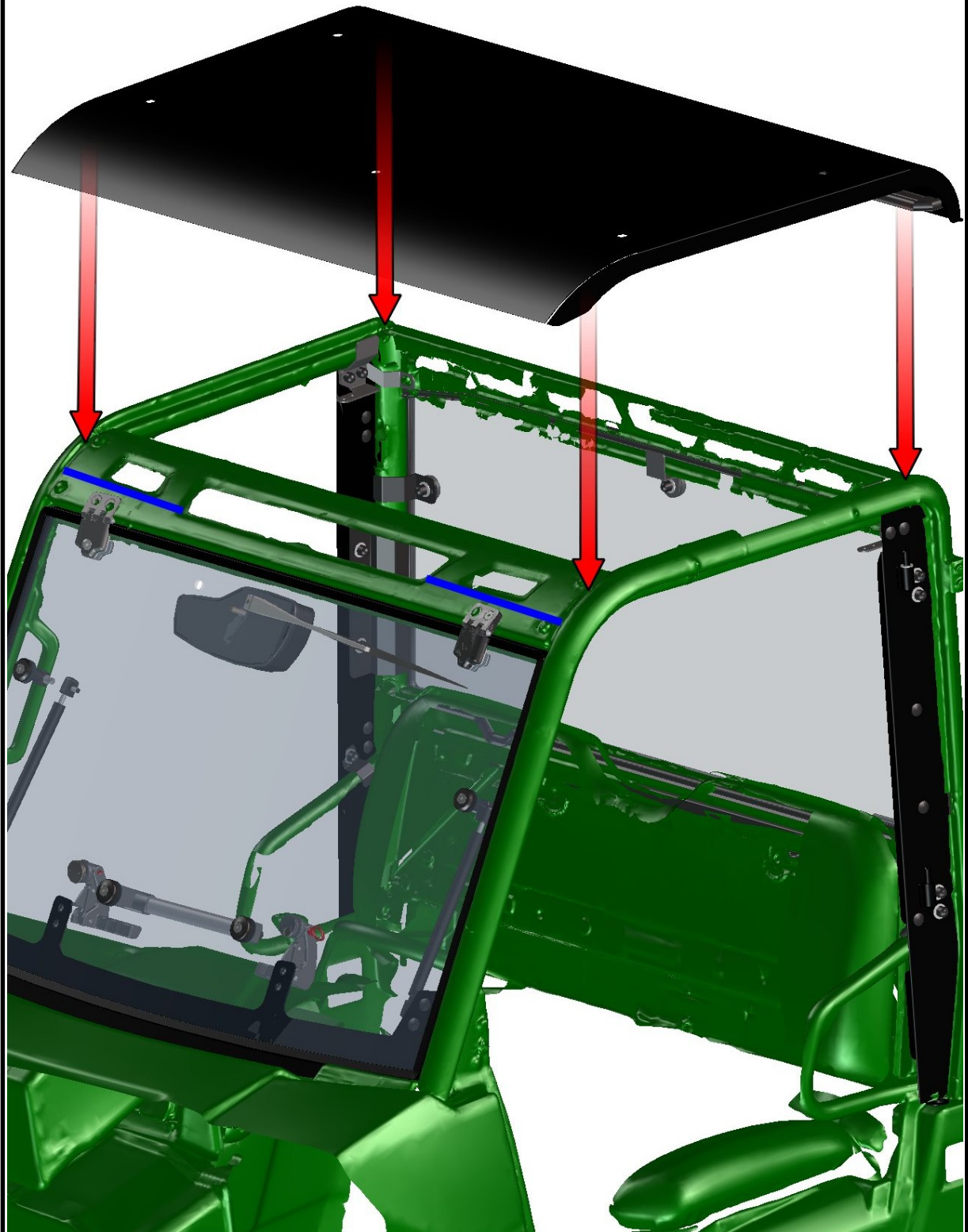

56

FOR ALL TECHNICAL QUESTIONS, PLEASE CALL
DFK AMERICA INC.
(630) 324-8585

Fix the roof with the UTV roller cage by included holders, screws, washers, nuts and covers on both sides.

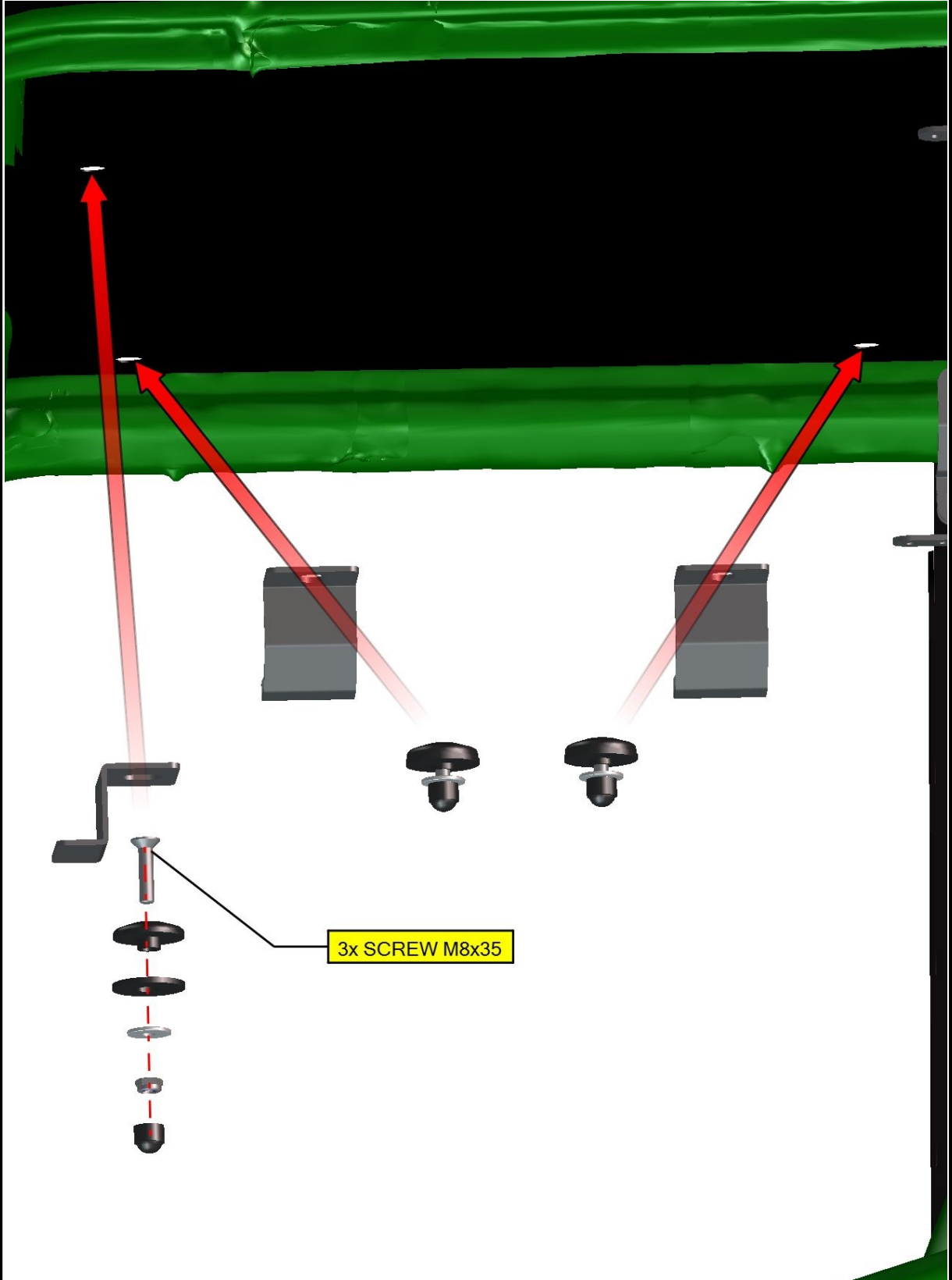

LEFT DOOR + RIGHT DOOR 2.

Lubricate the hinges pins and install the washers on them. Place the right door onto the hinges.

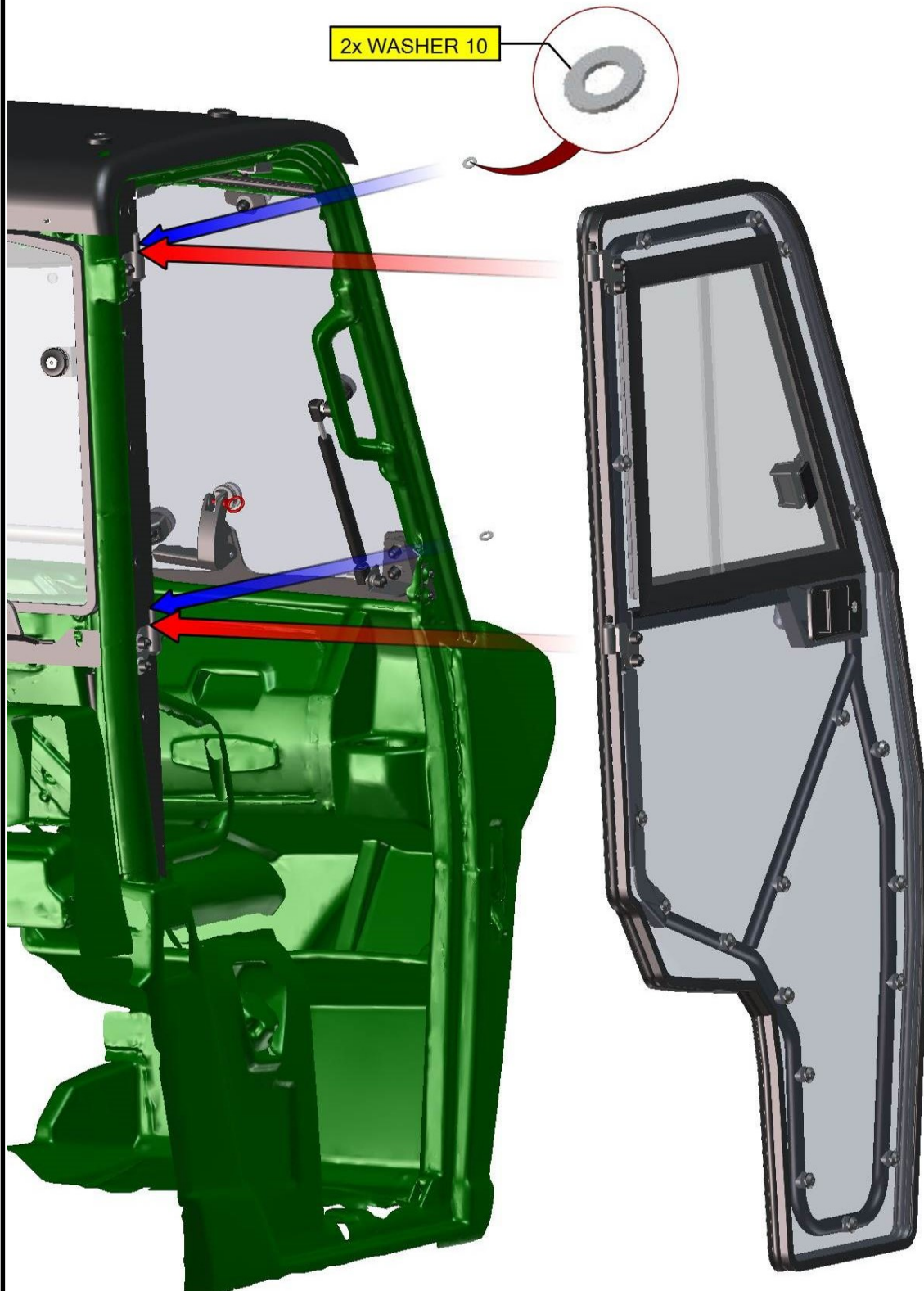

58

Adjust the right door into the best position by hinges and tighten screws correctly.

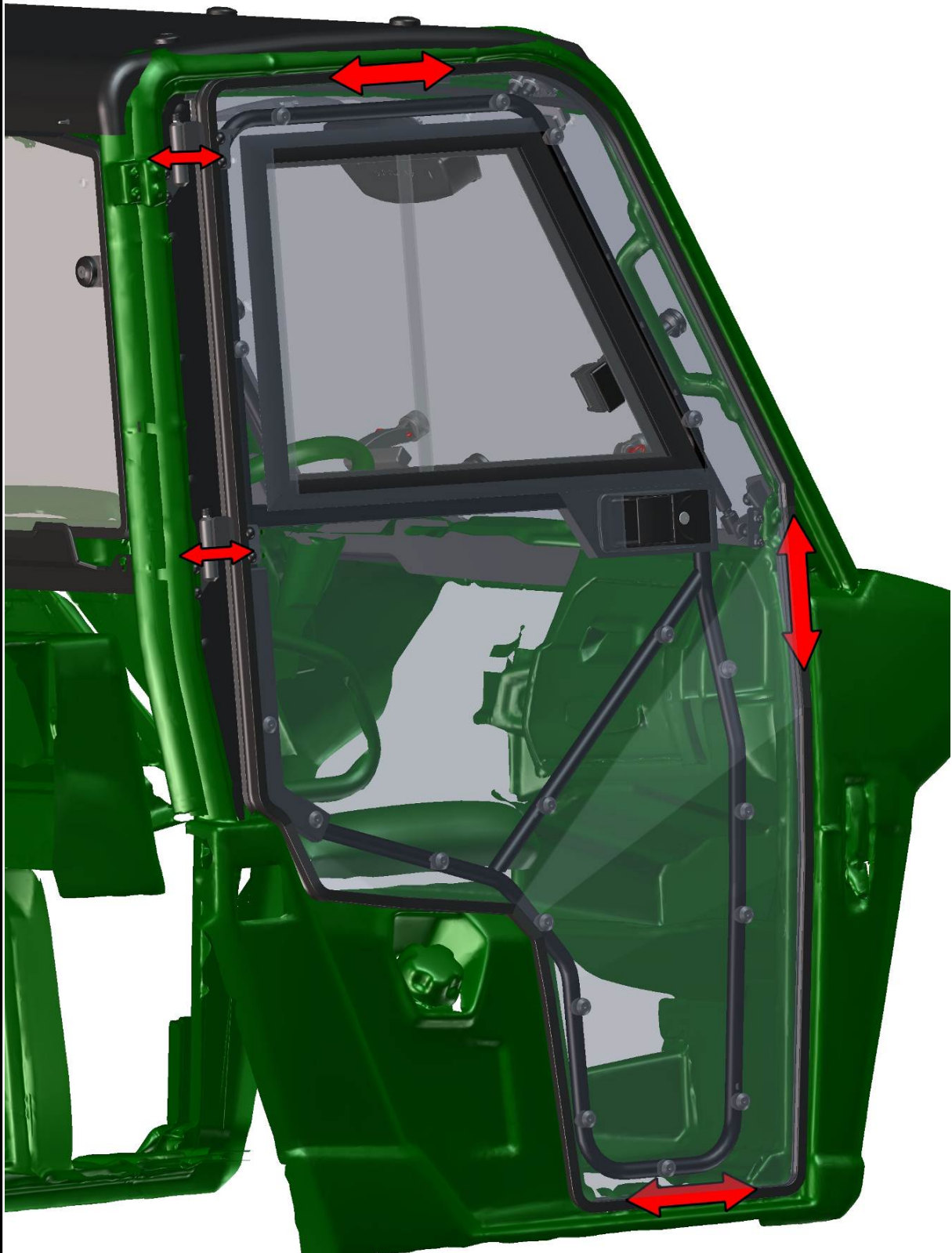

59

FOR ALL TECHNICAL QUESTIONS, PLEASE CALL
DFK AMERICA INC.
(630) 324-8585

Place the right door stop frame holder onto the right door stop holder and fix by included screws, washers, nuts and covers. Install the door stop assembly into the right door stop holder. Left and right door stop holders is different don't mistaken.

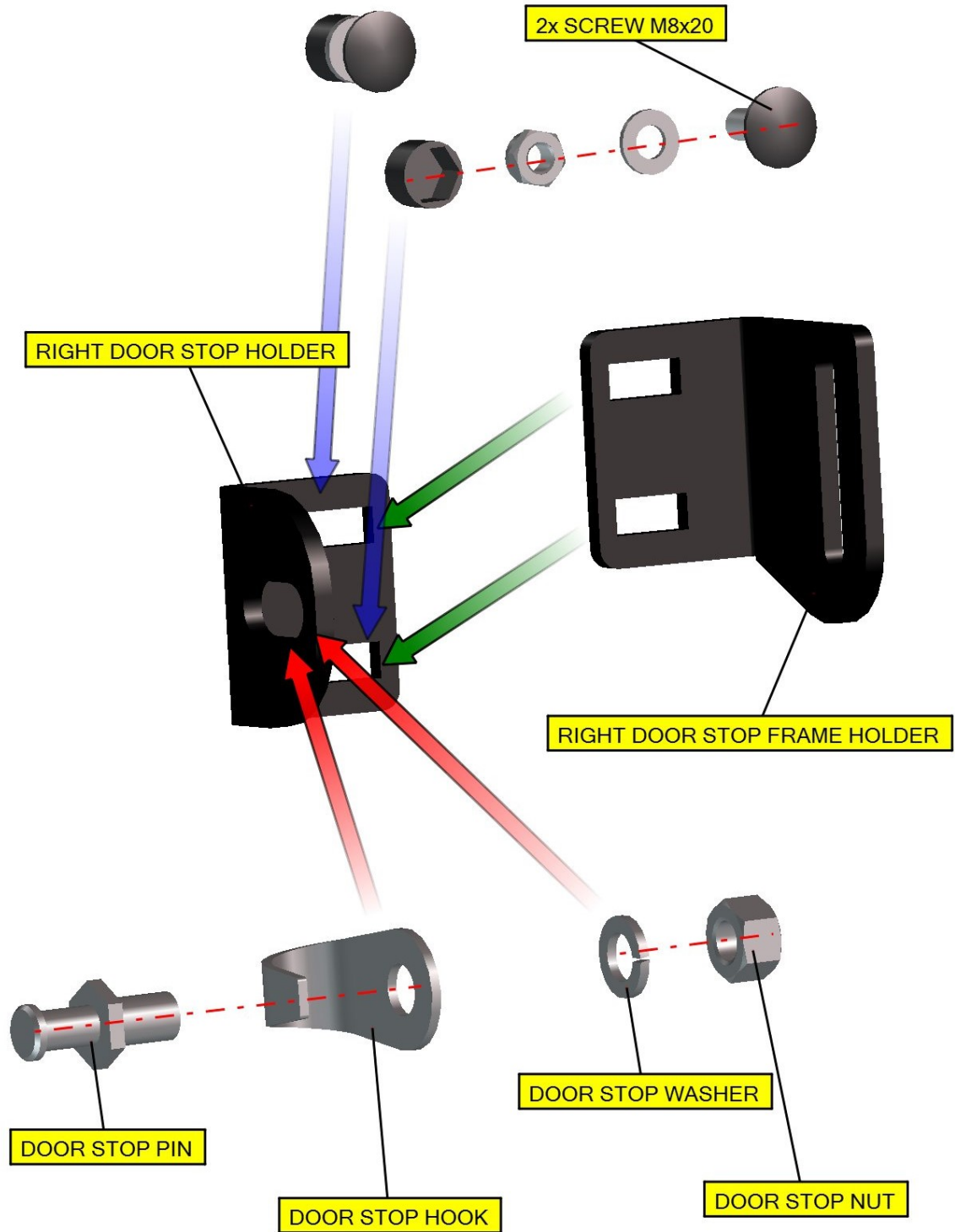

60

Place the right door stop assembly onto UTV roller cage in accordance with the UTV original lath holes (red circle).



61

Fix the right door stop assembly with the UTV roller cage by included screws, washers, nuts and covers.

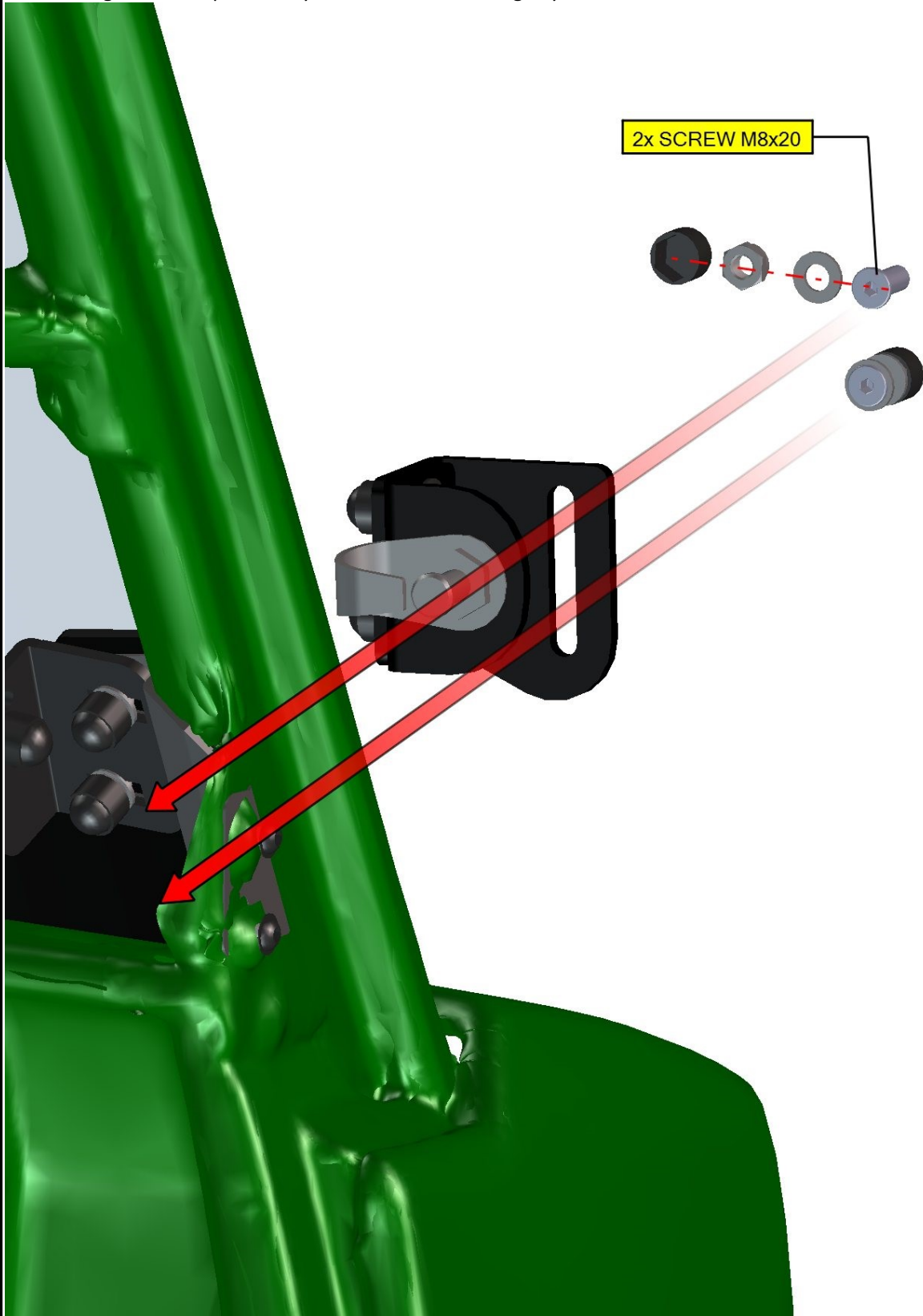

Adjust the right door stop assembly into the best position and tighten screws hard.

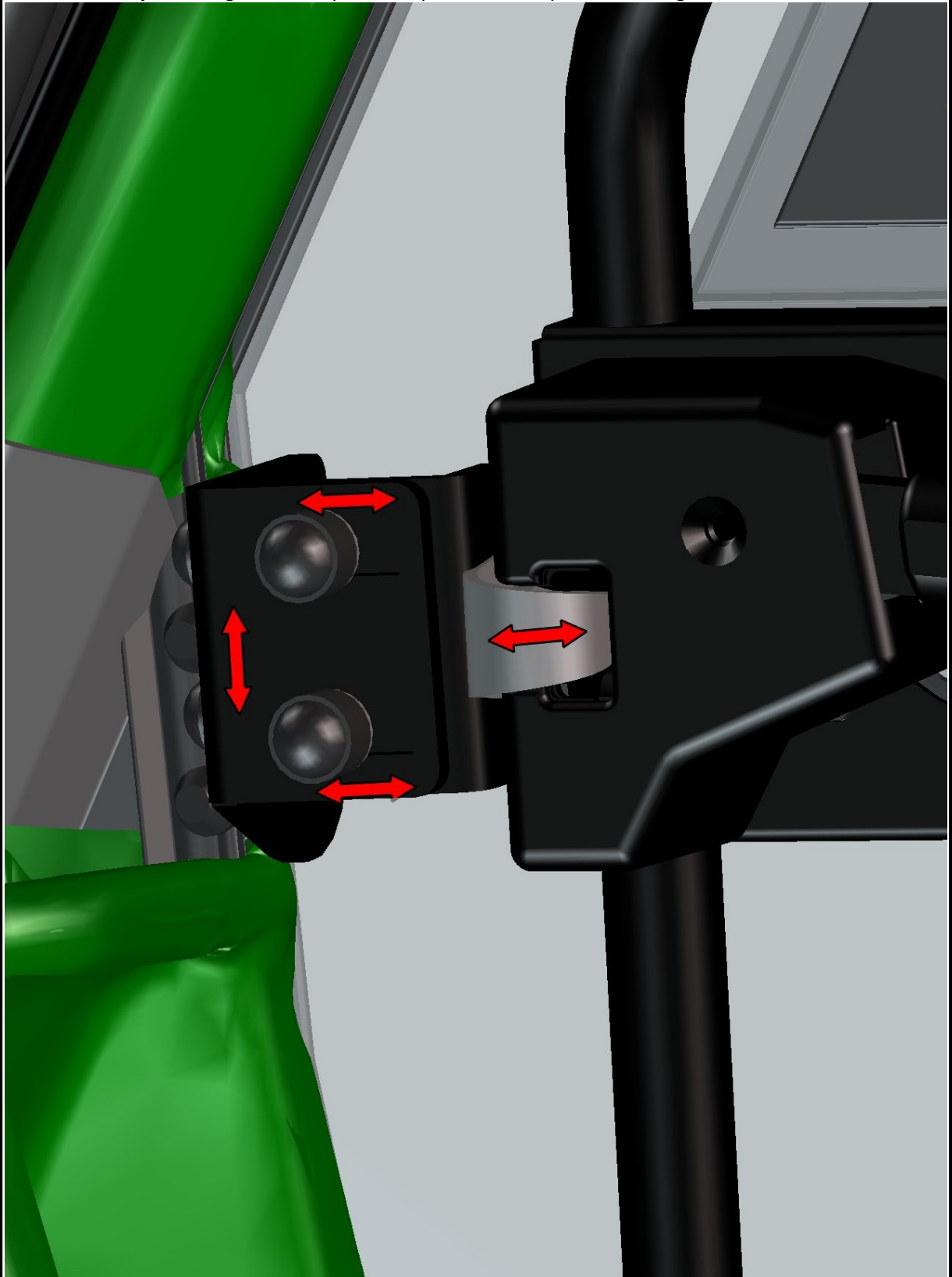

63

FOR ALL TECHNICAL QUESTIONS, PLEASE CALL
DFK AMERICA INC.
(630) 324-8585

Install the gas spring into the gas spring holders and fix by included self-locking nuts M8.

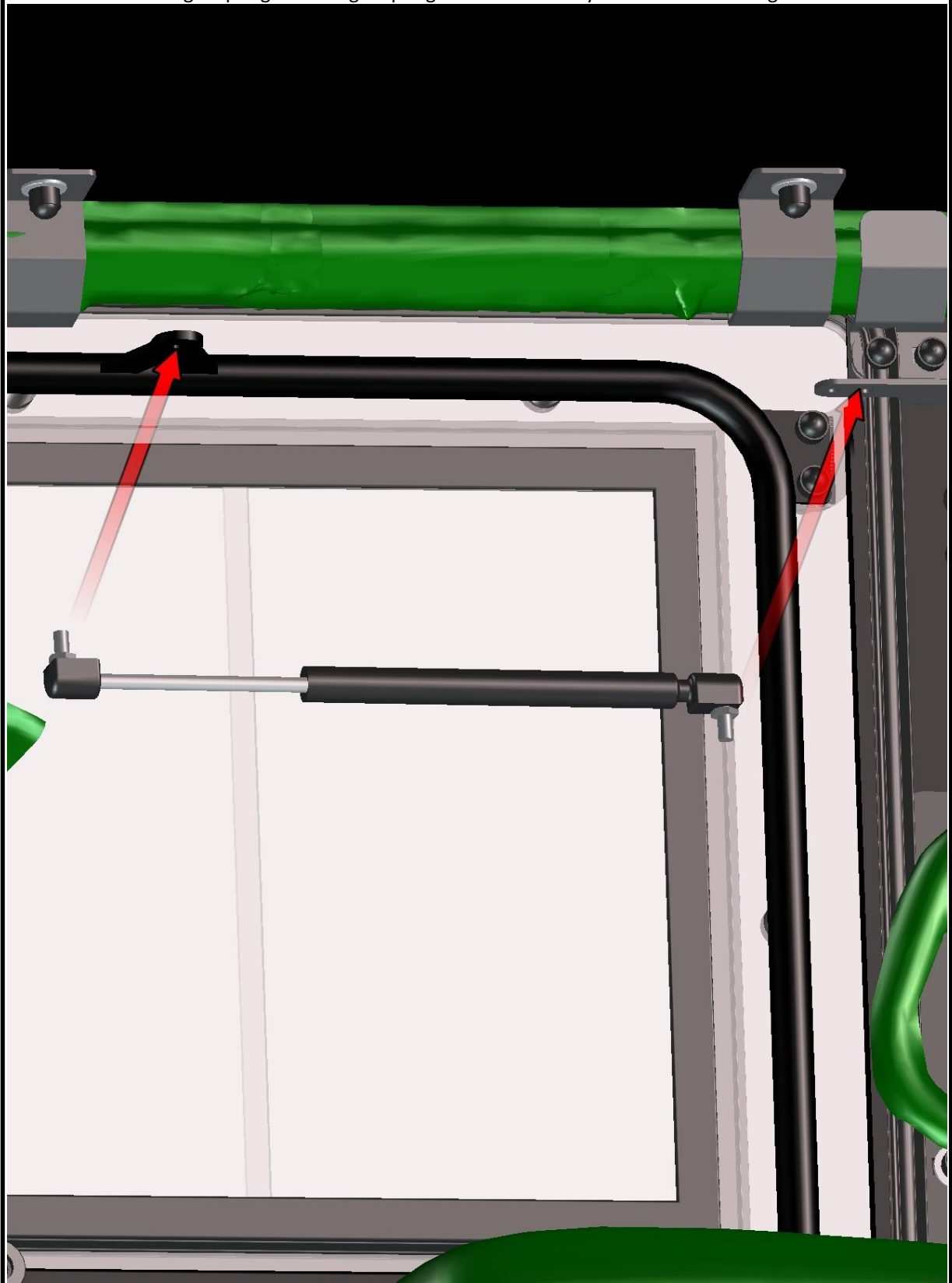

64

FOR ALL TECHNICAL QUESTIONS, PLEASE CALL
DFK AMERICA INC.
(630) 324-8585

Place the right mirror onto the mirror holder and fix by included screws, washers, nuts and covers.

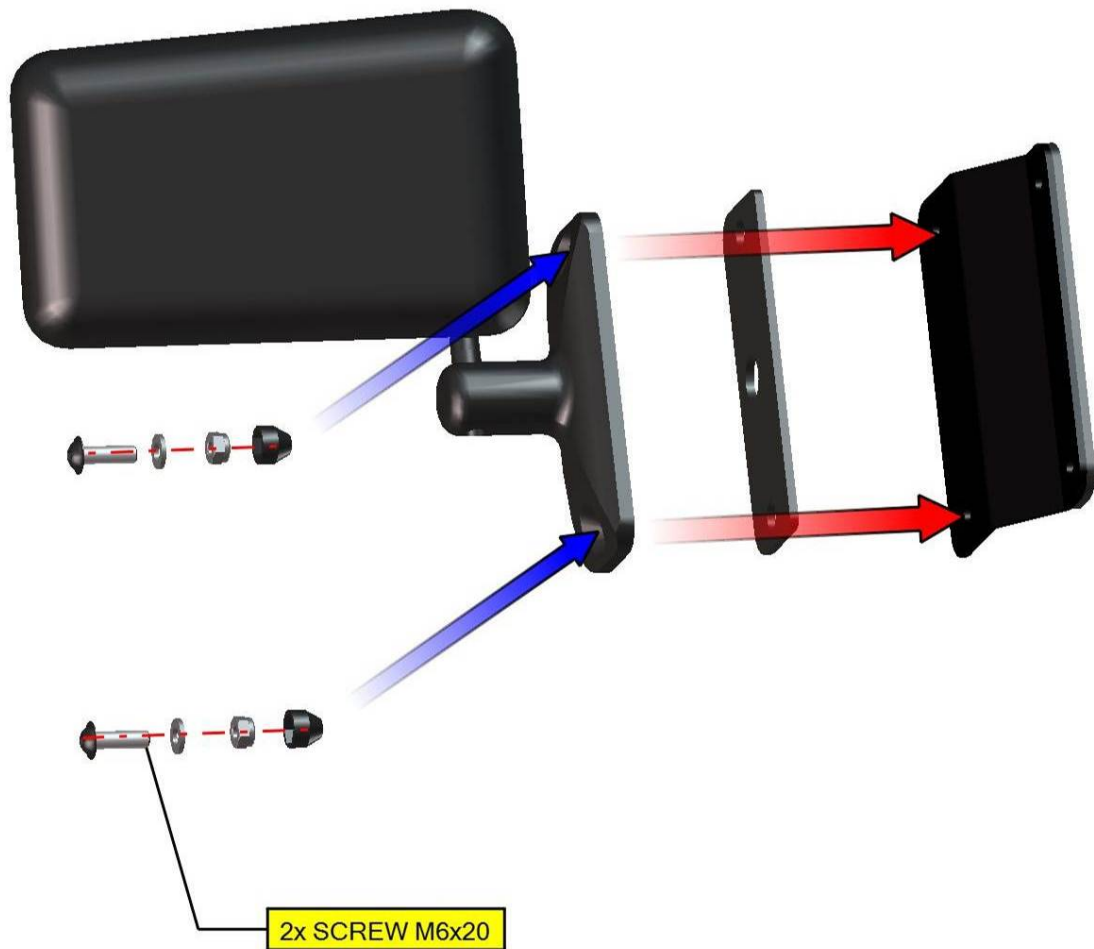

65

Place the right mirror assembly onto the right door frame and fix by included screws and washers.

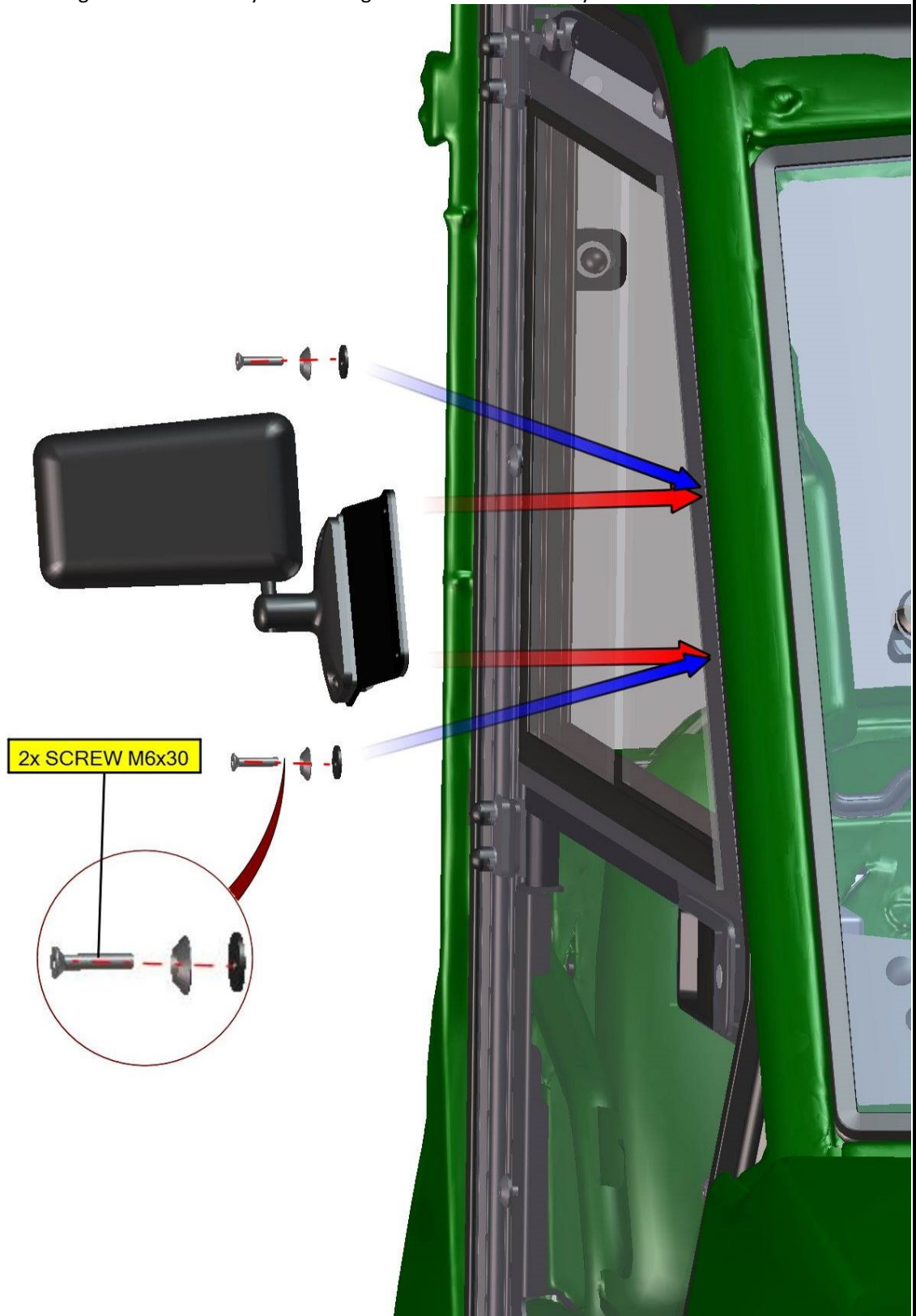

REPEAT PREVIOUS STEPS WITH THE LEFT DOOR.



ELECTROINSTALLATION

Lead the harness branch No.: 1 with the washer hose around the roller cage to the front wiper motor.

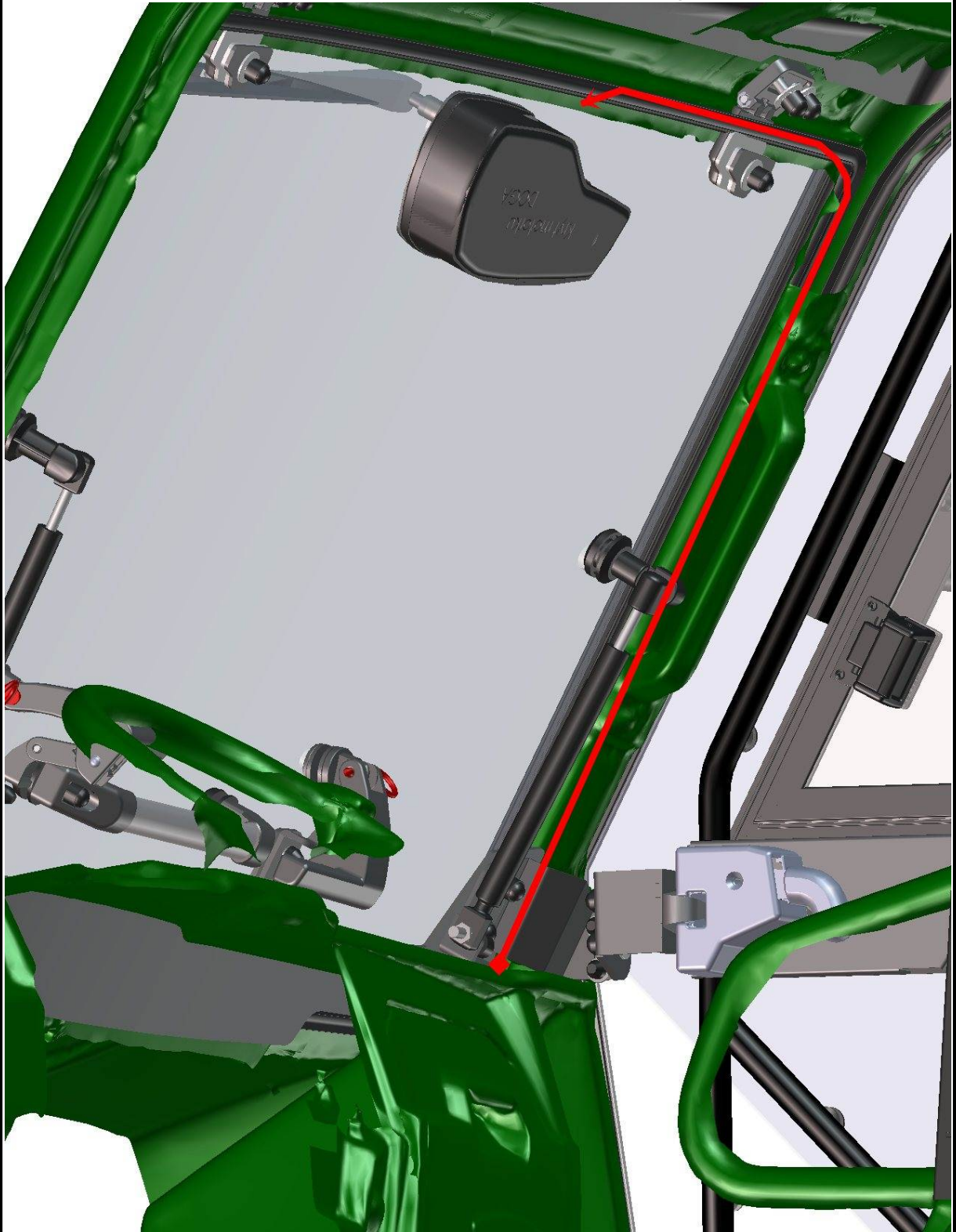

68

FOR ALL TECHNICAL QUESTIONS, PLEASE CALL
DFK AMERICA INC.
(630) 324-8585

Connect the harness branch with the wiper motor connector.

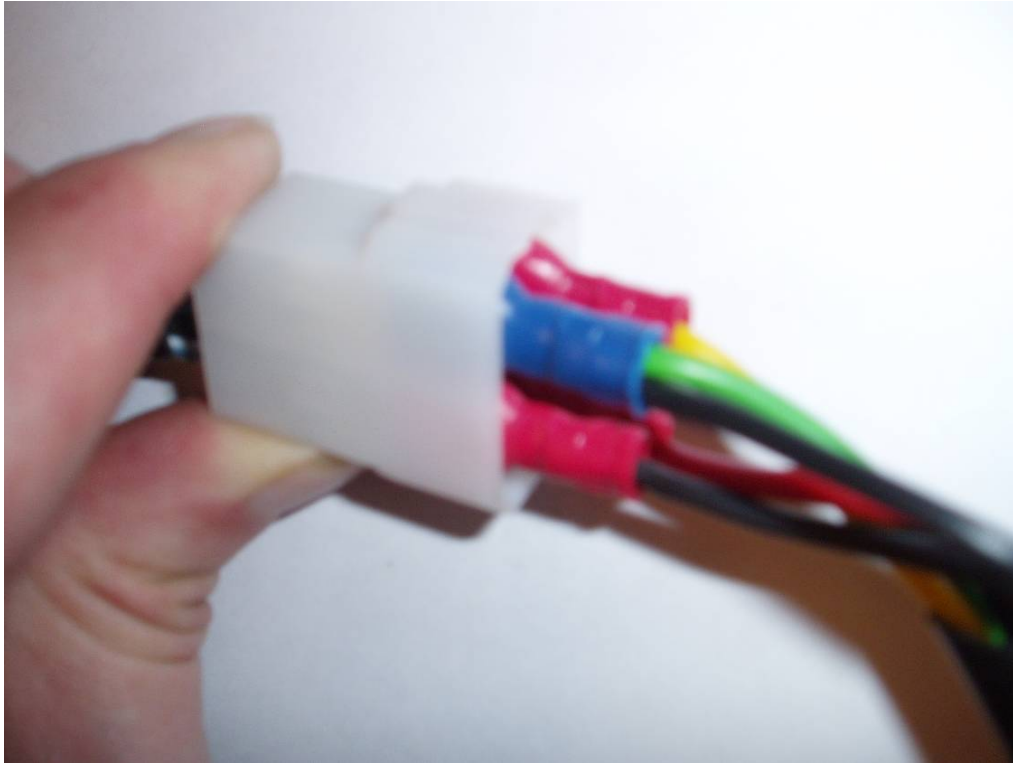

Now you can turn on wiper switch and look on the larger wiper pin.
If you connect all harness connectors correctly, pin is turning. Find the ends of turning and install
the wiper arm on correct position.



FOR ALL TECHNICAL QUESTIONS, PLEASE CALL
DFK AMERICA INC.
(630) 324-8585

Fix the wiper arm with the wiper motor pin by included nut.
Insert plastic holder onto the wiper latch pin in correct position



View onto the installed plastic holder.



Insert the wiper arm hook onto the wiper latch plastic holder and press it into the correct position.



View onto installed wiper arm hook.



Connect the washer hose from the harness with the washer hose from wiper arm by included tube.

