

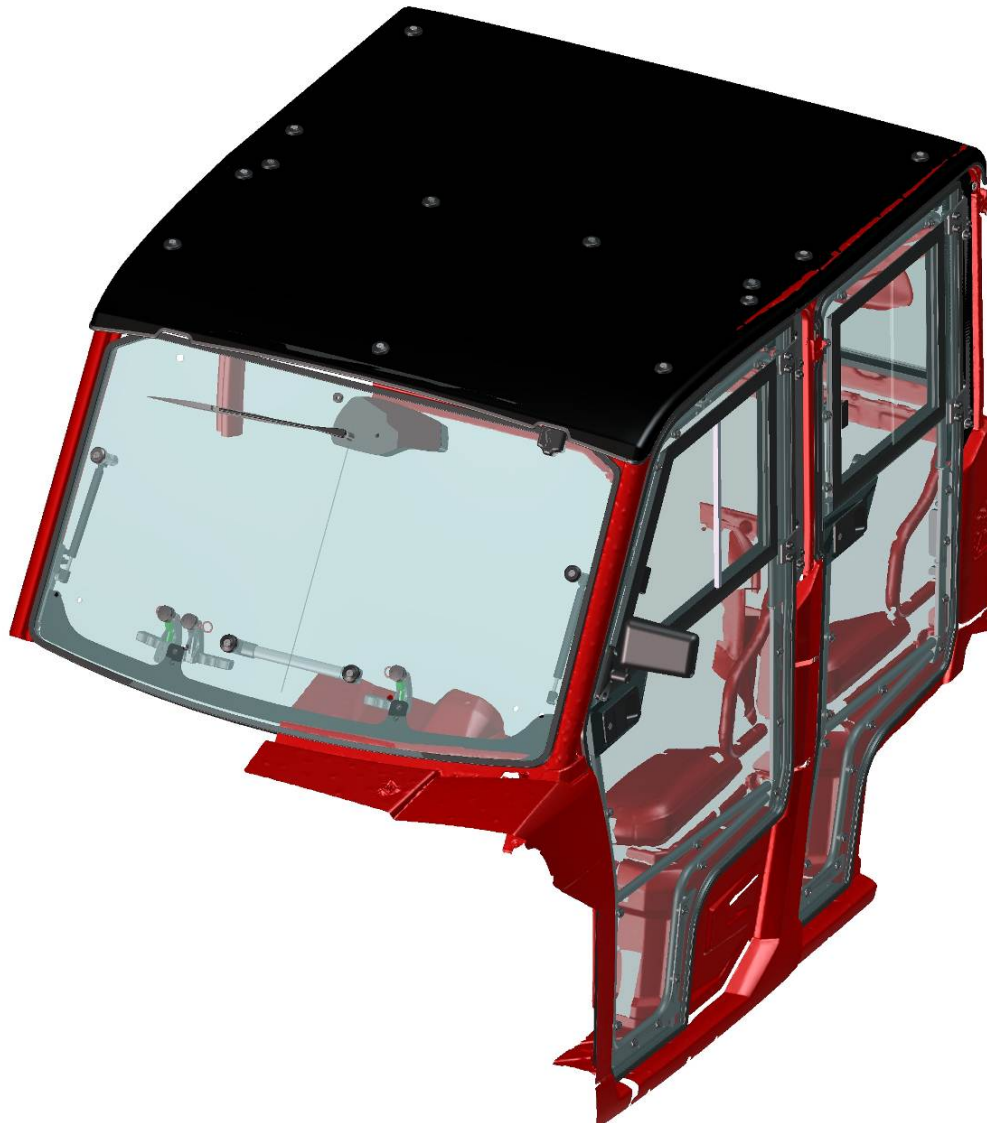

*INSTALLATION INSTRUCTIONS*

**POLARIS**  
**RANGER 900 XP CREW**





## **SAFETY INSTRUCTIONS**

***Warning: Failure to heed all safety and operating instructions and warnings regarding use of this product can result in serious bodily injury.***

### ***READ PROPERLY COMPLETE ASSEMBLY INSTRUCTIONS BEFORE STARTING OF ASSEMBLY***

***Install all parts indicated in assembly instructions. Failure to fully assemble product before use could result in personal injury.***

***Assembly of product requires use of hand or power tools. If you are not experienced in using these types of tools, have product dealer do the install for you.***

***Some parts contain sharp edges, wear protective gloves if necessary.***

***Always keep your assembly area clean, uncluttered and well lit.***

***Keep visitors and children a safe distance away from the assembly area. Visitors should wear the same safety equipment described above.***

***Never operate your UTV with the cab doors open. Failure to properly latch the doors before moving the vehicle could result in serious injury.***

***Dress for safety. DO NOT wear loose clothing, gloves, neckties or jewelry if using power tools to assemble this product.***

***Insert all nut covers after you finish installation.***

***Never drive your UTV with the cab front window in open position. Failure to properly latch/lock front window before driving the vehicle could result in serious injury.***

***Please be careful not to break the plastic washers, if you're tightening screws with plastic washers use max torque of 3.7 foot-pound force (5 Nm)!!!***

***For safety purposes, if the DFK Cab doors are removed, it is mandatory that the OEM Half Doors or Nets are REINSTALLED before operating vehicle.***

---

FOR ALL TECHNICAL QUESTIONS, PLEASE CALL

DFK AMERICA INC.  
(630) 324-8585

## **MAINTENANCE AND CLEANING**

*To clean polycarbonate surface use soapy water solution or other subtle means.*

*Dirt and dust wash by gently water stream and swipe only with wet or damp means in the direction from top to bottom.*

*The recommended frequency of cleaning of polycarbonate part is about 1 time per month or according to the actual degree of pollution.*

*Do not use detergents that could scratch the surface plates.  
(abrasives, harsh fabrics, etc.)*

*Do not use solvents or alkaline detergents or cleaners with ammonia  
(ammonium hydroxide).*

*Do not remove the impurities from the surface of the razor blades or other sharp items.*

*Do not clean cabin when the polycarbonate plates are heated by the sun.*

*Do not use the squeegee, it could be scratched surface plates.*

*Do not clean the water current strength greater than 50 bar (WAP)*

*The manufacturer is not responsible for scratching the surface in case of failure to comply with the above instructions.*

*All bolted connections of cab must be by user at regular intervals checked and tightened.*

**TOOLS NEEDED**

Not included

		
<p><b>Ratchet handle</b></p>	<p><b>Socket beg 17 mm</b> <b>(0,67 in)</b></p>	<p><b>Socket beg 13 mm</b> <b>(0,51 in)</b></p>
 <p><i>For tightening straps</i></p>		
<p><b>Socket beg 8 mm</b> <b>(0,31 in)</b></p>	<p><b>Metric wrench 13mm,</b> <b>17mm</b></p>	<p><b>Utility knife</b></p>
		
<p><b>Hex key 5mm, 6 mm and</b> <b>8mm</b></p>	<p><b>Hole saw 56 mm</b> <b>(2,2 in)</b></p>	<p><b>Hole saw 76 mm</b> <b>(3 in)</b></p>

<p><b>Drill <math>\phi</math> 2,5-4mm</b> <b>( 0,1- 0,16 in)</b></p>	<p><b>Drill <math>\phi</math> 8mm</b> <b>(0,31-0,33 in)</b></p>	<p><b>Drill <math>\phi</math> 12 mm</b> <b>(0,5 in)</b></p>
<p><b>Drill <math>\phi</math> 21mm</b> <b>(0,83 in)</b></p>		

**PREPARATION FOR INSTALLATION:**

Uninstall all additional systems from the roller cages (work lights, rear mirrors, drink holders etc.)

**ELECTROINSTALLATION-WIPER+WASHER step 1.**

**Parts needed**

Included

Washer tube



Switch wiper/washer/off



Harness and washer tank



Wiper harness



Washer tank has been placed under the front dashboard cover.  
Uninstall the upper dashboard cover from the UTV carefully.



Take out the front dashboard cover and uninstall original screw (in red circle) from the UTV's plastic front wall and install the washer tank holder.



Connect the harness branch No.: 3 with washer motor and slide the washer tank onto the washer tank holder. Lead harness (red arrow) from the washer through the hole to the inner place in the dashboard.



FOR ALL TECHNICAL QUESTIONS, PLEASE CALL  
DFK AMERICA INC.  
(630) 324-8585



Lead the harness branch No.: 1 (red arrow) to the right front roller cage.



Drill hole (red circle)  $\varnothing$  21mm (0,83in) into the unmounted dashboard cover near the right roller cage and stretch the harness branch through the hole.

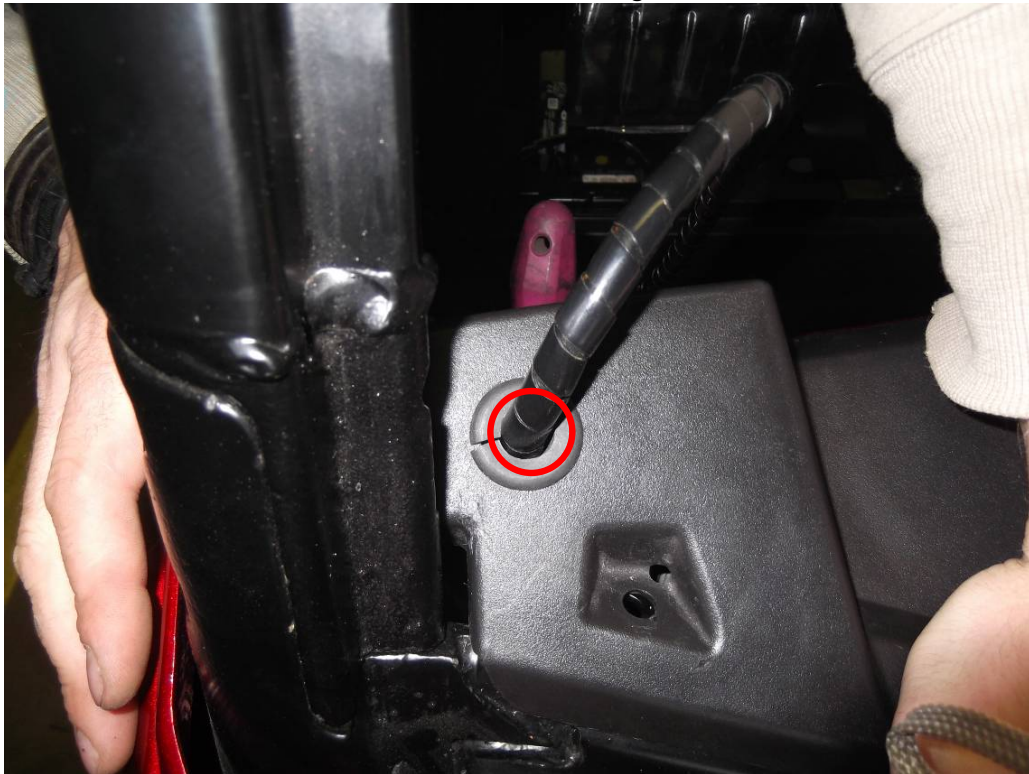

FOR ALL TECHNICAL QUESTIONS, PLEASE CALL  
DFK AMERICA INC.  
(630) 324-8585

Uninstall the central panel from the dashboard and lead the harness branch.: 2 from the harness to the central panel.



Take out the switch blind from the central panel. Pull the harness branch No.: 2 through the hole and connect the harness (red arrow) with the switch wiper/washer.

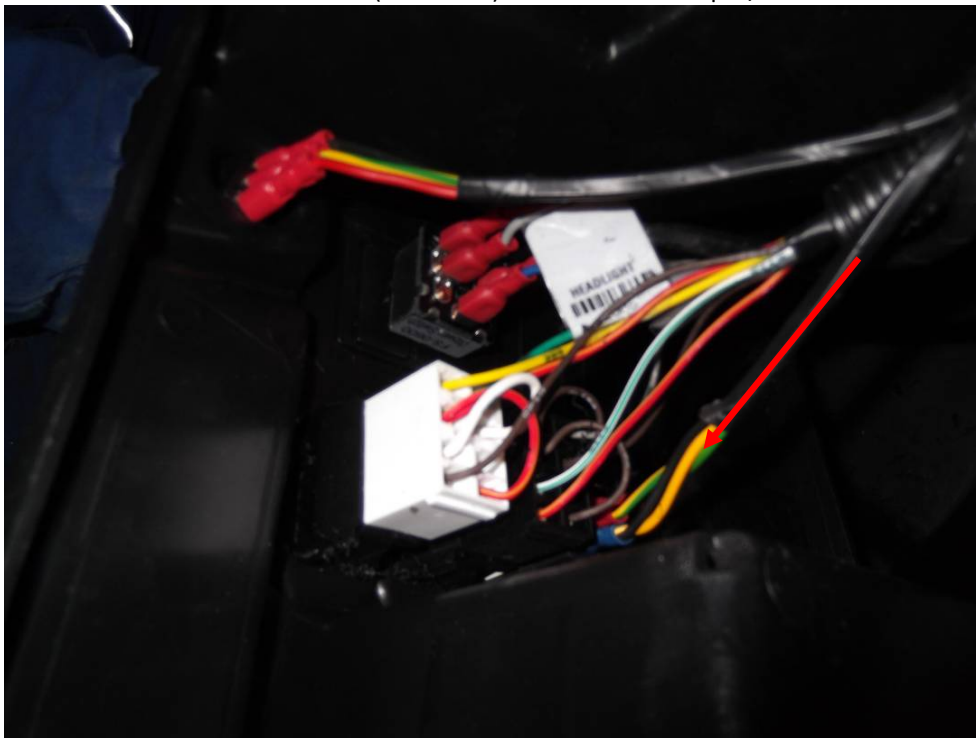

SEE NEXT PAGE





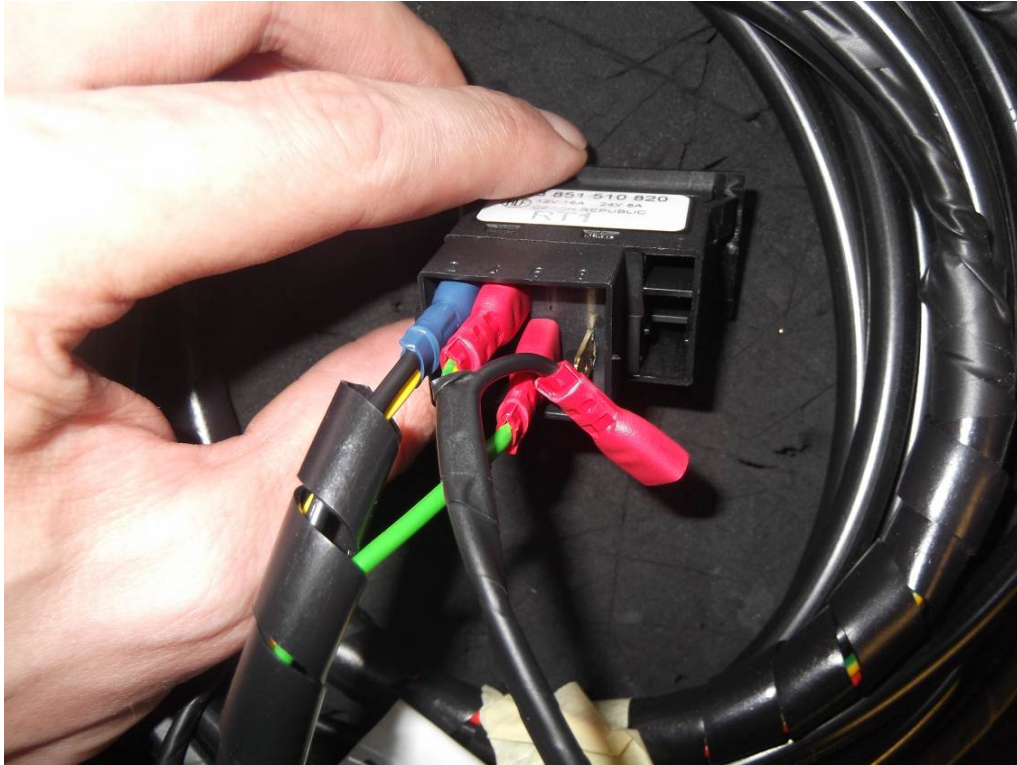

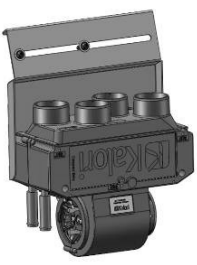

FOR ALL TECHNICAL QUESTIONS, PLEASE CALL  
DFK AMERICA INC.  
(630) 324-8585

Detail view of connections.

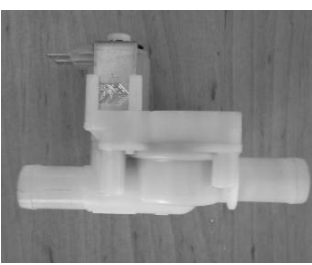

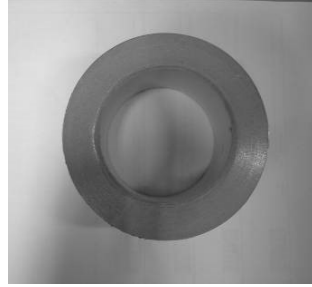

***Fill the washer liquide to the washer tank before first usage.***

**ELECTROINSTALLATION – HEATER**  
*Parts needed (included)*

		
<p><b>Heater with cover</b></p>	<p><b>Bleeding valve</b></p>	<p><b>Electric vent</b></p>
		
<p><b>Tightening straps</b>  <b>Smaller, bigger and large</b></p>	<p><b>Air vent smaller</b></p>	<p><b>Air vent bigger</b></p>
		
<p><b>Hot air hose</b></p>	<p><b>AL tape</b></p>	<p><b>Y coupling</b></p>

		
<b>Y coupling</b>	<b>El. Vent switch</b>	<b>Heater switch assembly</b>

		
<b>Heater harness</b>	<b>Hot water hose</b>	



FOR ALL TECHNICAL QUESTIONS, PLEASE CALL  
 DFK AMERICA INC.  
 (630) 324-8585

**IMPORTANT**

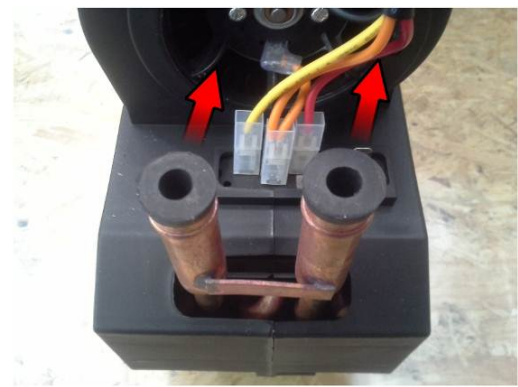
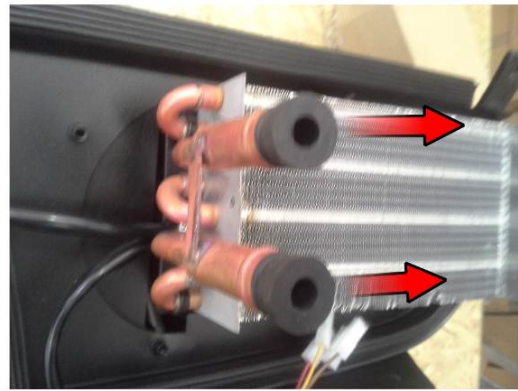
IT IS ABSOLUTELY NECESSARY TO TAKE OUT THE RUBBER PLUGS FROM THE HEATER TUBES!!!

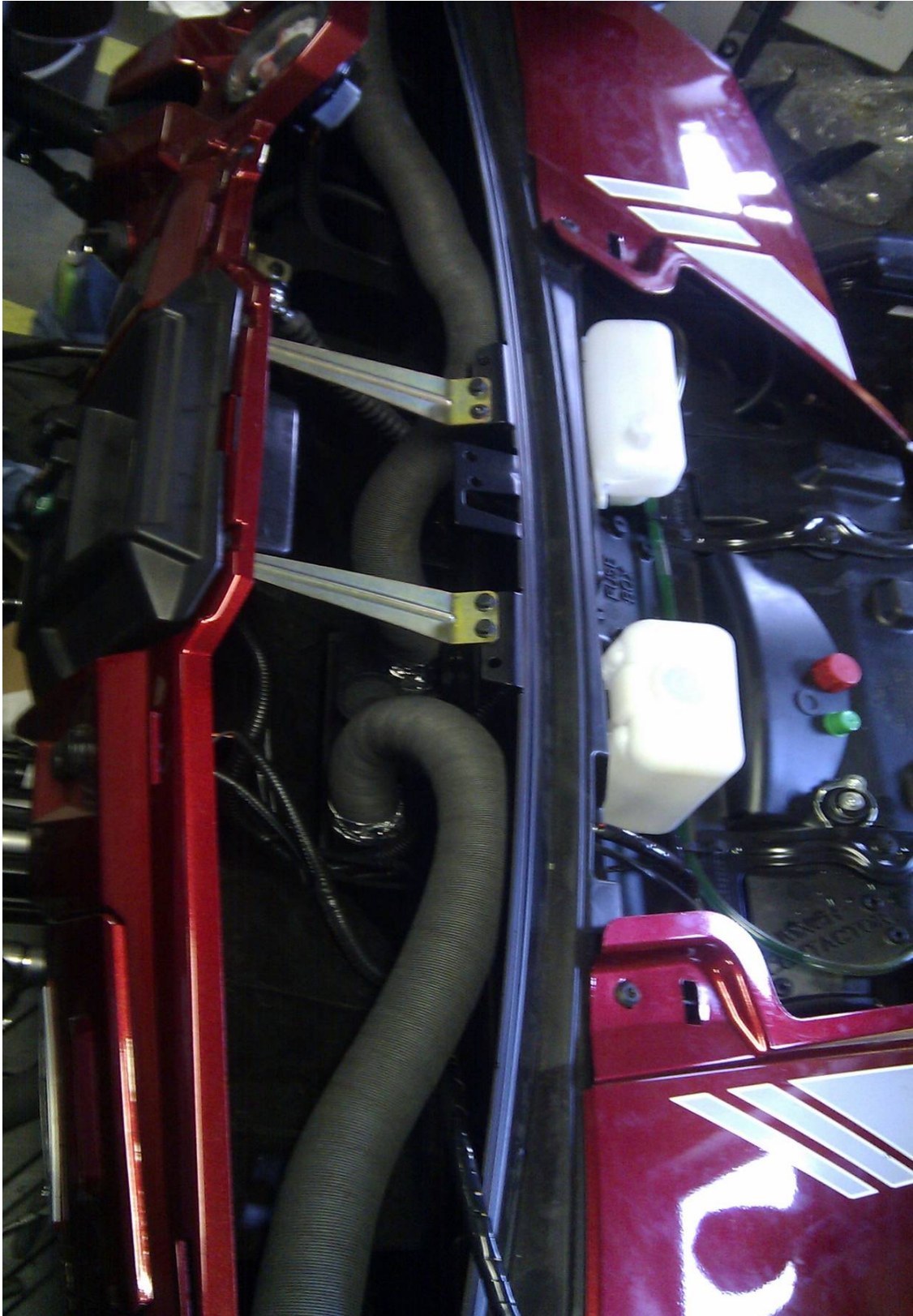

The heater has been installed in the middle inner place under dashboard.



FOR ALL TECHNICAL QUESTIONS, PLEASE CALL  
DFK AMERICA INC.  
(630) 324-8585

Uninstall the central tunnel cover from UTV's floor.



Secure original hot water hose (with red line) by pliers or clamps.



FOR ALL TECHNICAL QUESTIONS, PLEASE CALL  
DFK AMERICA INC.  
(630) 324-8585



Cut the hose between pliers and insert tightening straps at loose ends. Install the small "Y" coupling into the original hose and into the heater hose (included). Tighten all (3) straps hard and lead the water hose from the engine to the central floor tunnel. It is necessary to keep the heater hose (red arrow) in direction of down and forward. **Side view.**



Lead the water hose (red arrow) through the floor tunnel.

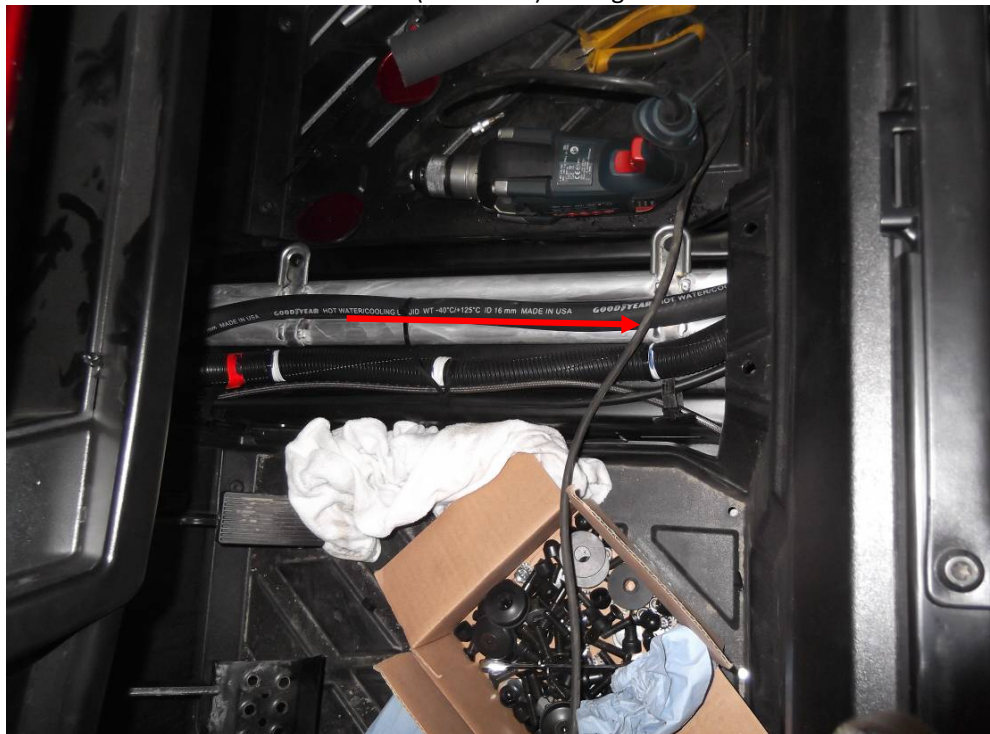

FOR ALL TECHNICAL QUESTIONS, PLEASE CALL  
DFK AMERICA INC.  
(630) 324-8585

Cut the water hose (with red line) to correct length, be careful not to cut that hose too short.



Install the short hose and remain of the hose to the heater tubes. Fix these hoses with the heater tubes by tightening straps and tighten these straps very hard. Insert the tightening strap onto the shorter hose and install electromagnetic valve **in same orientation like in picture**. Tighten that strap very hard.



FOR ALL TECHNICAL QUESTIONS, PLEASE CALL  
DFK AMERICA INC.  
(630) 324-8585

Uninstall original screws from UTV's plastic wall.



Connect harness branch No.: 3 with the heater connector. Detail view.

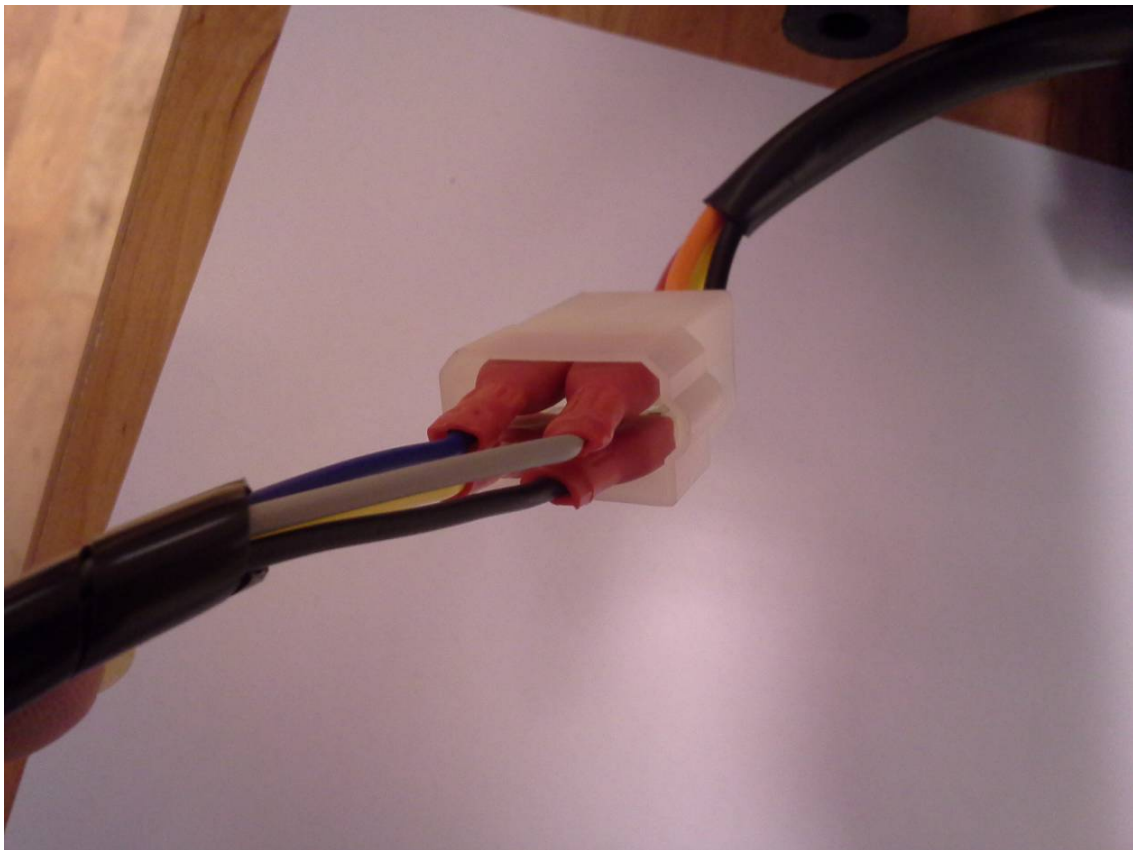

FOR ALL TECHNICAL QUESTIONS, PLEASE CALL  
DFK AMERICA INC.  
(630) 324-8585

Connect the harness branch No.: 4 with the electromagnetic valve. Detail view.

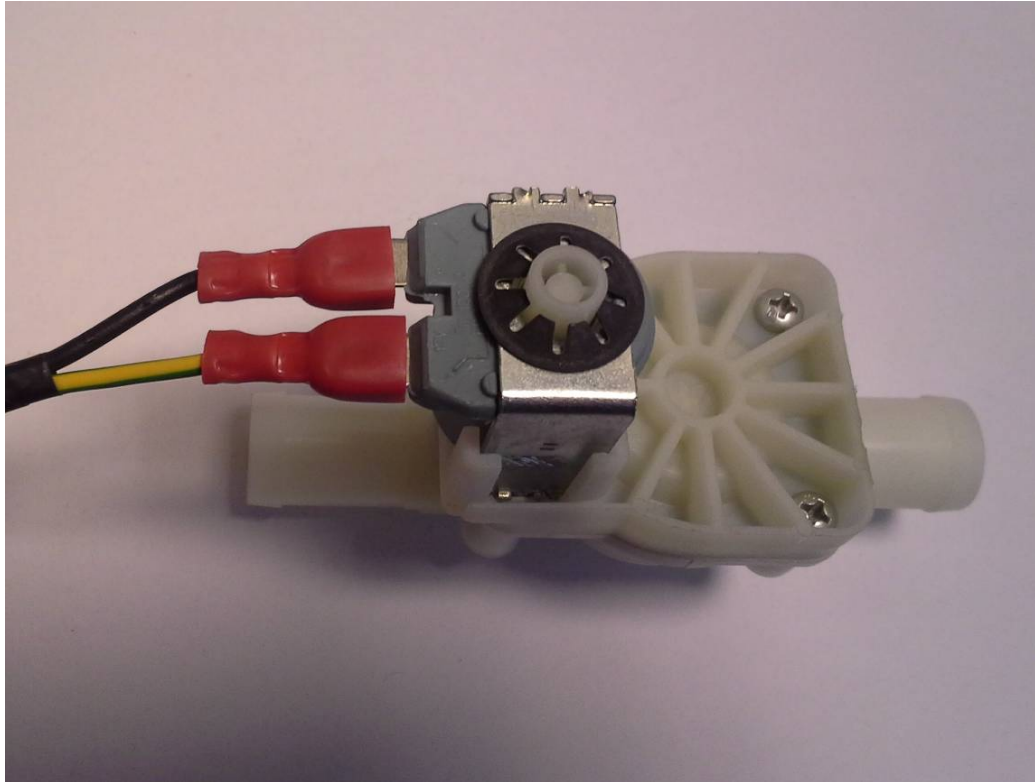

Place the heater with holder onto the UTV inner wall and adjust to correct position.



FOR ALL TECHNICAL QUESTIONS, PLEASE CALL  
DFK AMERICA INC.  
(630) 324-8585

Fix the heater holder with the UTV wall by included screws M6x30 and washers (red circles).

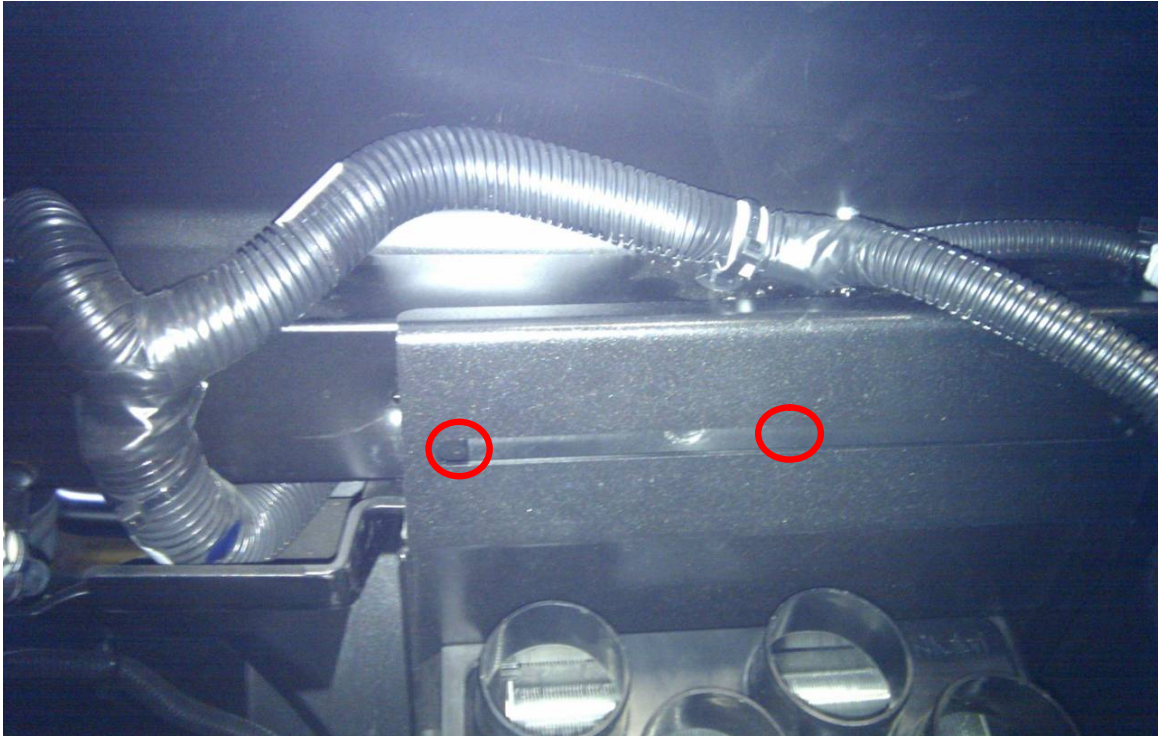

Insert the tightening strap onto the hose from engine (red arrow) and connect that hose with electromagnetic vent. Tighten strap very hard. Lead the water hose (violet arrows) from heater to the front left wheel.



FOR ALL TECHNICAL QUESTIONS, PLEASE CALL  
DFK AMERICA INC.  
(630) 324-8585

Secure vertical original hot water hose (with red line) near the left wheel by pliers or clamps from page No.: 12. Cut the vertical hose between the pliers and insert the tightening straps onto the hose.

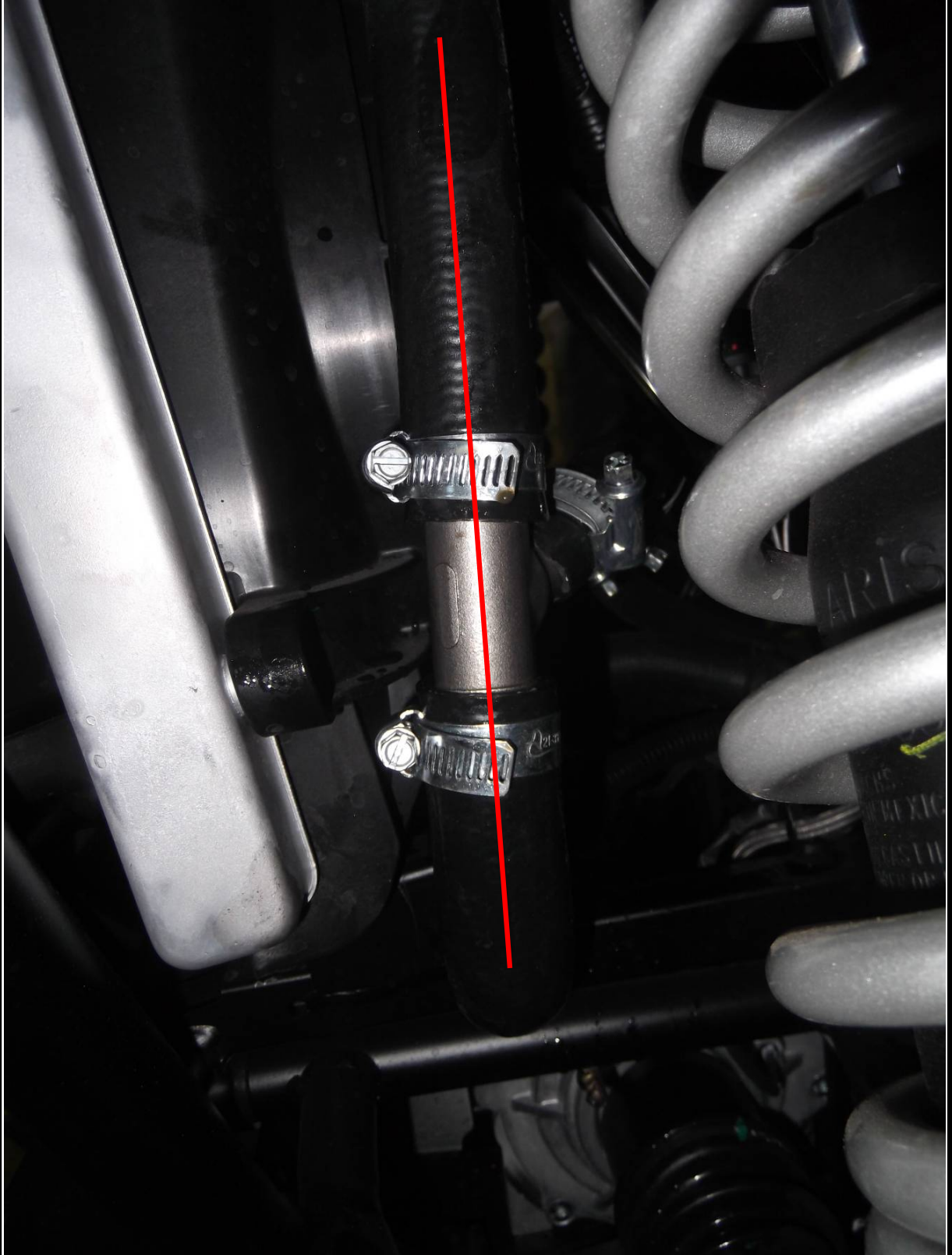

22

FOR ALL TECHNICAL QUESTIONS, PLEASE CALL  
DFK AMERICA INC.  
(630) 324-8585

Insert the "Y" couple into the original hole. Insert the tightening strap onto the hose from heater and insert that hose onto the "Y" couple. Tighten all straps very hard and take out the pliers.



23

FOR ALL TECHNICAL QUESTIONS, PLEASE CALL  
DFK AMERICA INC.  
(630) 324-8585

Cut the heater hose near "Y" coupling from previous page and insert the tightening straps. Install the air vent valve into the hose and fix these by straps. Tighten straps very hard.



Drill 1 hole  $\varnothing$  11,5-14mm (0,45-0,55 in) and 2 holes  $\varnothing$  2,5-4 mm ( 0,1- 0,16 in) into the dashboard in accordance with the ventilator switch base.





Lead the harness branches No.:1 and 2 from the heater to the UTV switch panel.  
Connect the heater switch body with the harness branch No.:1. Detail view.

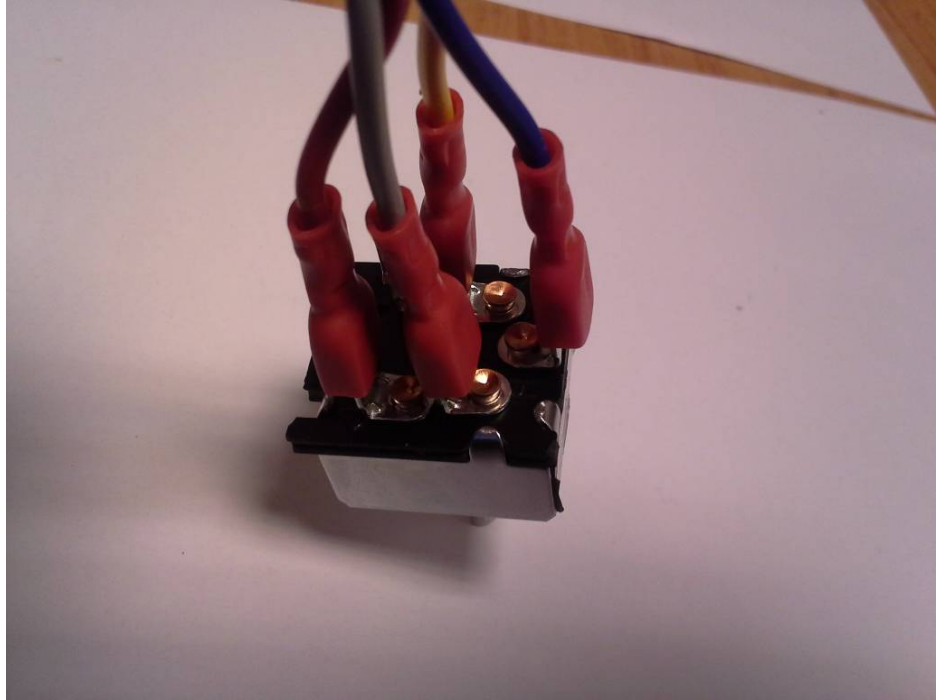

Insert the switch body with the harness and with the serrated-lock washer into the prepared hole from page No.: 20(upper picture) from inside. Place the switch base onto the dashboard and onto the pin of the switch body.



Fix the switch with the switch base to dashboard by nut.



And place the plastic had onto the switch pin.  
View onto installed heater switch.



FOR ALL TECHNICAL QUESTIONS, PLEASE CALL  
DFK AMERICA INC.  
(630) 324-8585

Drill hole  $\varnothing$  21 mm (red circle) for electromagnetic vent switch.



Pull the harness branch No.: 2 through the hole from previous page (bottom picture) and connect the branch with the switch. Detail of connection.

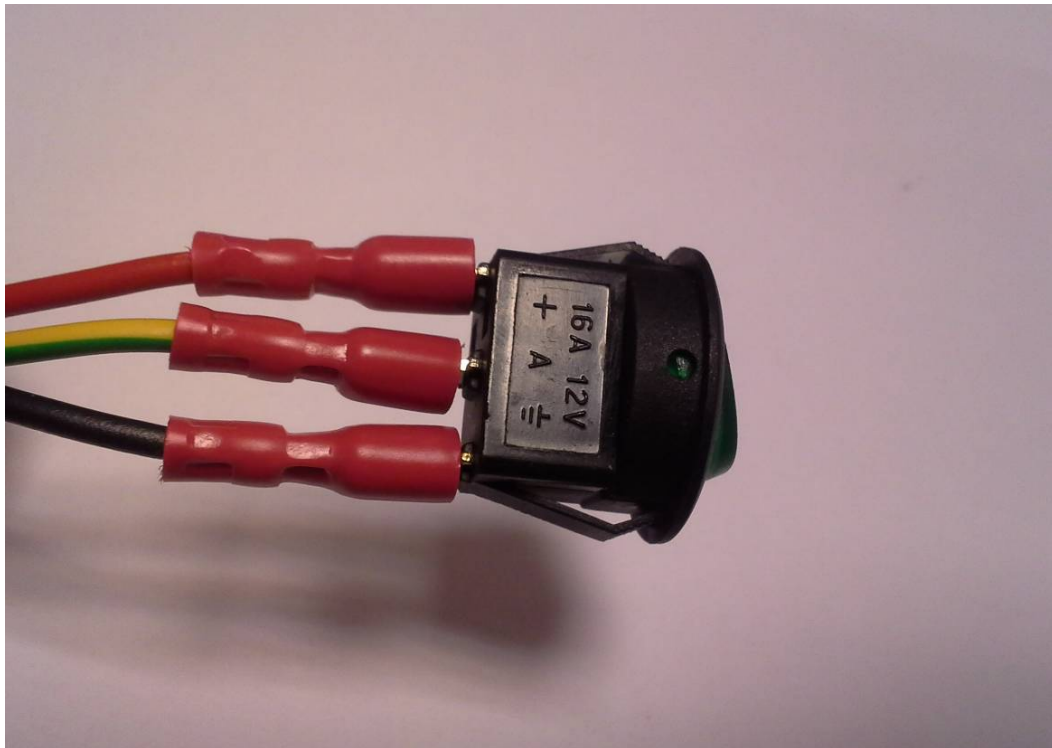

FOR ALL TECHNICAL QUESTIONS, PLEASE CALL  
DFK AMERICA INC.  
(630) 324-8585

Inner view onto connected switches.



28

Lead the harness branch No.: 5 heater and No.: 4 wiper washer from harness to the front space.

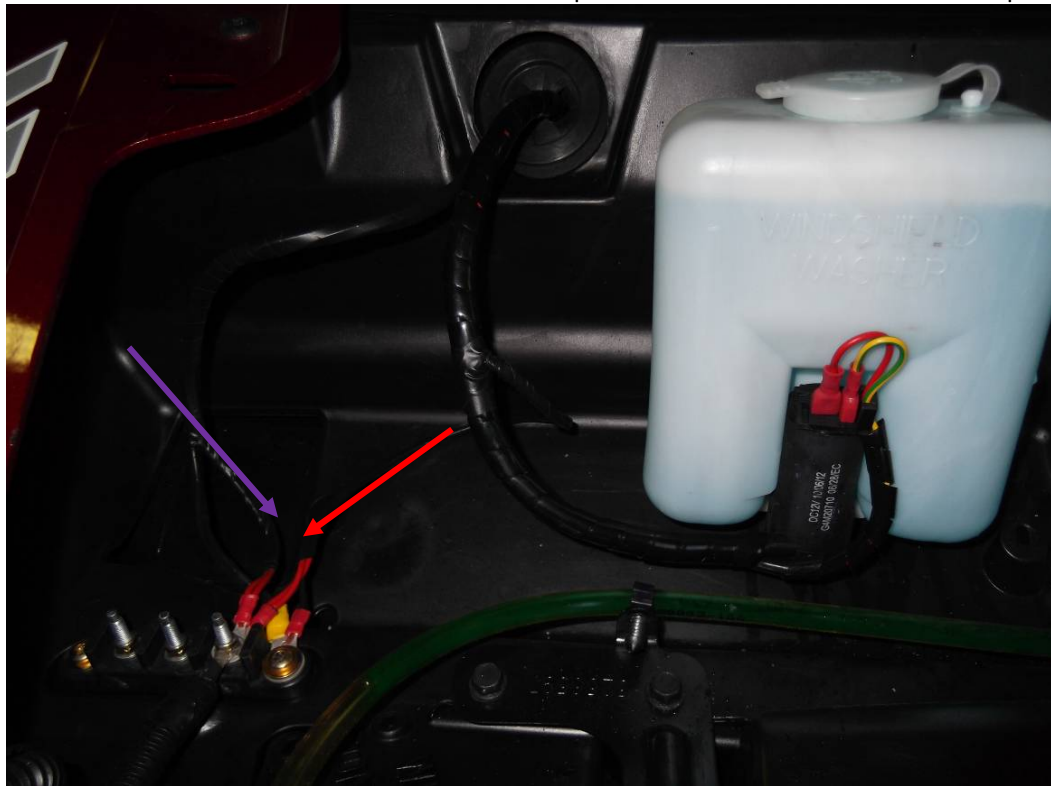

FOR ALL TECHNICAL QUESTIONS, PLEASE CALL  
DFK AMERICA INC.  
(630) 324-8585

Connect the branches with the UTV' electroinstallation. Detail of connections.

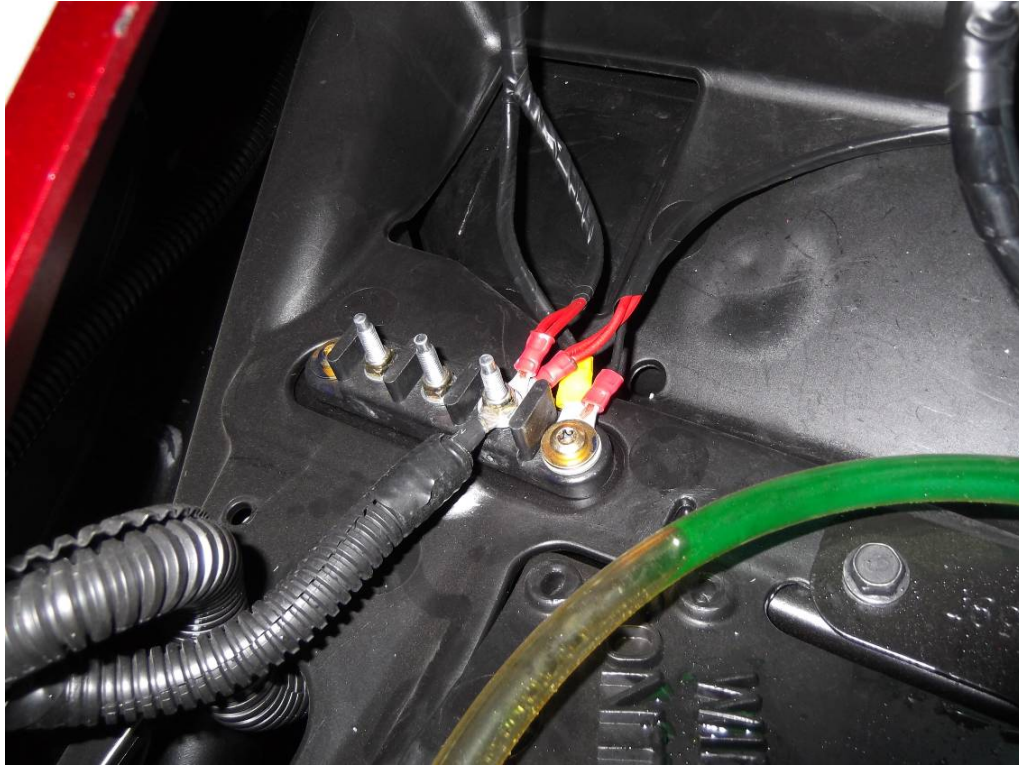

Make marks onto the dashboard and drill hole  $\varnothing 8$  mm (0,31-0,33 in) into the marks center.

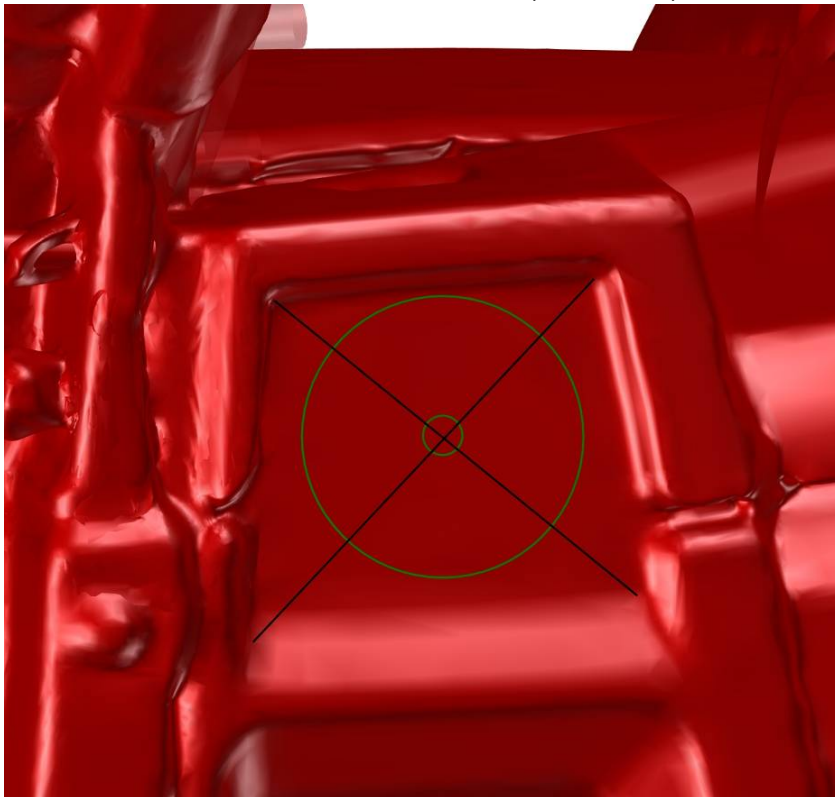

FOR ALL TECHNICAL QUESTIONS, PLEASE CALL  
DFK AMERICA INC.  
(630) 324-8585

Cut the holes  $\varnothing 56\text{mm}$  (2,2 in) into the dashboard, use hole from previous step like pivot.



Cut the edge carefully from inner side. Repeat these steps on right dashboard side. Insert the air hose into the heater air tube and fix by included "AL" self glued tape.

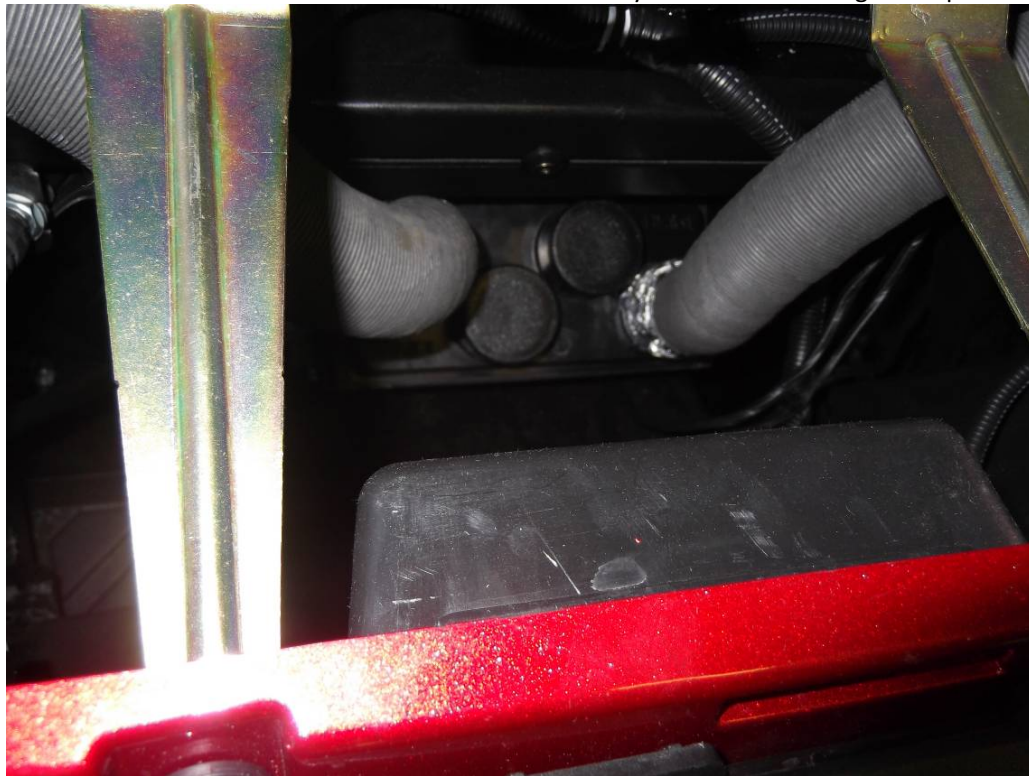

FOR ALL TECHNICAL QUESTIONS, PLEASE CALL  
DFK AMERICA INC.  
(630) 324-8585

Lead air hoses to the roller cage. Insert air vent smaller into the hole. Insert tightening strap onto the air hose and insert the air hose onto the air vent smaller. Tighten strap hard.



Place the template onto the dashboard and adjust to best position.

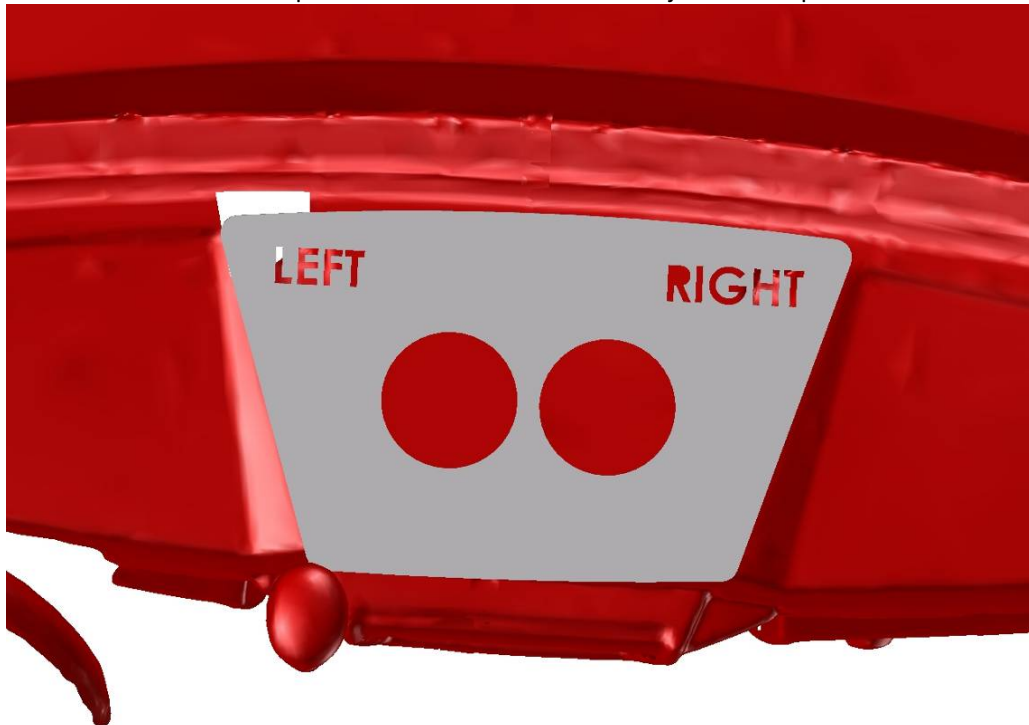

Make marks in accordance with the template and cut the holes  $\varnothing 76\text{mm}$  (3 in) into the mark's centers.



Cut the hole's edges from inner side.

Insert the air hoses into the heater air tube and fix by AL selfglued tape. Insert air vent straight into the holes from previous page and insert the air hose onto the air vent. Fix the hose with the vents by tightening straps and tighten hard. Place the dashboard cover to correct position and fix that by original screws.

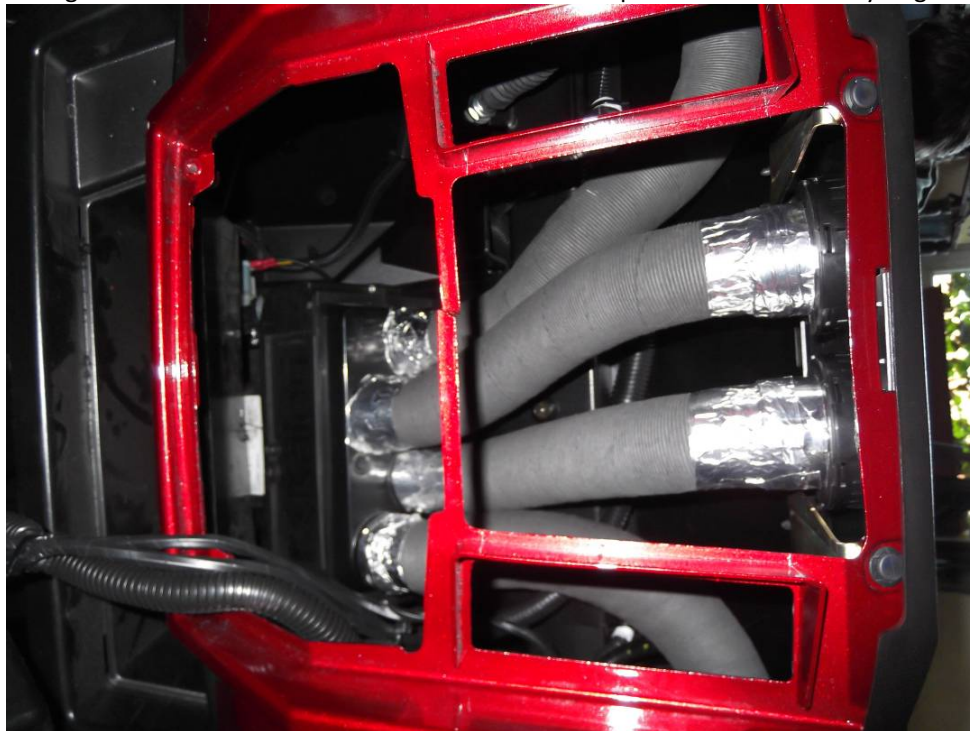



Stick the seal (black hide line) onto the UTV switch panel from inner side to upper edges and install panel back to position.



Cut the hole for hose into the central floor tunnel cover and instal cover back to position.



FOR ALL TECHNICAL QUESTIONS, PLEASE CALL  
DFK AMERICA INC.  
(630) 324-8585

***It is absolutely necessary to bleed the air out of the UTV's engine cooling system. Incomplete bleeding of cooling system can result in engine damage. If you don't have sufficient experience with this process, we strongly recommend professional service technician assistance. We are not responsible for damages when cooling system bled incompletely. Please note that additional heater system will absorb more than 2 liters of coolant fluid.***

- 1. Important: After the heater system installed check the system for leaks. Turn on the electric vent switch and confirm that the engine is cold. Start the engine, open bleeding valve and wait until engine warms up. Important: Always check engine temperature – if it overheats turn off engine.***
- 2. To achieve engine operating temperature depress the accelerator to increase the engine RPM. This will increase the pressure and flow of the water pump forcing more coolant through the heater. After operating temperature reached turn off engine and open it. Trapped air should come out from heater system throughout bleeding valve. Repeat this procedure until heater/cooling system is completely bled out.***

***The DFK Cab heater, like the heater in a car, generates heat from the vehicle's engine.***

***In nearly all cases, the heater should generate enough heat from your UTV, side by side, or tractor engine that you may need to turn the heater off periodically otherwise the air in the cabin may be too hot.***

***It is important to check the coolant level regularly at least 4-5 times during the first several days of operation and fill as necessary until the coolant level has stabilized. The heater will draw and retain coolant, sometimes at the expense of coolant to the engine. This can cause engine overheating if not managed properly.***

CAB PREVIEW

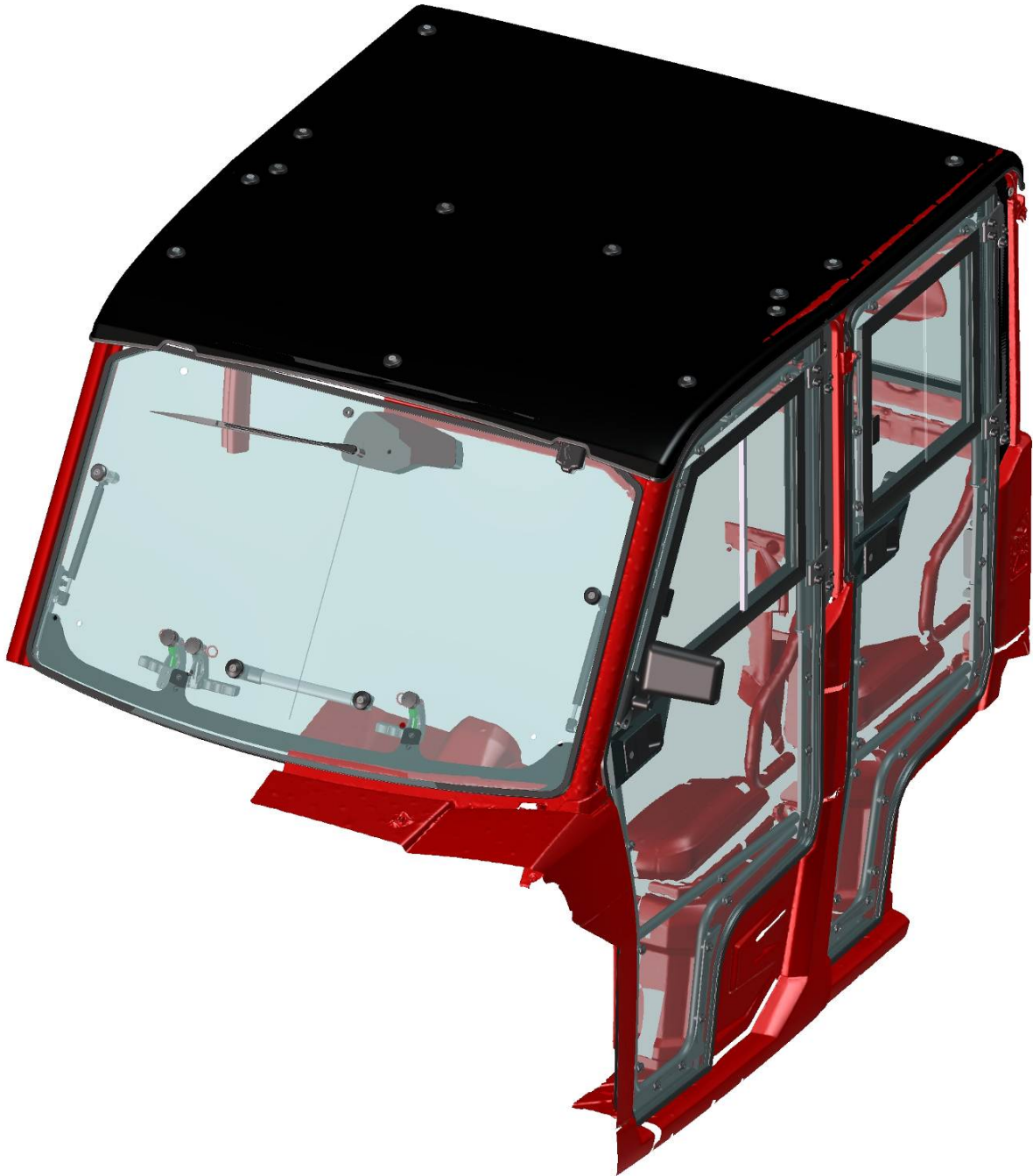

35

FOR ALL TECHNICAL QUESTIONS, PLEASE CALL  
DFK AMERICA INC.  
(630) 324-8585

**LEFT DOOR + RIGHT DOOR**

Remove the original screws (in blue circles) from the roller cage, and save these carefully

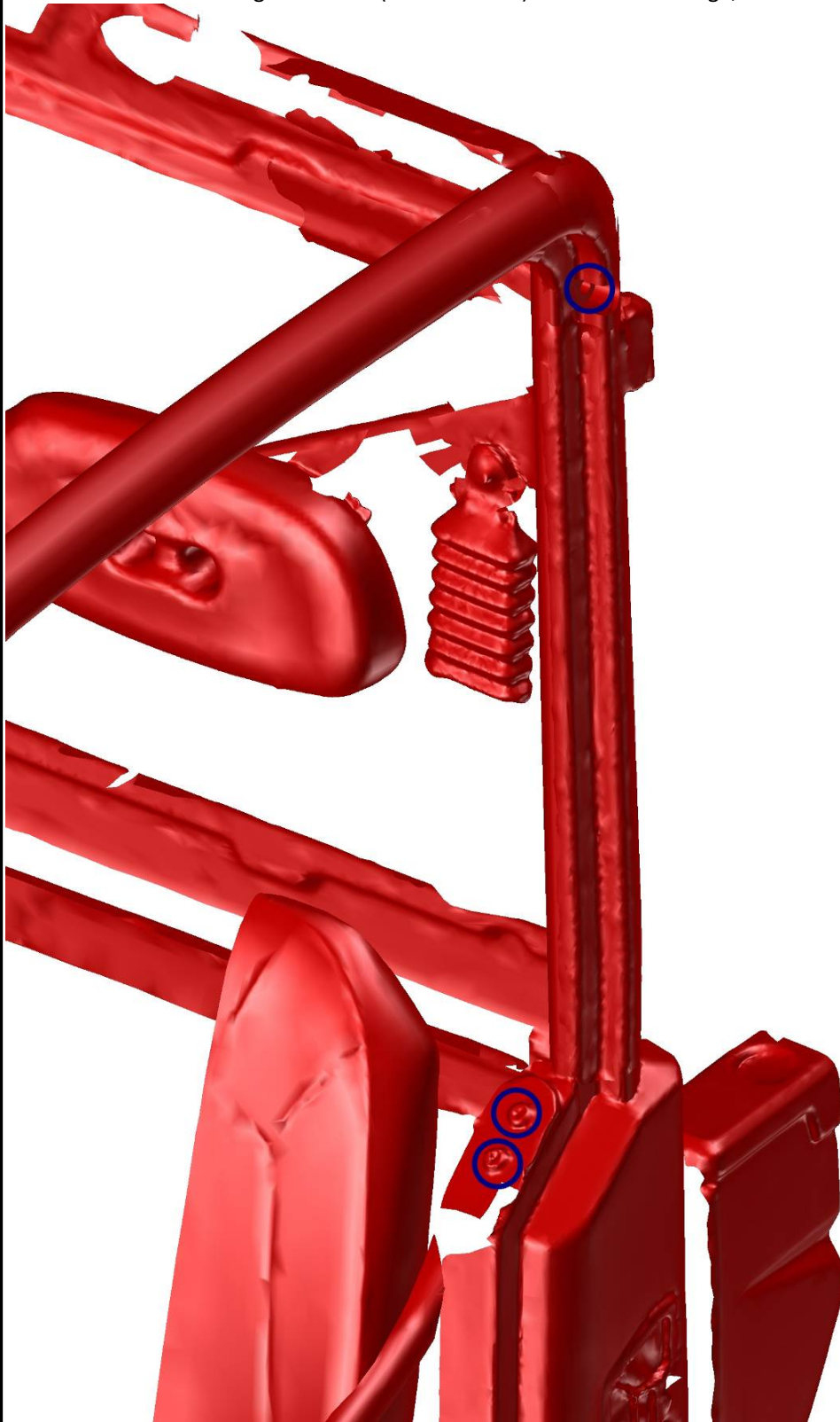

FOR ALL TECHNICAL QUESTIONS, PLEASE CALL  
DFK AMERICA INC.  
(630) 324-8585

Place the left door base onto the roller cage and adjust that onto the best position.

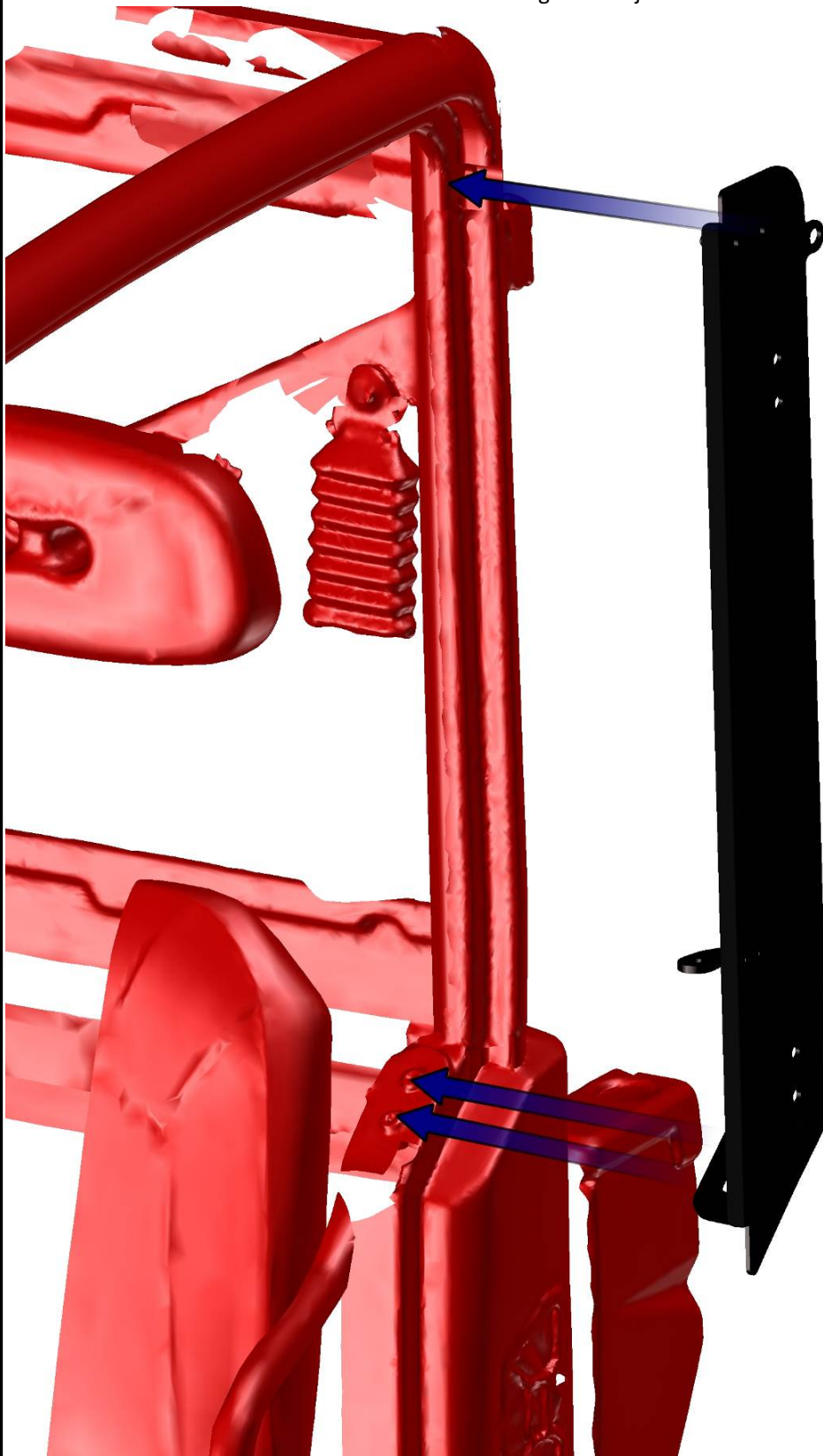

Fix the door base with the roller cage by original screws from page No.: 36.



38

Fix the door base with the roller cage by original screw from page No.: 36.

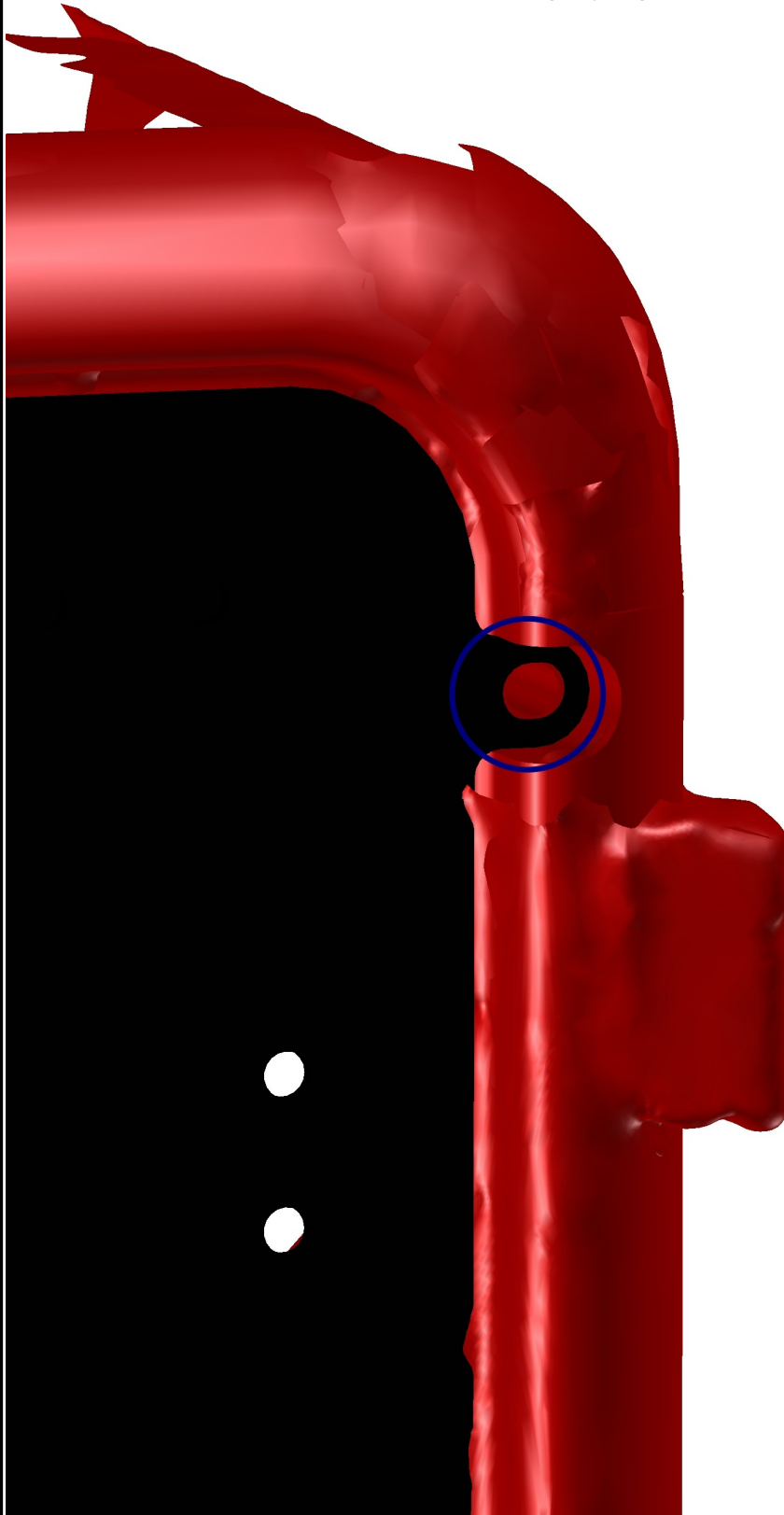

Place the door base ledge onto the door base and onto the roller cage.

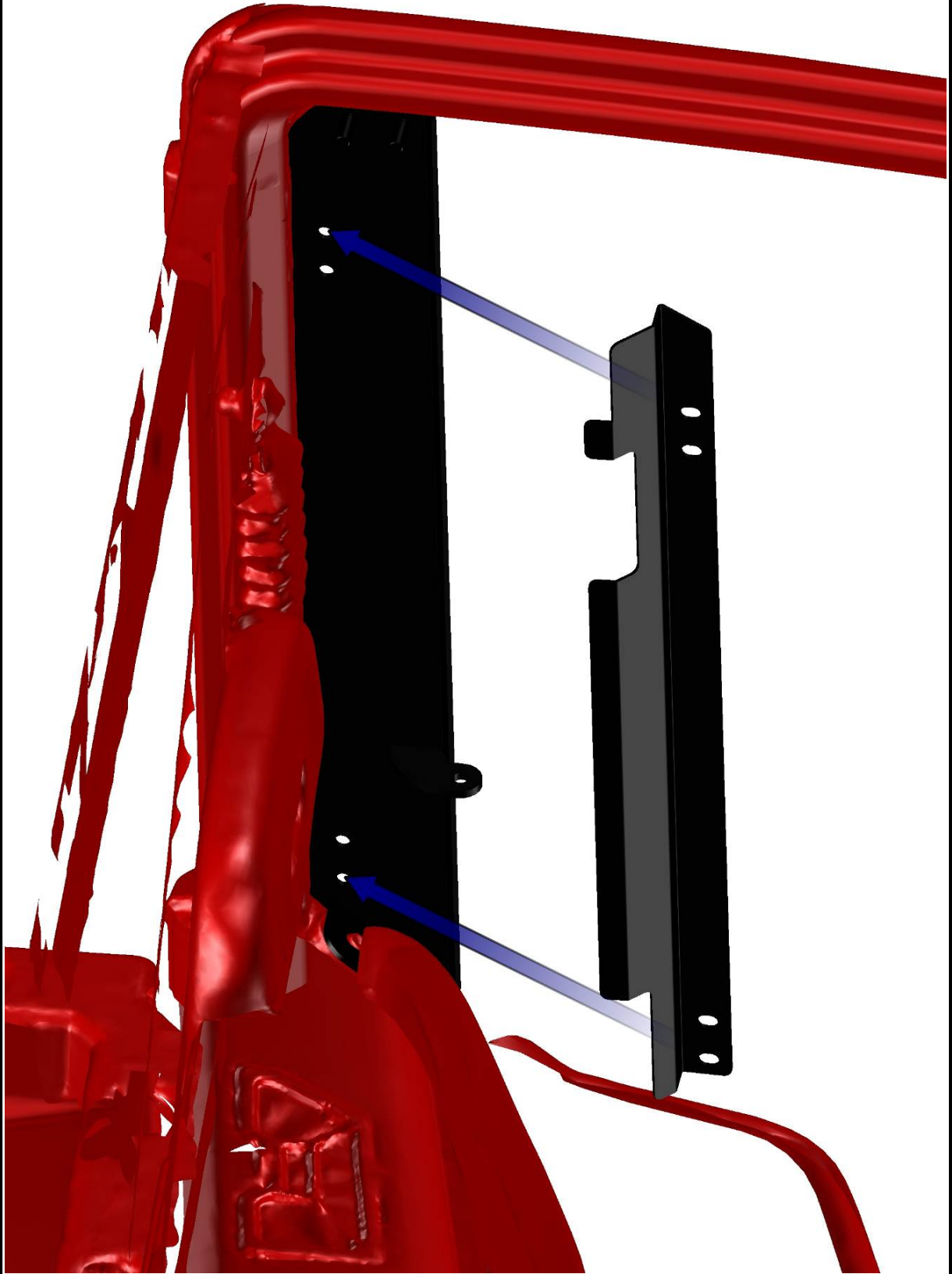



Place the correct hinges onto the door base.

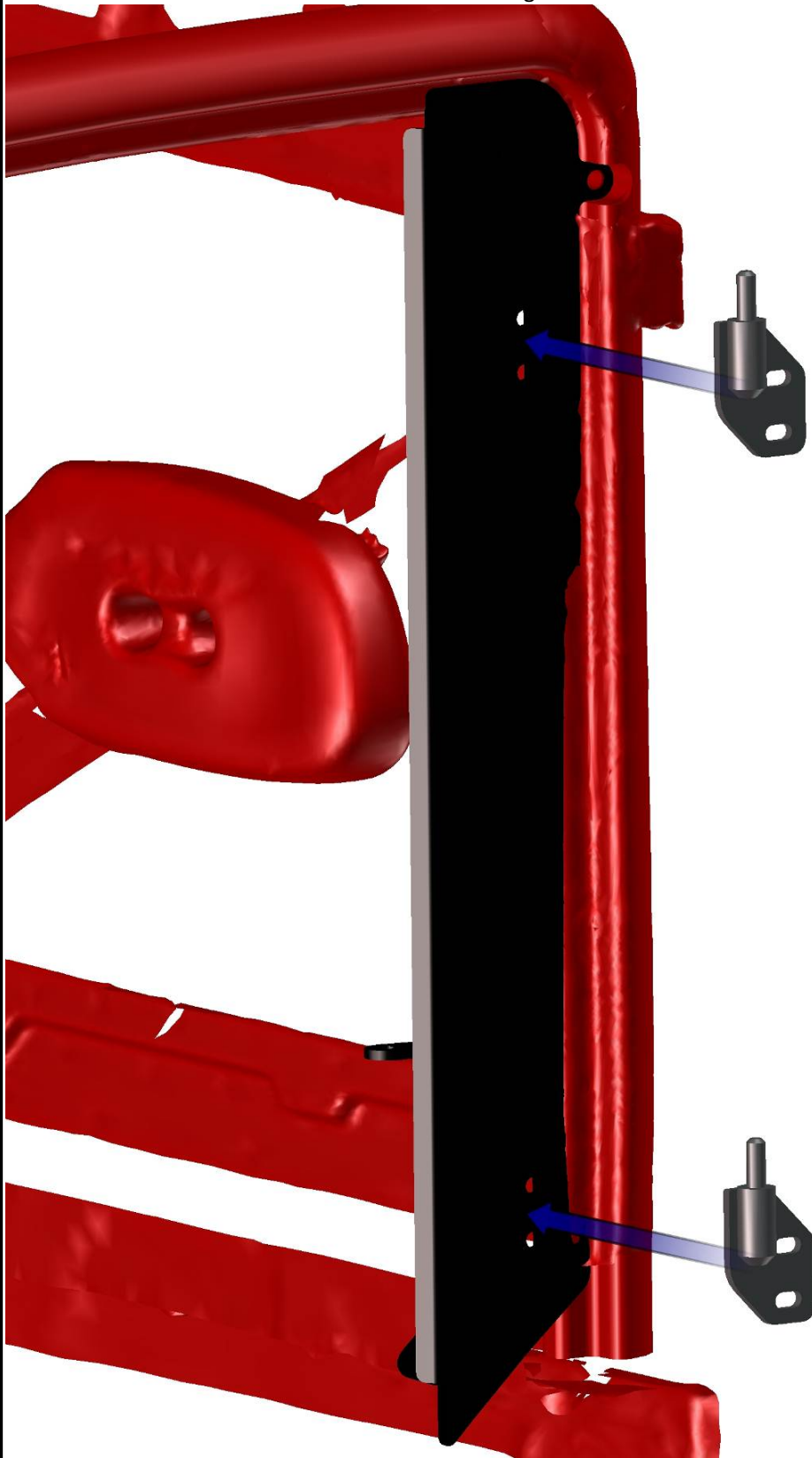

Fix the hinges with the door base and with the door base ledge by screws, washers, nuts and nut covers.

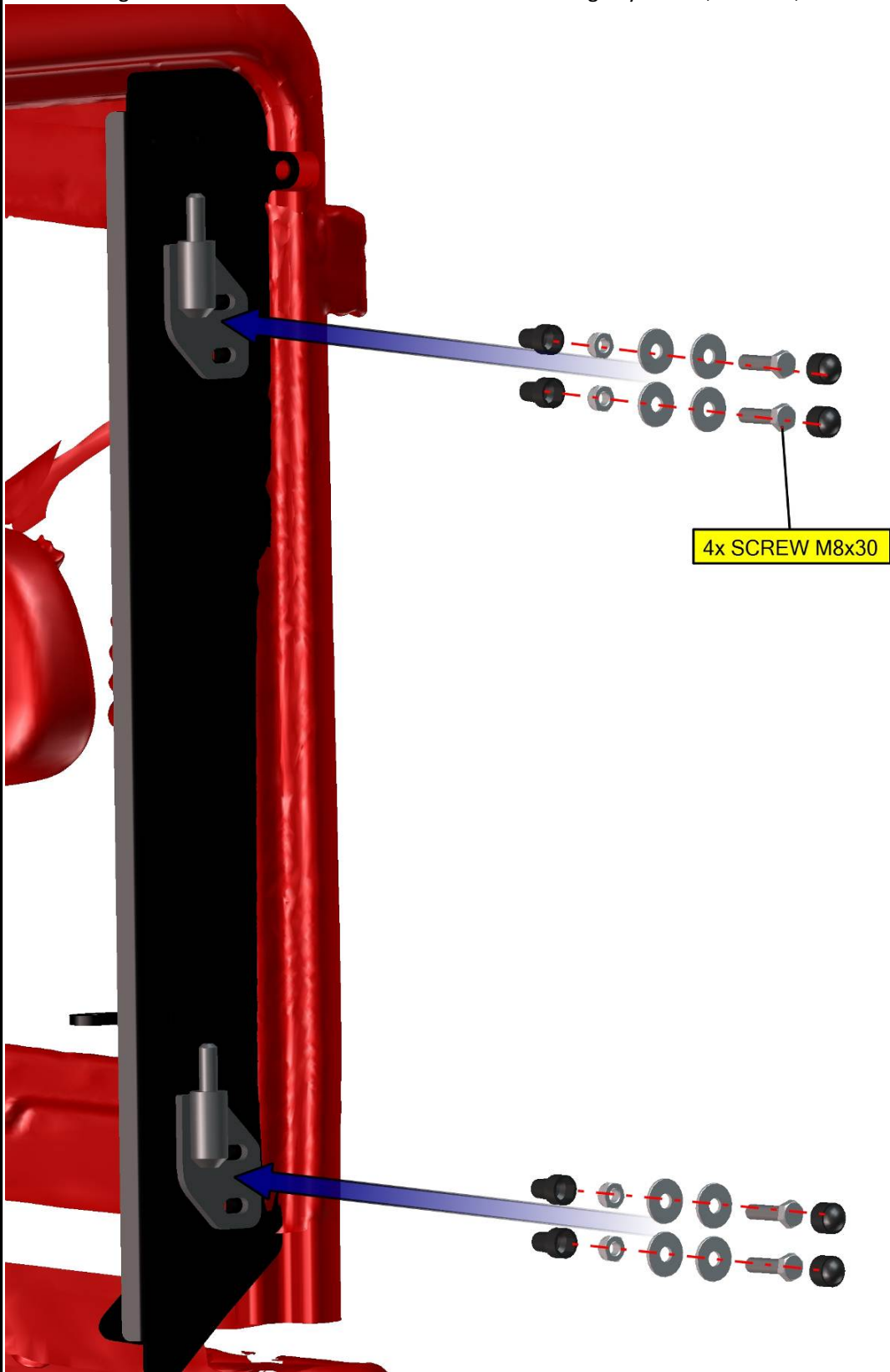

FOR ALL TECHNICAL QUESTIONS, PLEASE CALL  
DFK AMERICA INC.  
(630) 324-8585

Place the door base holder onto the door base and onto the roller cage.

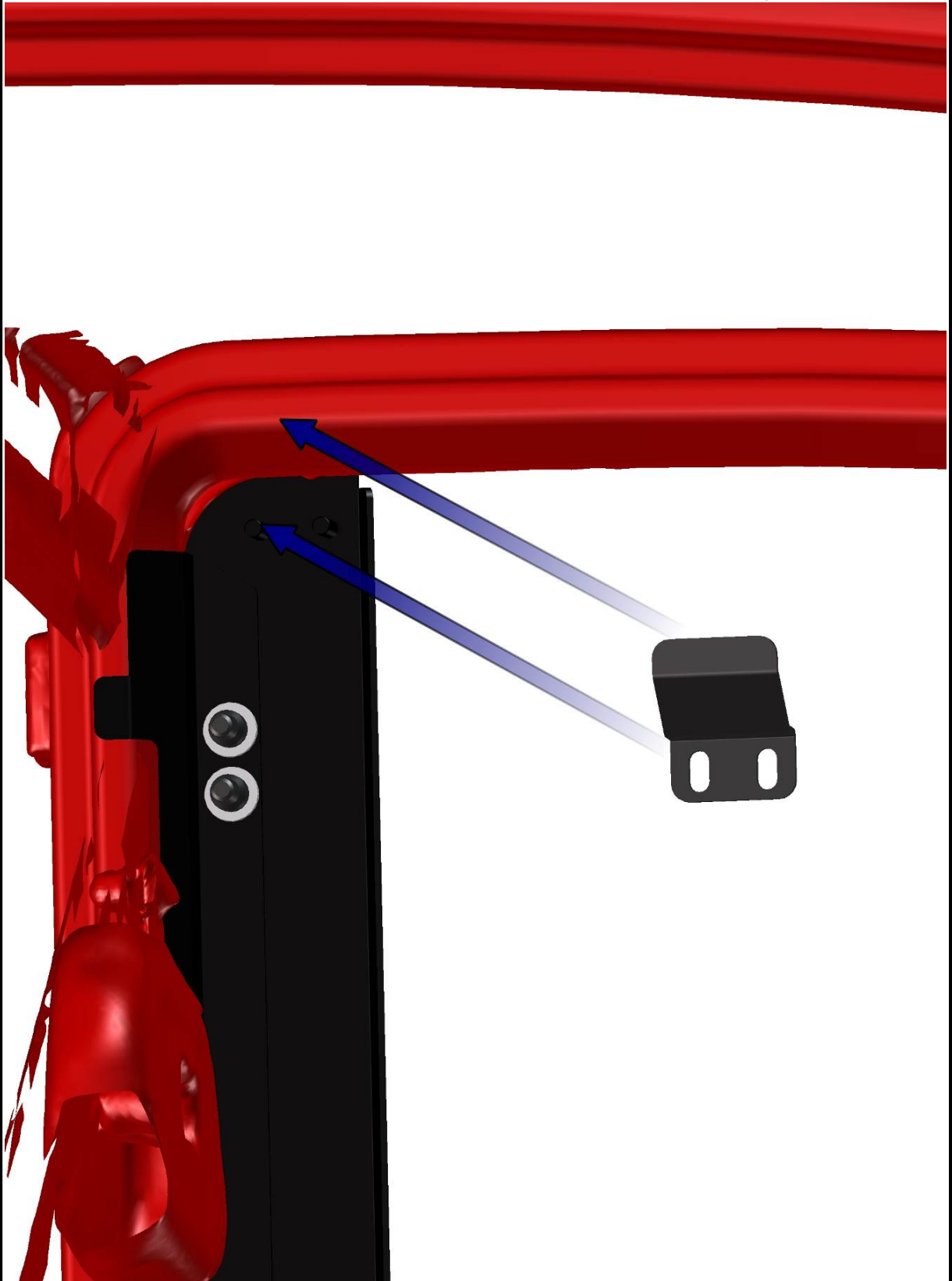

Fix the door base holder with the door base to the roller cage by nuts, washers and nut covers.

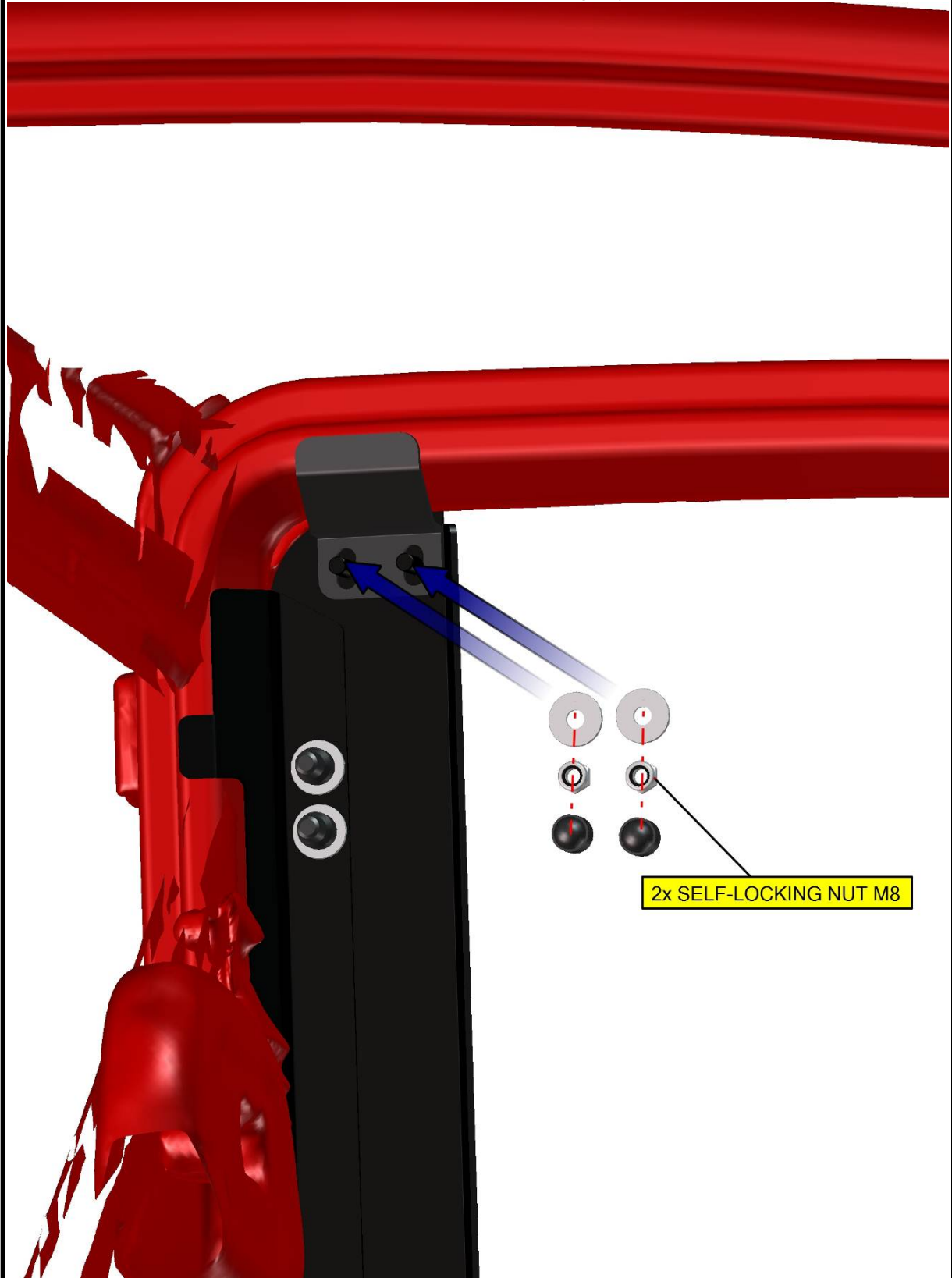

Repeat previous steps with the second left door base assembly.

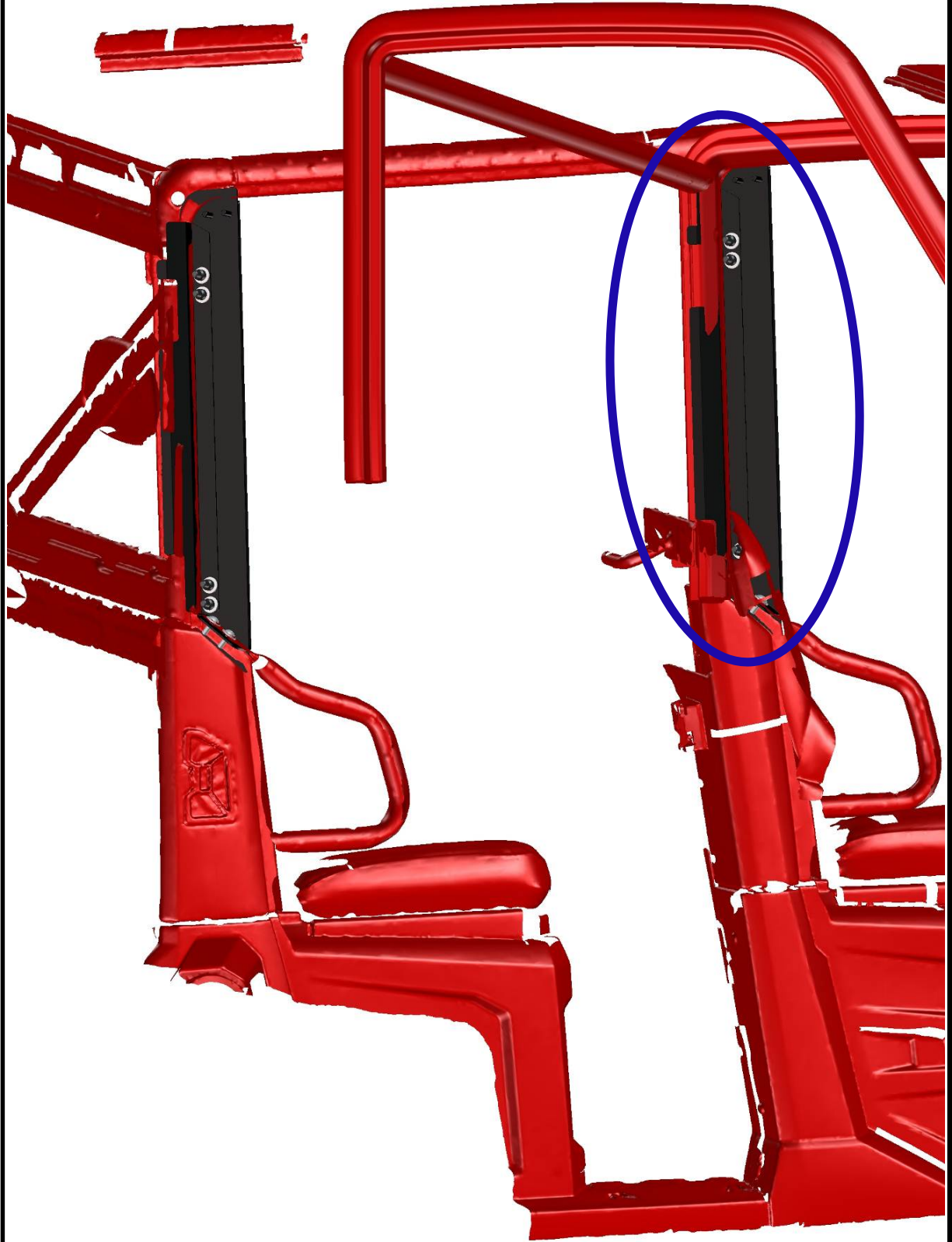

Lubricate the hinge's pins and insert washer 10 onto the pins. Place the door onto the hinges pins.

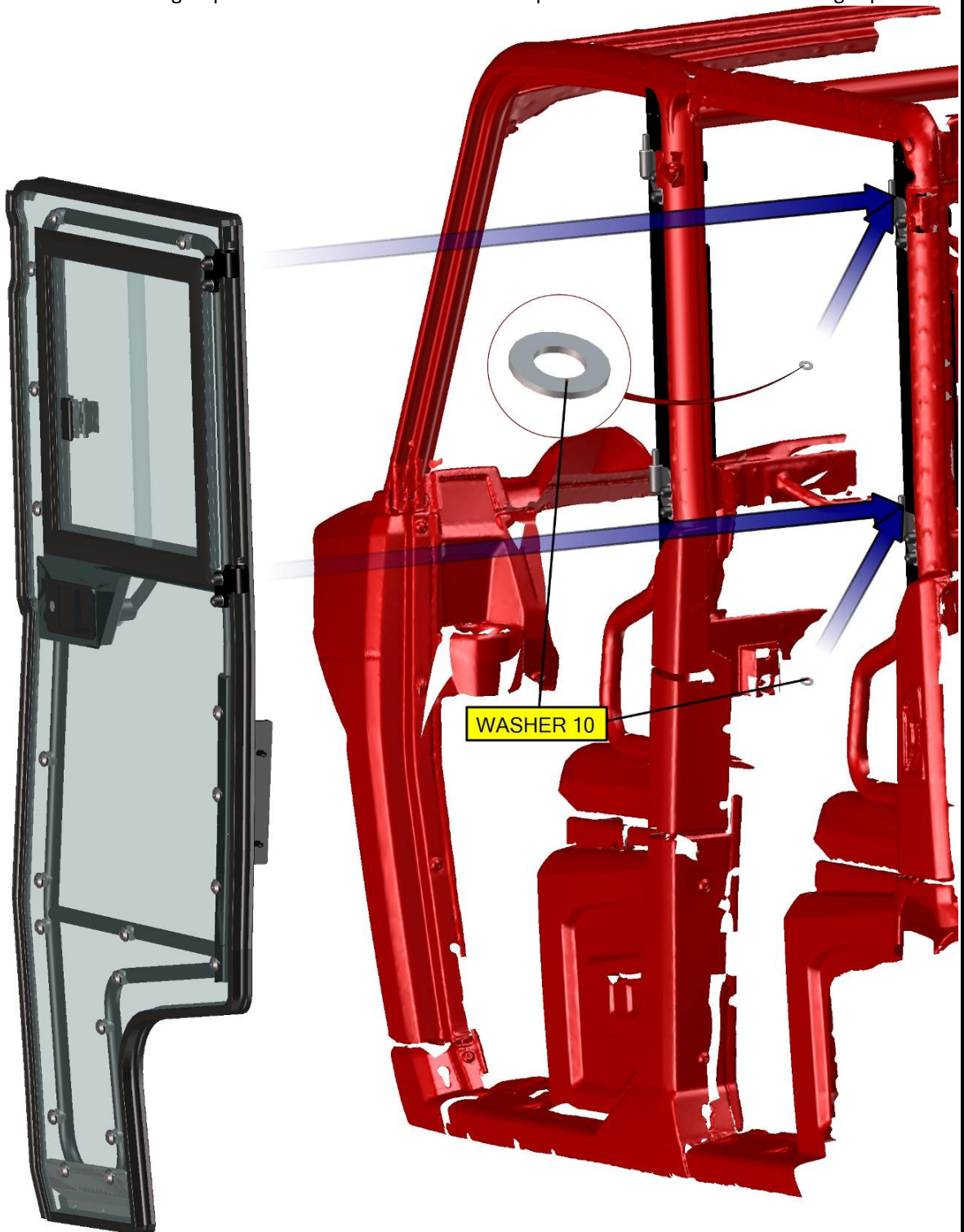

46

Adjust the door to best position by the hinges and tighten the hinge's screws and nuts hard.

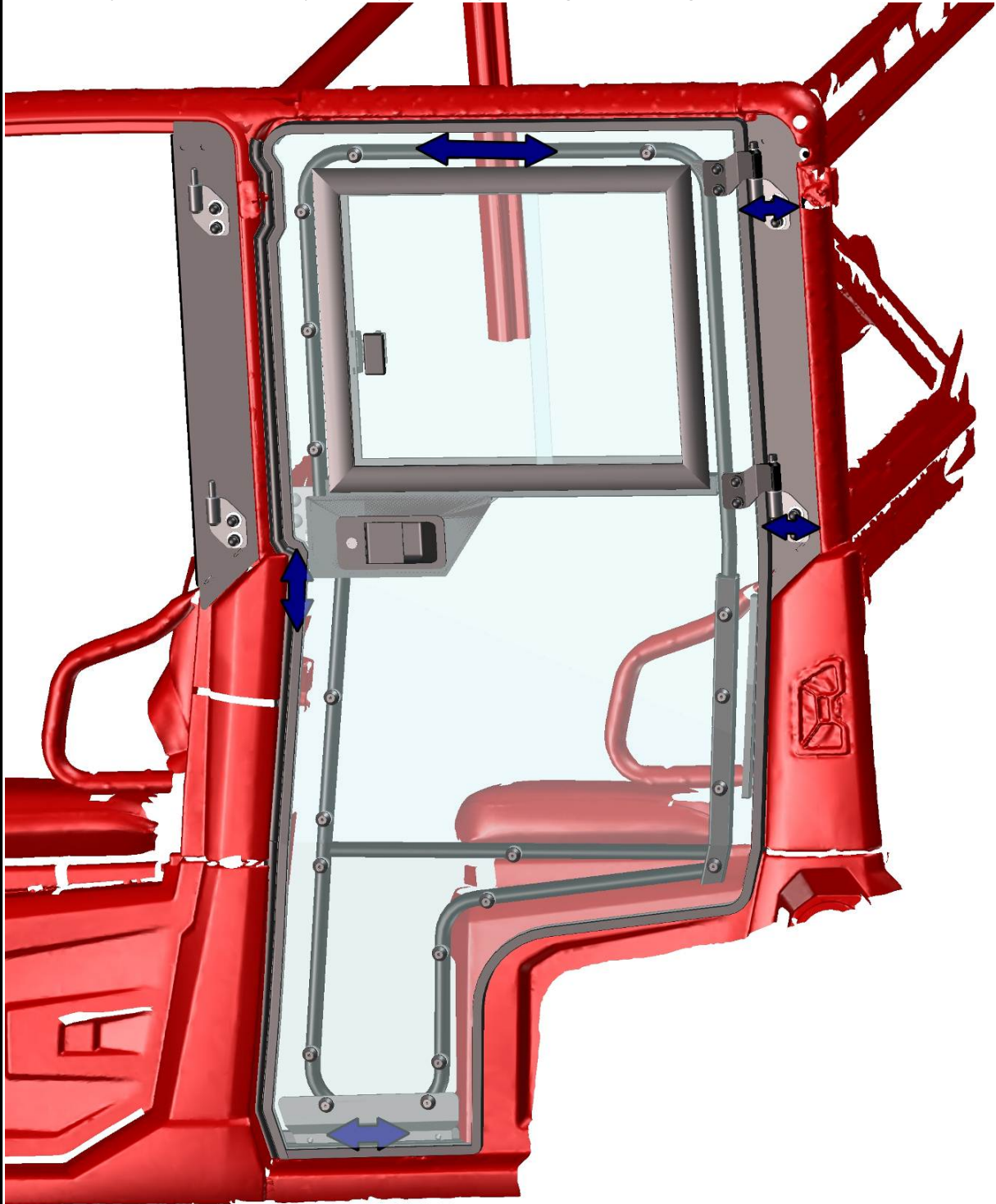

47

FOR ALL TECHNICAL QUESTIONS, PLEASE CALL  
DFK AMERICA INC.  
(630) 324-8585

Install door stop assembly into the REAR door stop holder.

**Use the LEFT door stop holder (on picture) on LEFT side of the roller cage.  
YOU CAN'T MAKE MISTAKE BETWEEN LEFT AND RIGHT PARTS, IF YOU MAKE MISTAKE,  
YOU ARE GOING TO HAVE BIG PROBLEM WITH DOOR STOP ADJUSTING!**

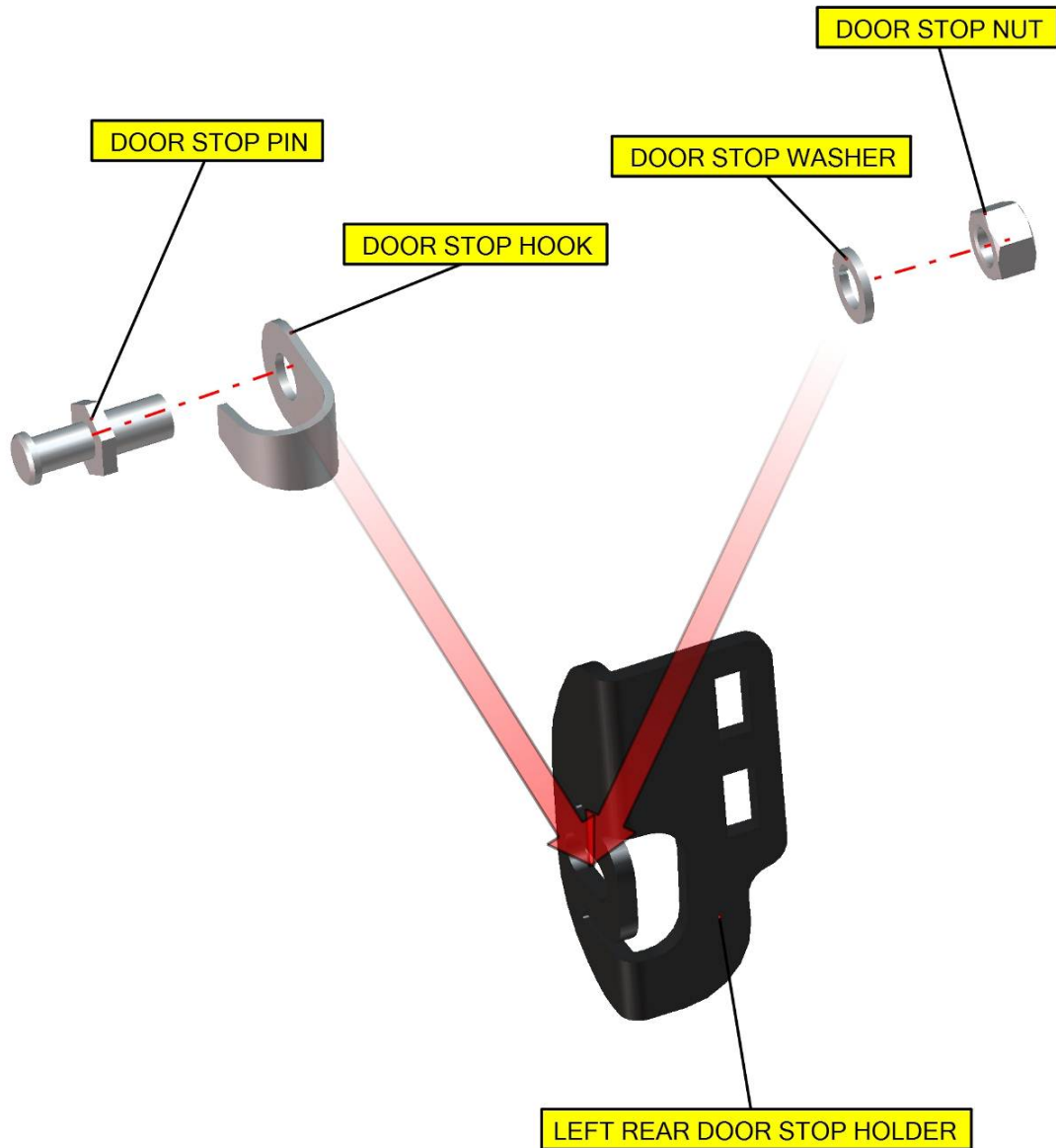



Place the door stop holder onto the roller cage reinforcement.

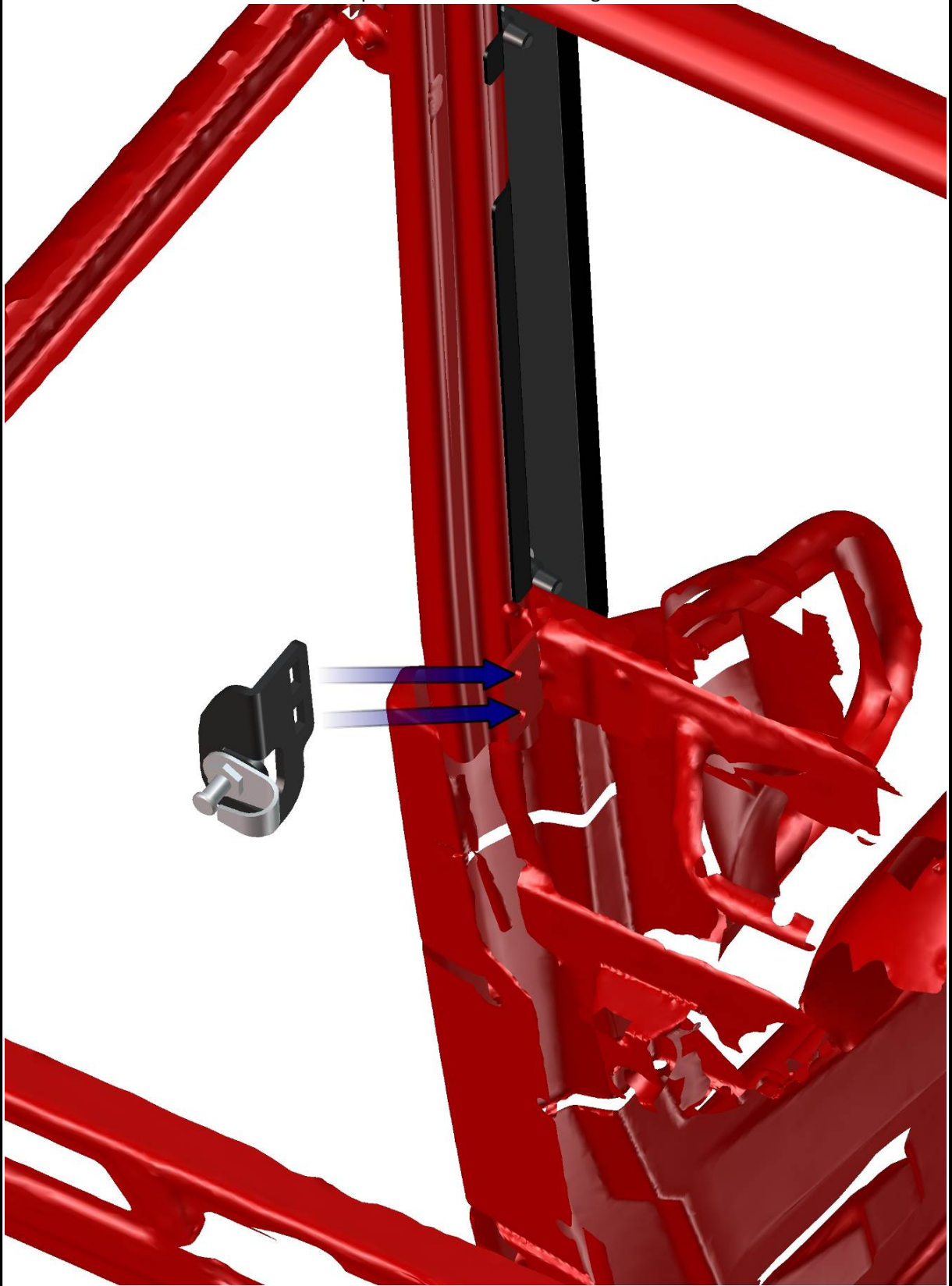

Fix the holder with the reinforcement by screws, washers, nuts and covers.

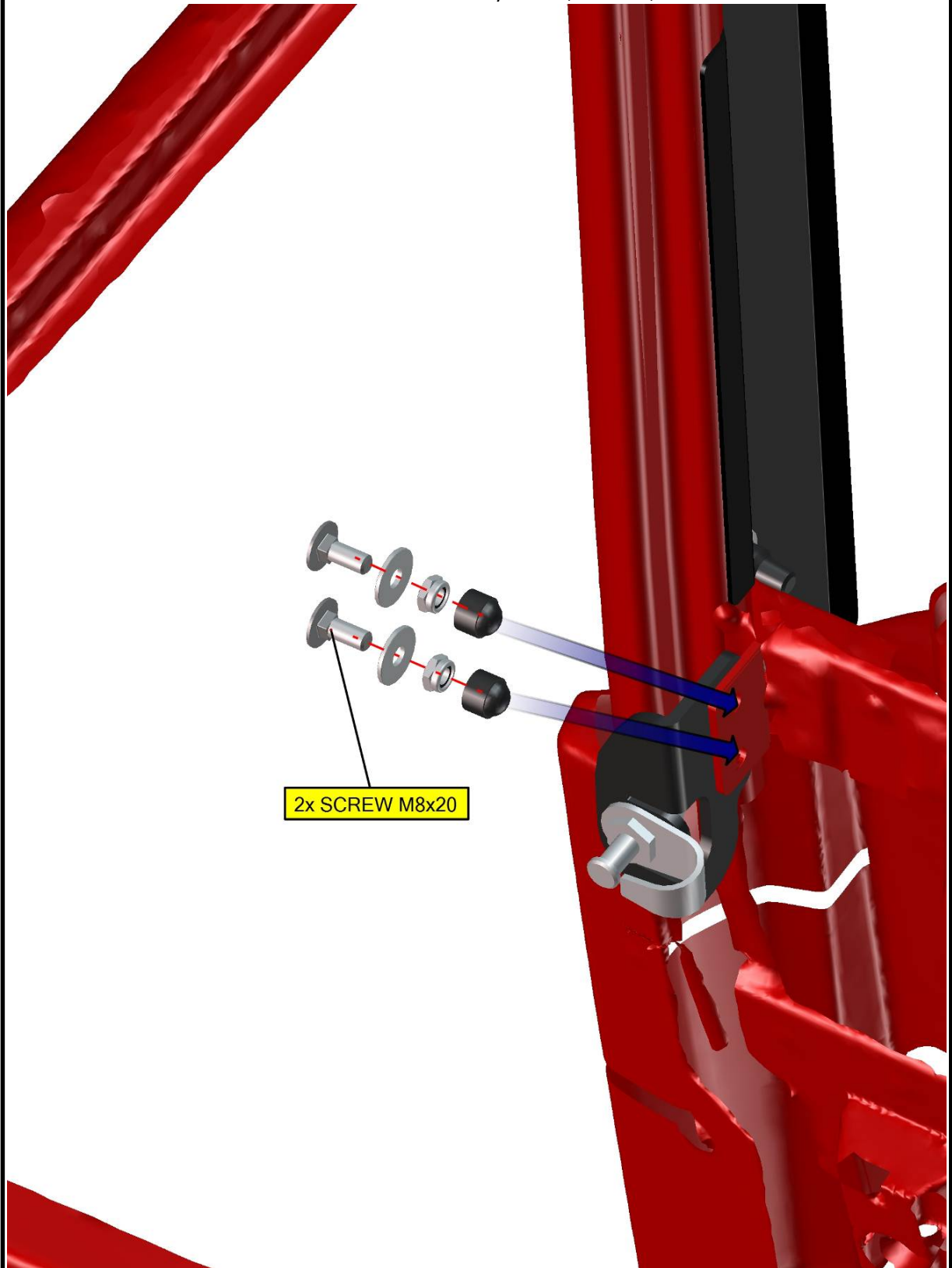

Close the door and adjust the door stop to best position in accordance with the door lock inner mechanism.

**If you adjust the door stop correctly and close door slowly, you can hear two clear metallic click.**

If you have problems with the door stop adjusting, you can repeat steps from page No.: 47.

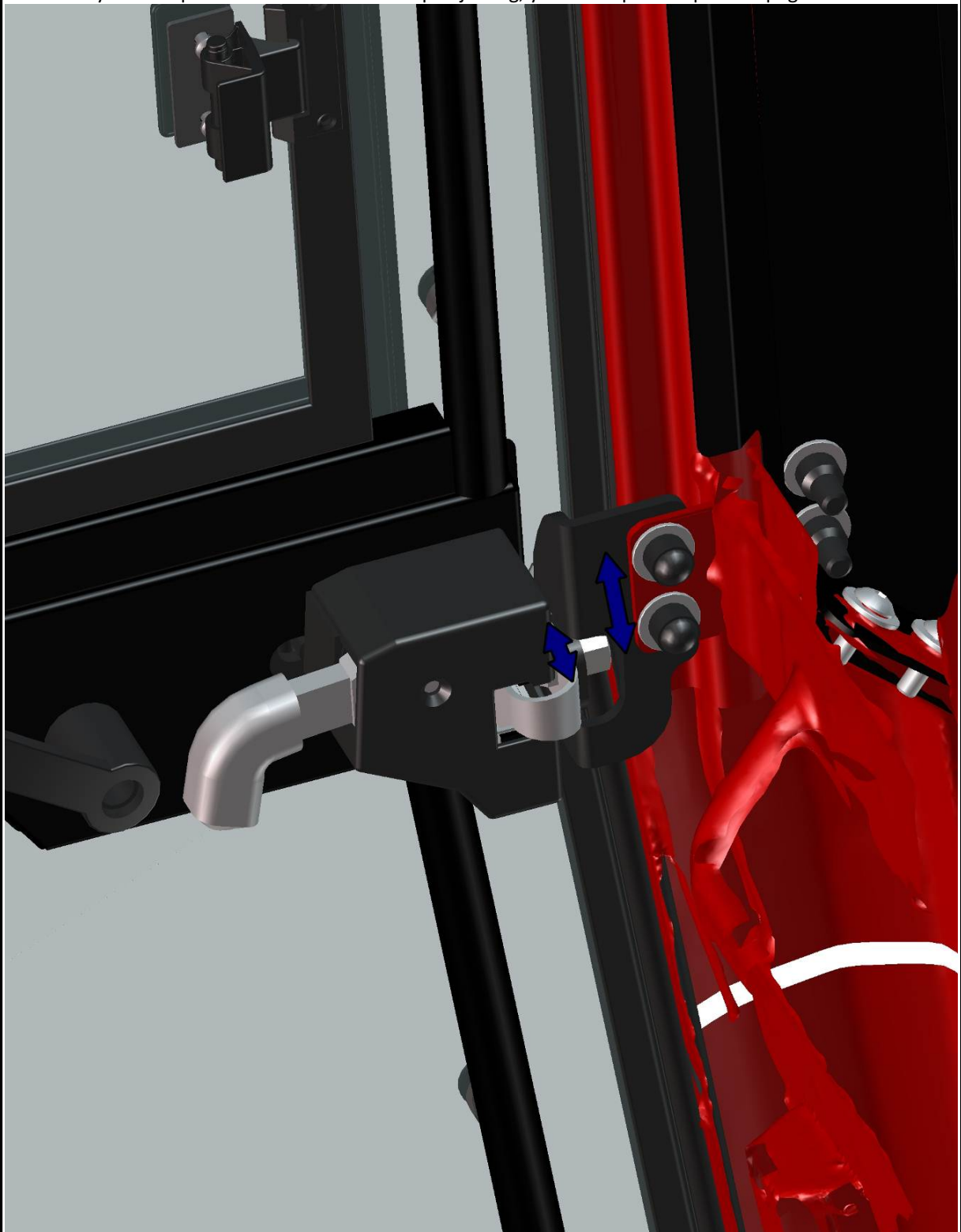

51

Lubricate the hinge's pins and insert washer 10 onto the pins. Place the door onto the hinges pins.

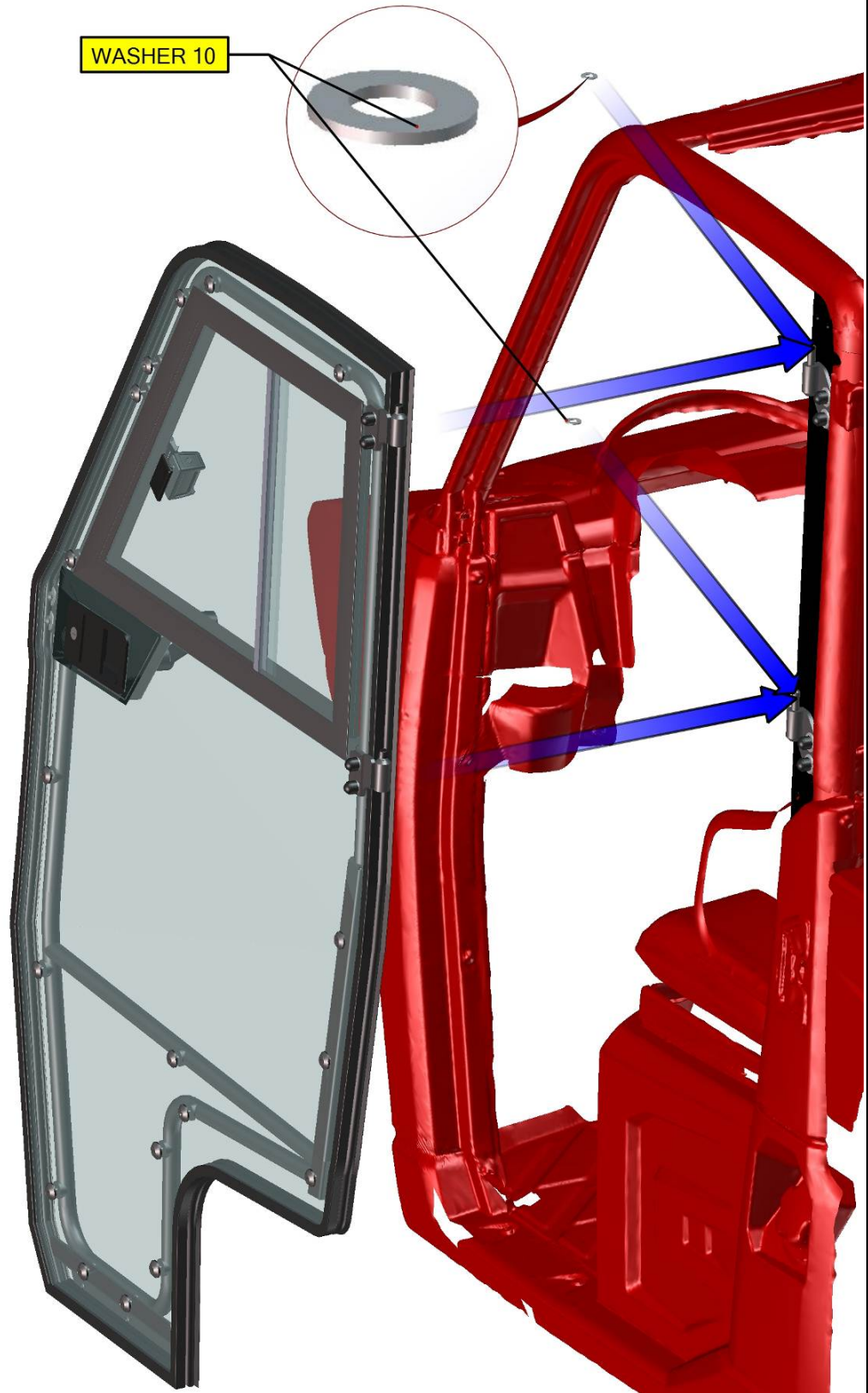

52

Adjust the door to best position by the hinges and tighten the hinge's screws and nuts hard.



53

FOR ALL TECHNICAL QUESTIONS, PLEASE CALL  
DFK AMERICA INC.  
(630) 324-8585

Install door stop assembly into the FRONT door stop holder.

*Use the LEFT door stop holder (on picture) on LEFT side of the roller cage.  
YOU CAN'T MAKE MISTAKE BETWEEN LEFT AND RIGHT PARTS, IF YOU MAKE MISTAKE,  
YOU ARE GOING TO HAVE BIG PROBLEM WITH DOOR STOP ADJUSTING!*

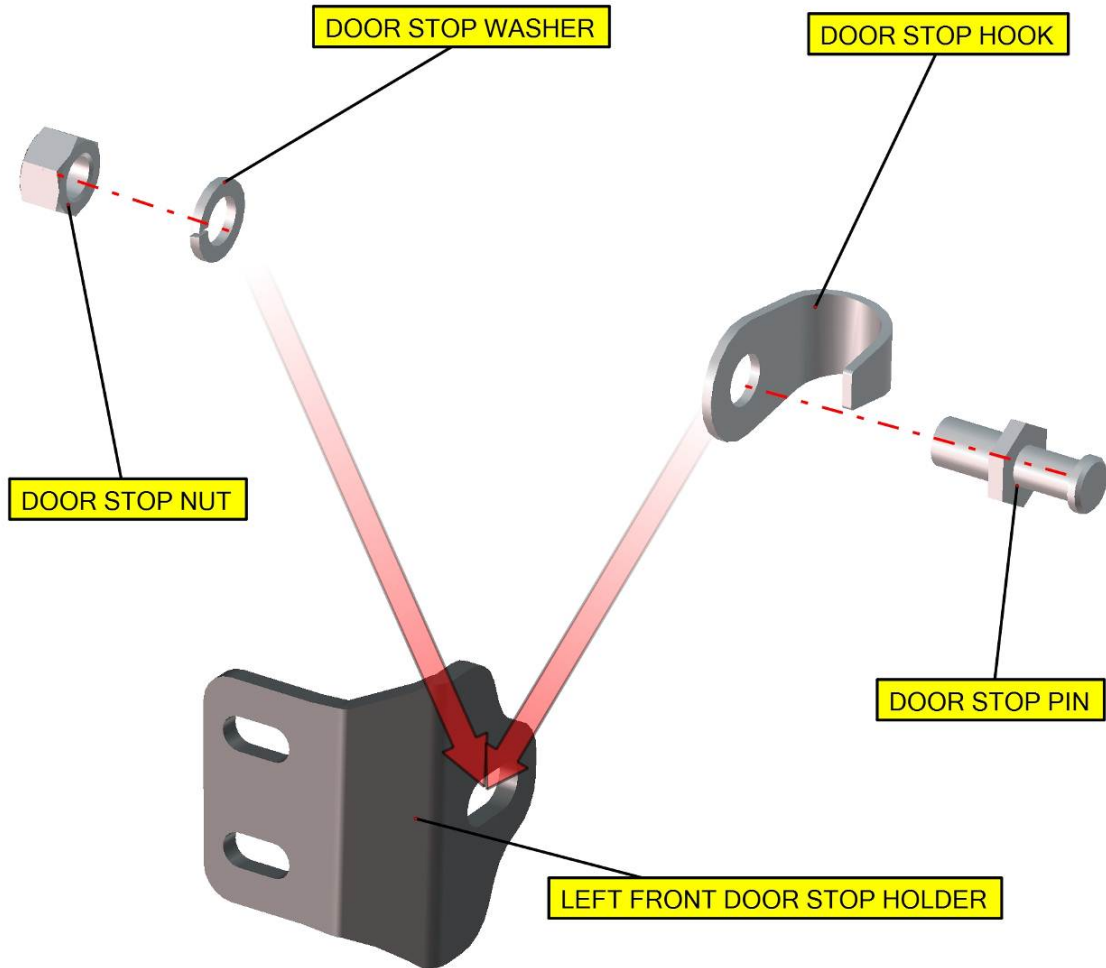

Uninstall original screws (in green circles) from roller cage and place the door stop holder onto the roller cage.

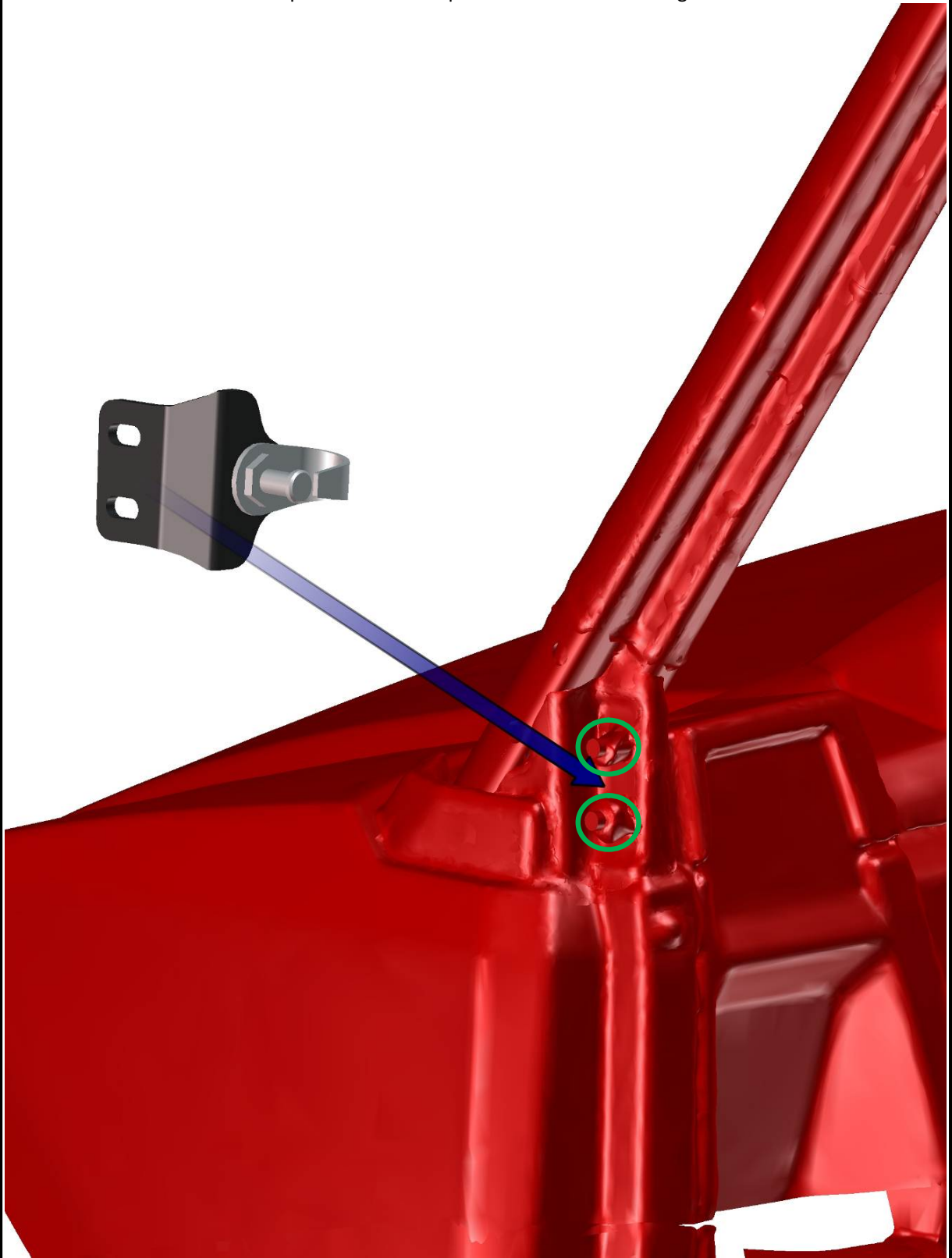

55

Fix the door stop holder with the roller cage by screws and washers.

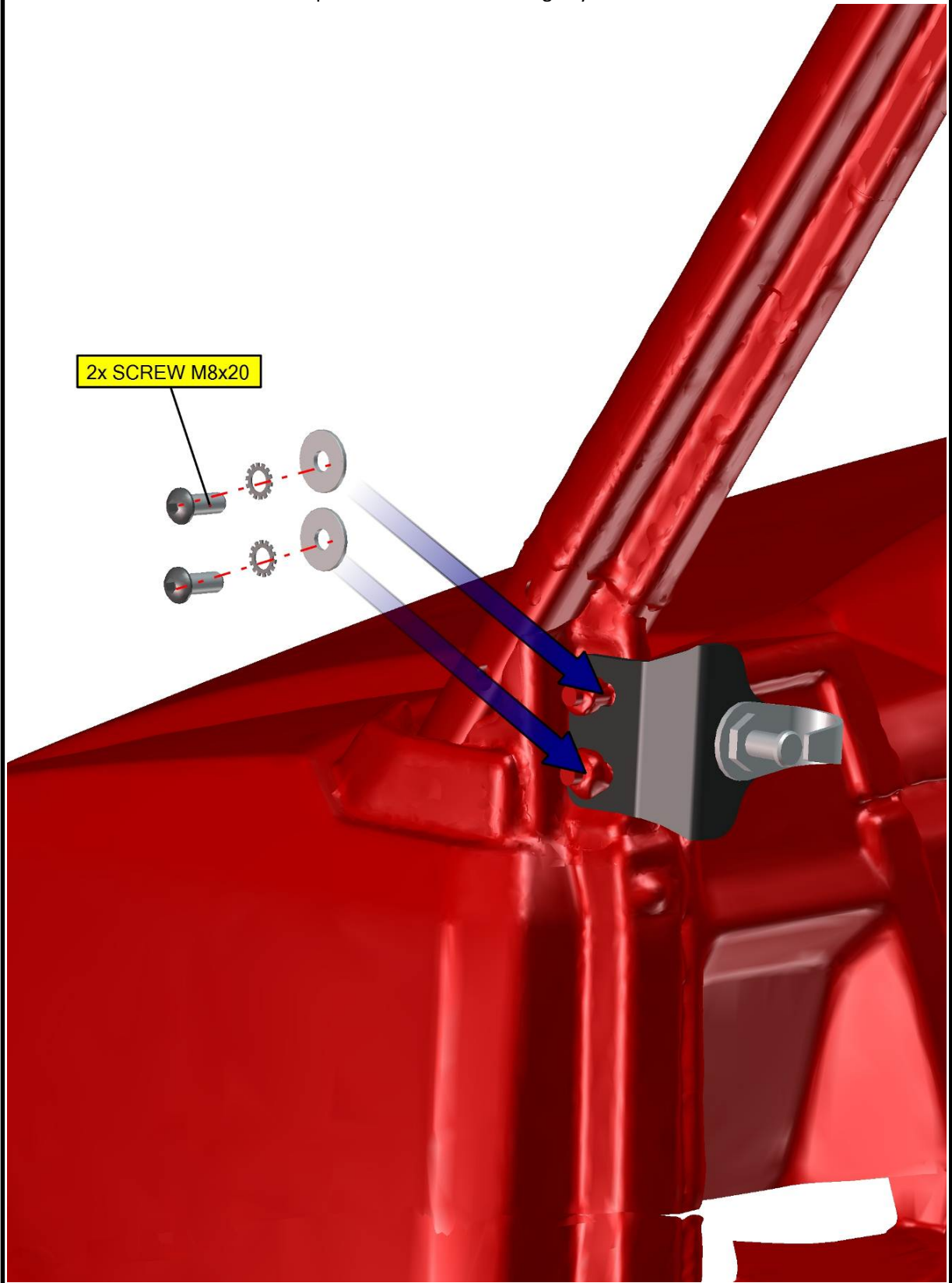



Close the door and adjust the door stop to best position in accordance with the door lock inner mechanism.  
If you adjust the door stop correctly and close door slowly, you can hear two clear metallic click.  
If you have problems with the door stop adjusting, you can repeat steps from page No.: 53.

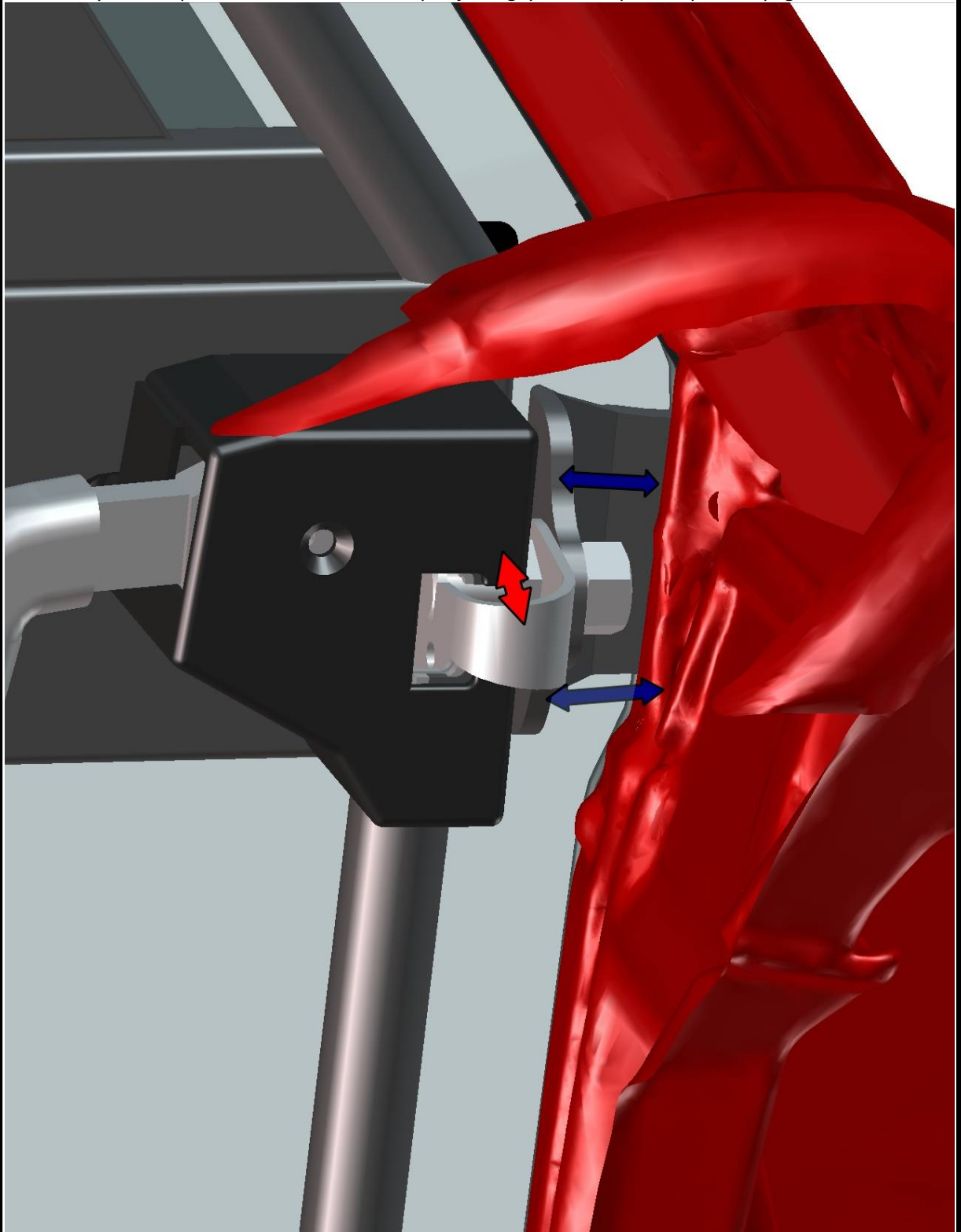

57

Loosen the door's nut (in green circles) and adjust the door bottom epdm ledge to best position.

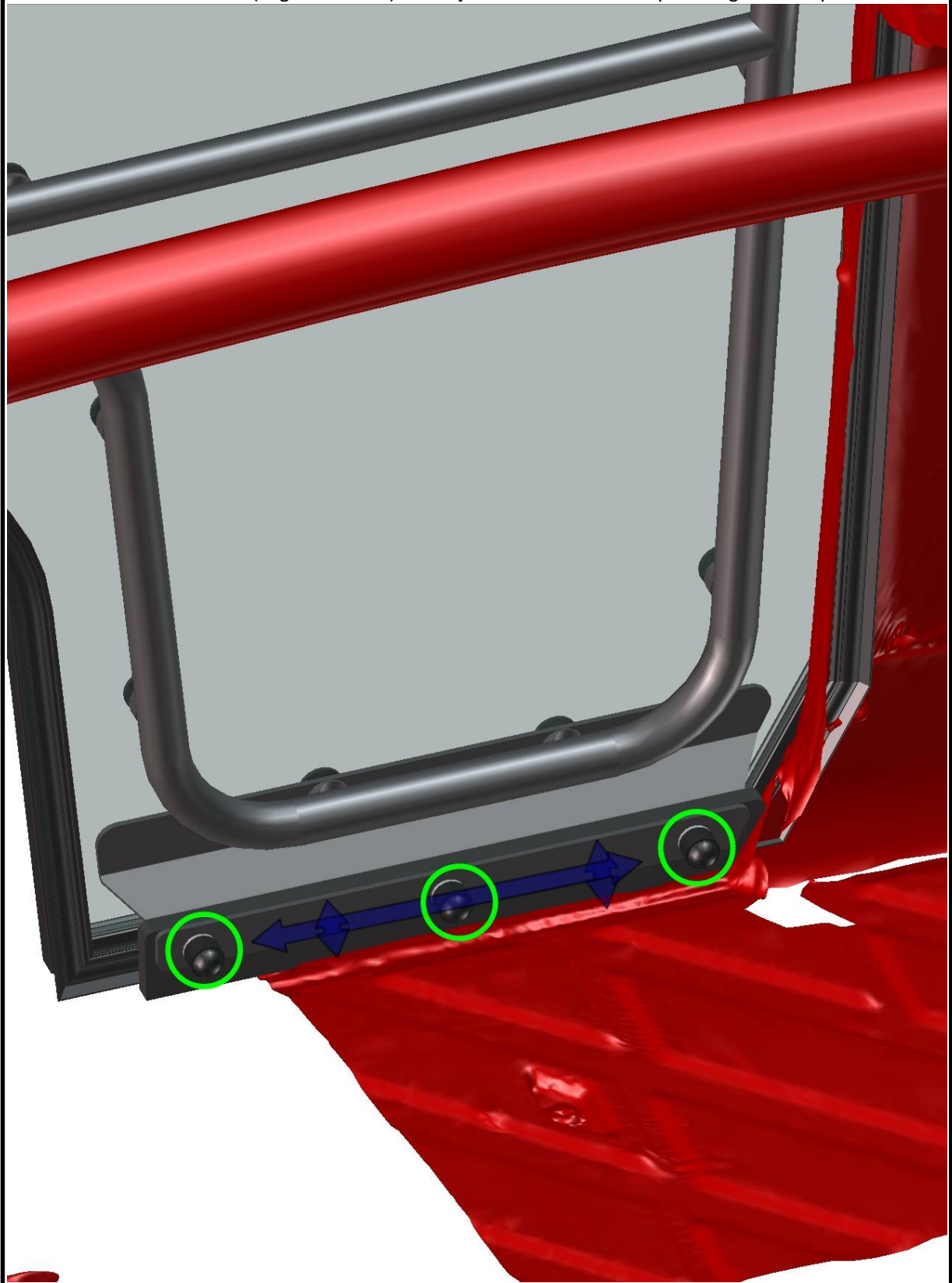

58

FOR ALL TECHNICAL QUESTIONS, PLEASE CALL  
DFK AMERICA INC.  
(630) 324-8585

Install the gas spring into the gas spring holder (blue part in picture for better orientation).  
Fix the gas spring with the holder by nut, washer and nut cover.

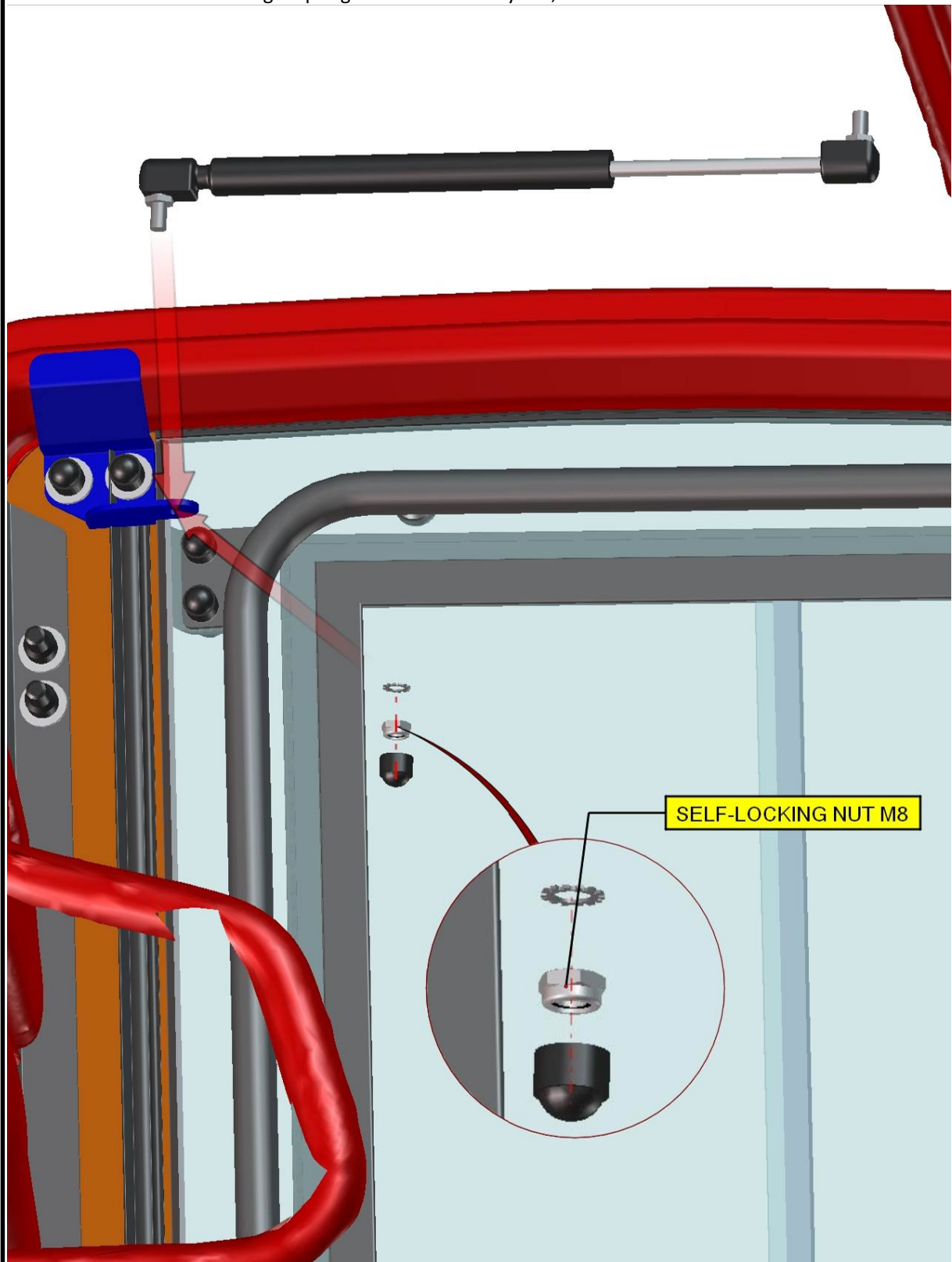

59

FOR ALL TECHNICAL QUESTIONS, PLEASE CALL  
DFK AMERICA INC.  
(630) 324-8585

Install the gas spring holder onto the gas spring pin.

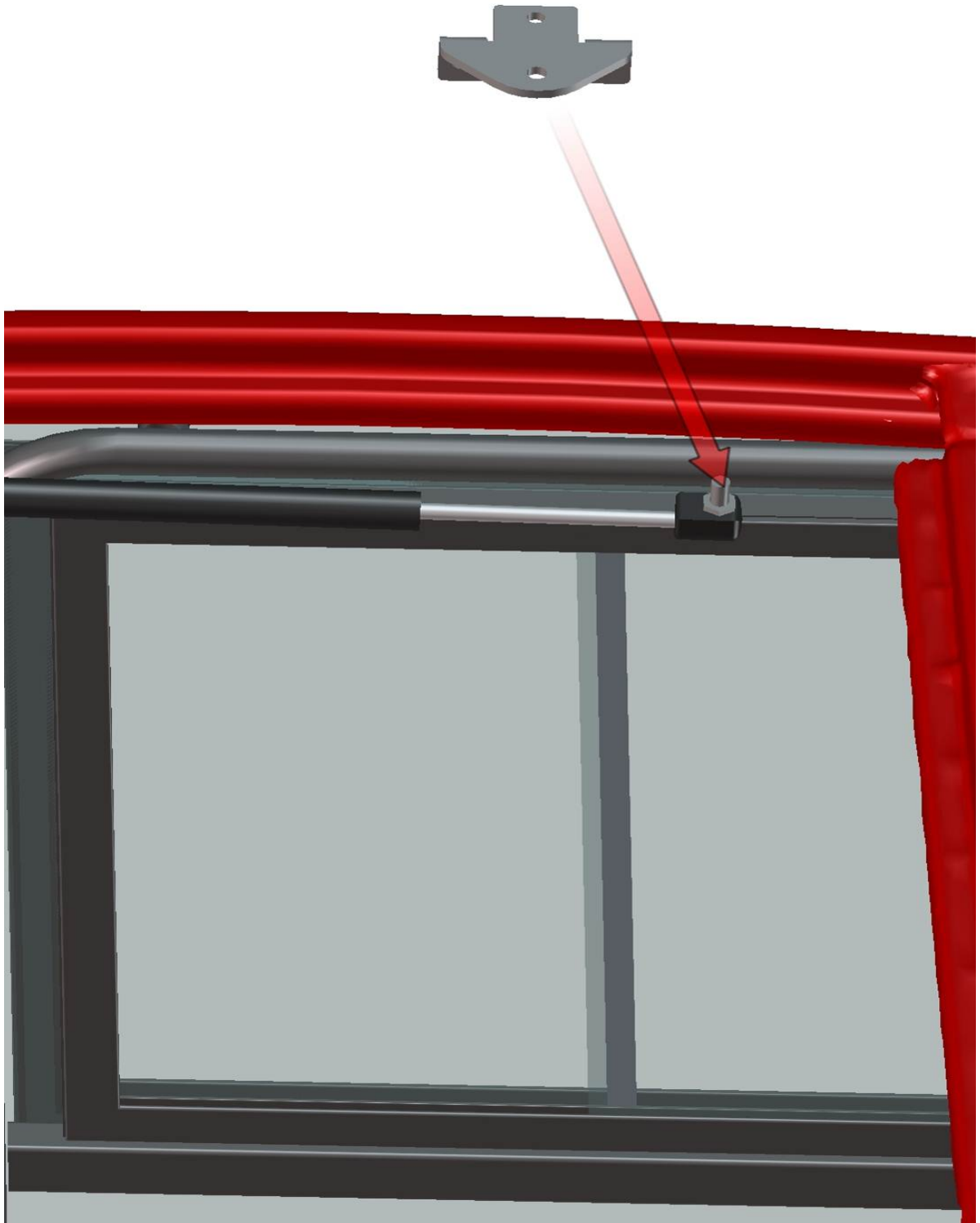

60

Adjust the gas spring holder to best position.

**IT IS IMPORTANT TO INSTALL GAS SPRING IN SAME ORIENTATION LIKE IN PICTURE**

(If you adjust holder more to rear side, door is open to bigger angle.)



61

Fix the gas spring holder with the door frame by TEX screws, washers and TEX covers.  
(You can take out the gas spring for easier fixation, and after that, place gas spring back to holder.)

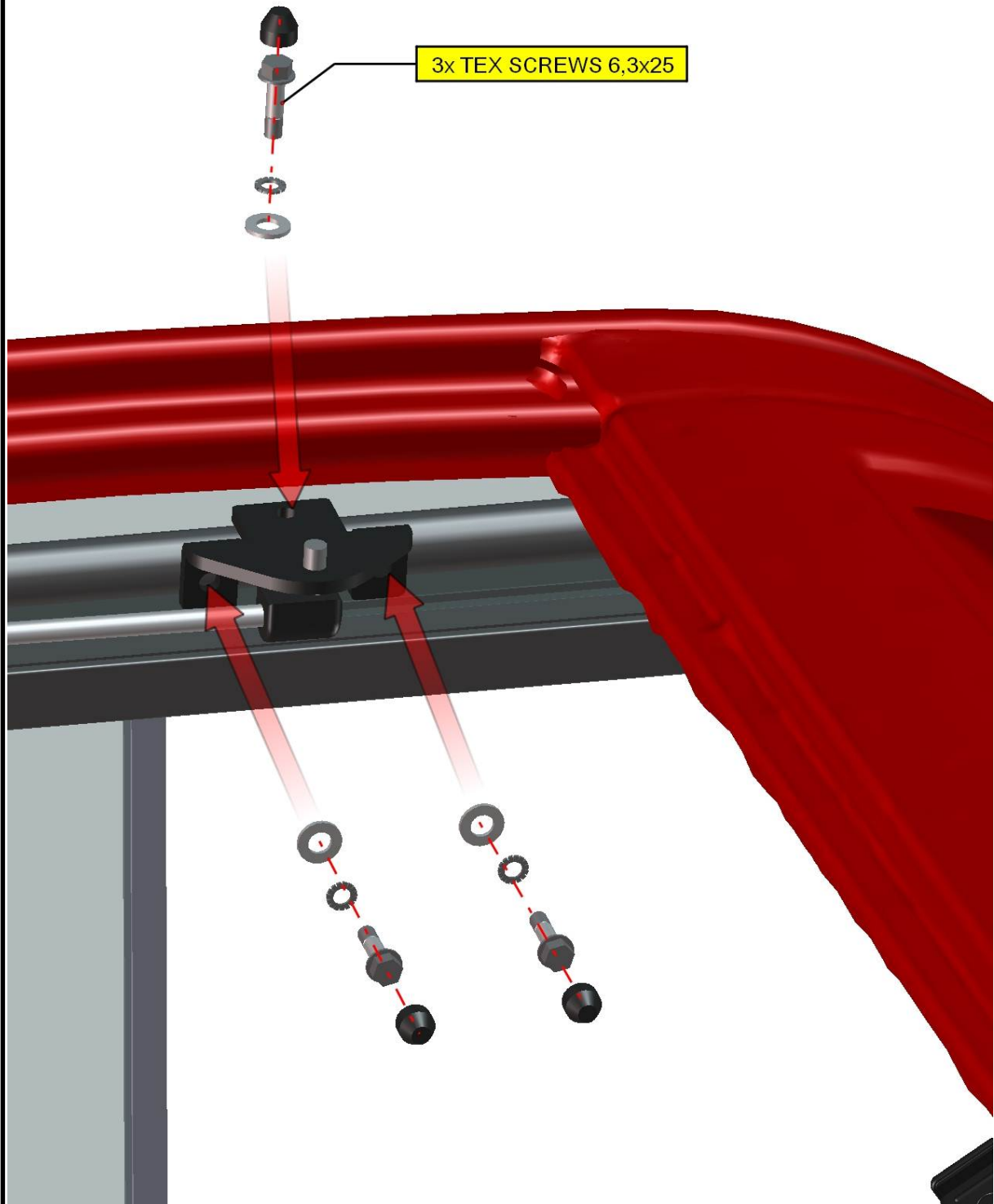

Fix the gas spring with the holder by nut, washer and nut cover.

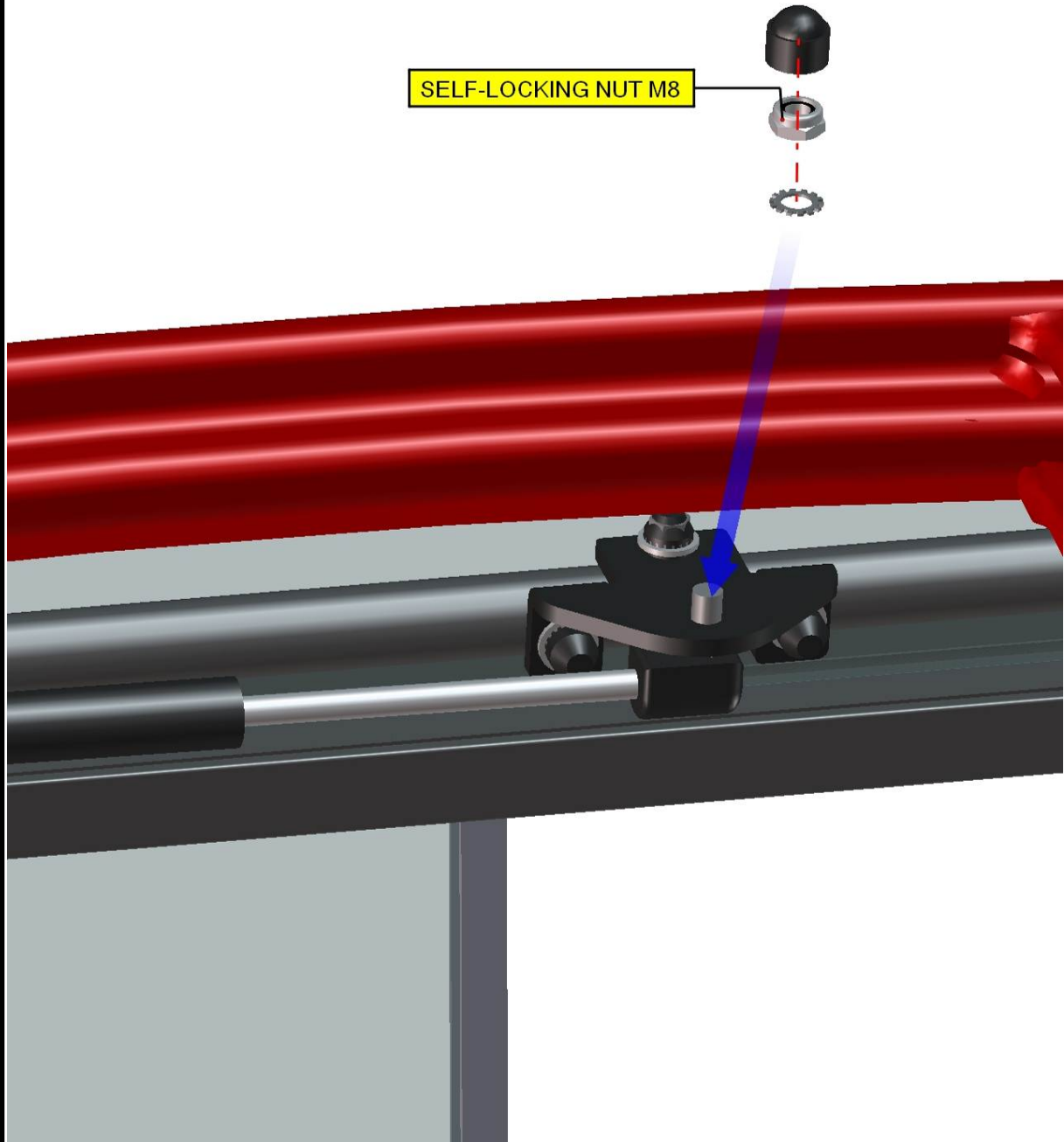
**63**

Repeat previous steps with the rear door and second left gas spring assembly.

FOR ALL TECHNICAL QUESTIONS, PLEASE CALL  
DFK AMERICA INC.  
(630) 324-8585

Place the front central EPDM assembly onto the door panel.

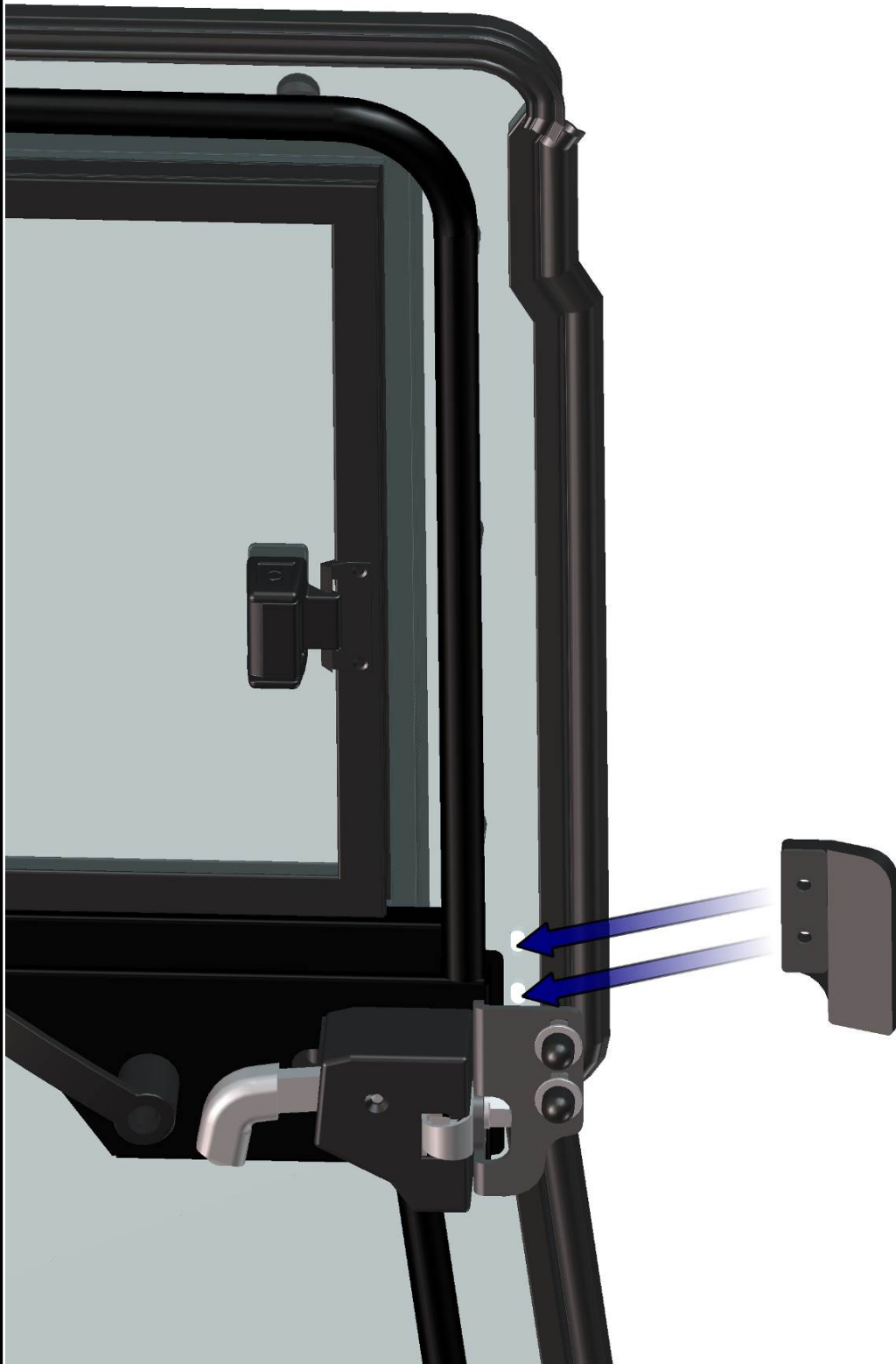

64

FOR ALL TECHNICAL QUESTIONS, PLEASE CALL  
DFK AMERICA INC.  
(630) 324-8585



Fix the EPDM assembly with the door panel by screws, washers, nuts and covers.

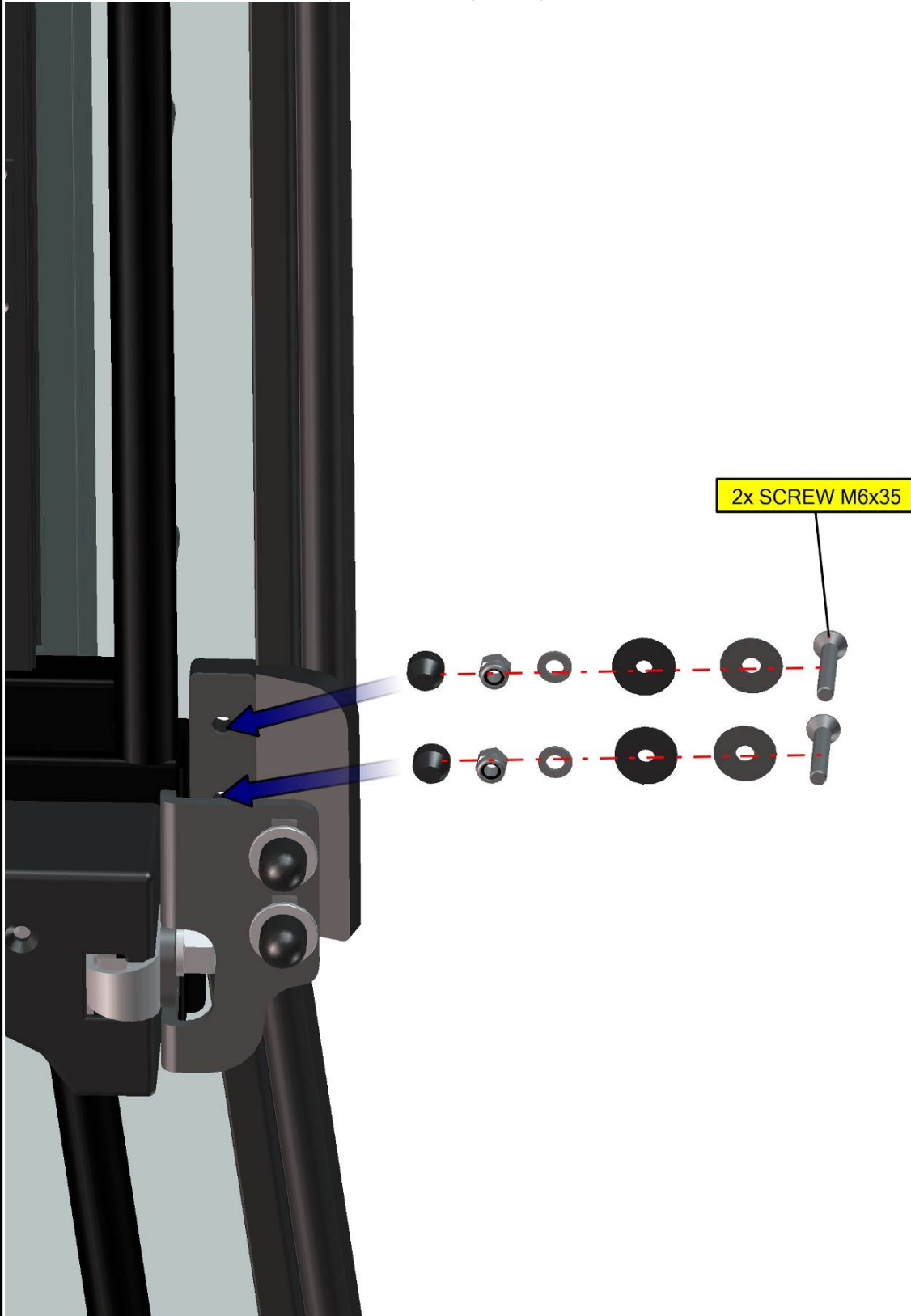

Place the EPDM onto the upper corner welded and place the upper corner onto the EPDM.



Fix the ledge and the EPDM onto the welded corner by nuts, washers and covers.

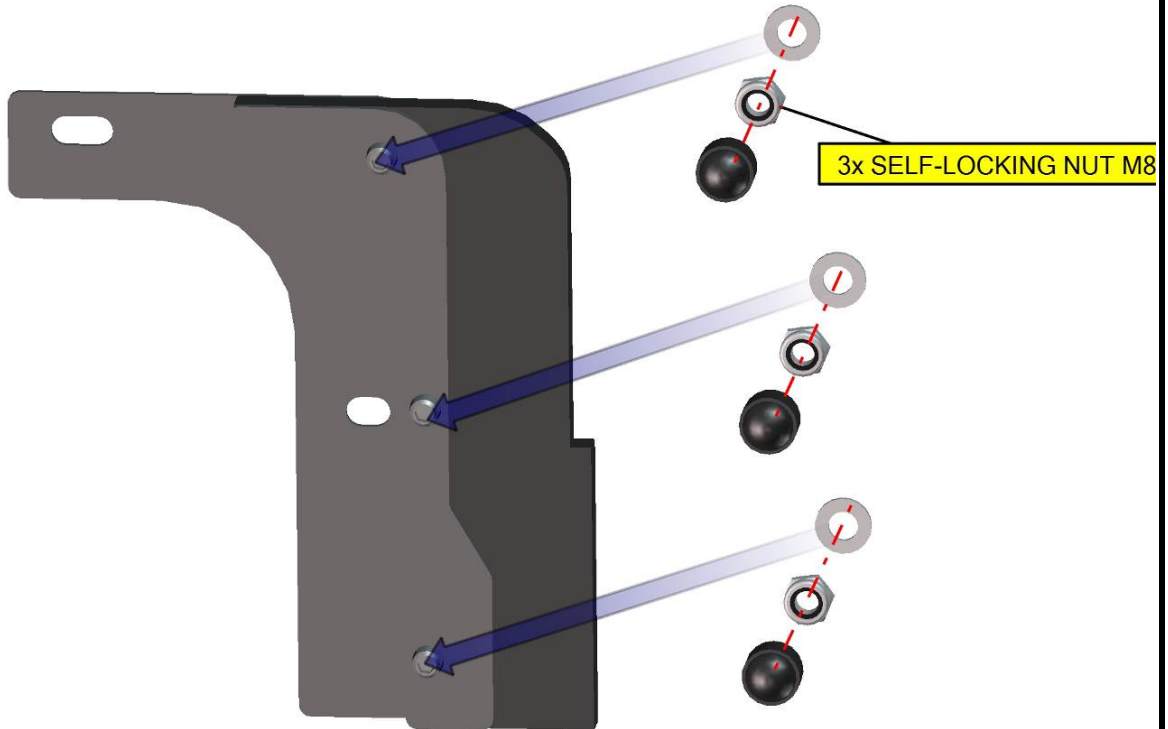

Loosen the screws from the door.



Insert the upper corner assembly between the door frame and door panel.

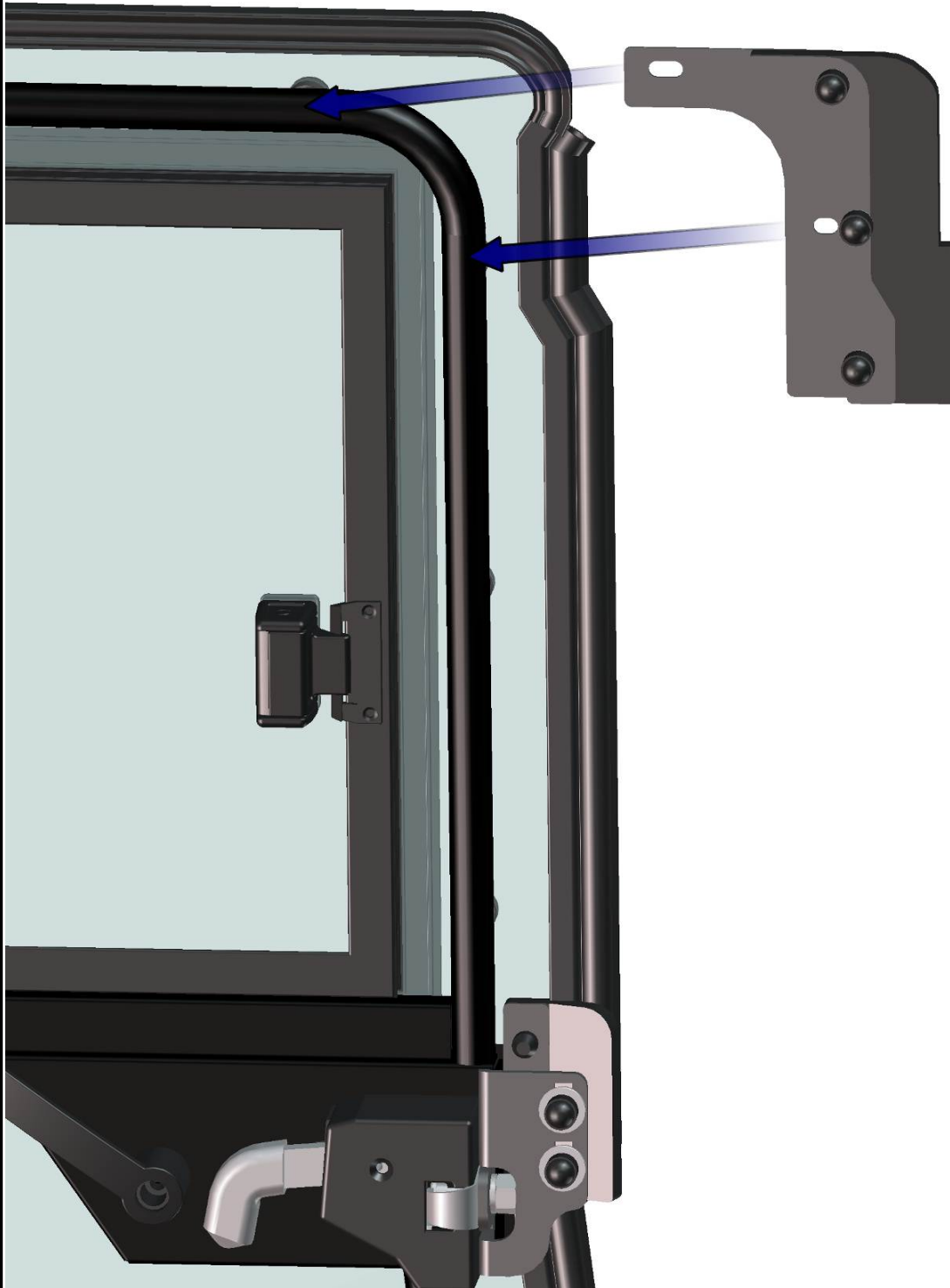

69

FOR ALL TECHNICAL QUESTIONS, PLEASE CALL  
DFK AMERICA INC.  
(630) 324-8585

Install screws back to position and tighten all screws correctly.



70

FOR ALL TECHNICAL QUESTIONS, PLEASE CALL  
DFK AMERICA INC.  
(630) 324-8585

Uninstall these screws from the door. Place the rear mirror and the mirror washer onto the door panel.  
Fix the mirror and the washer with the door by screws from previous step.

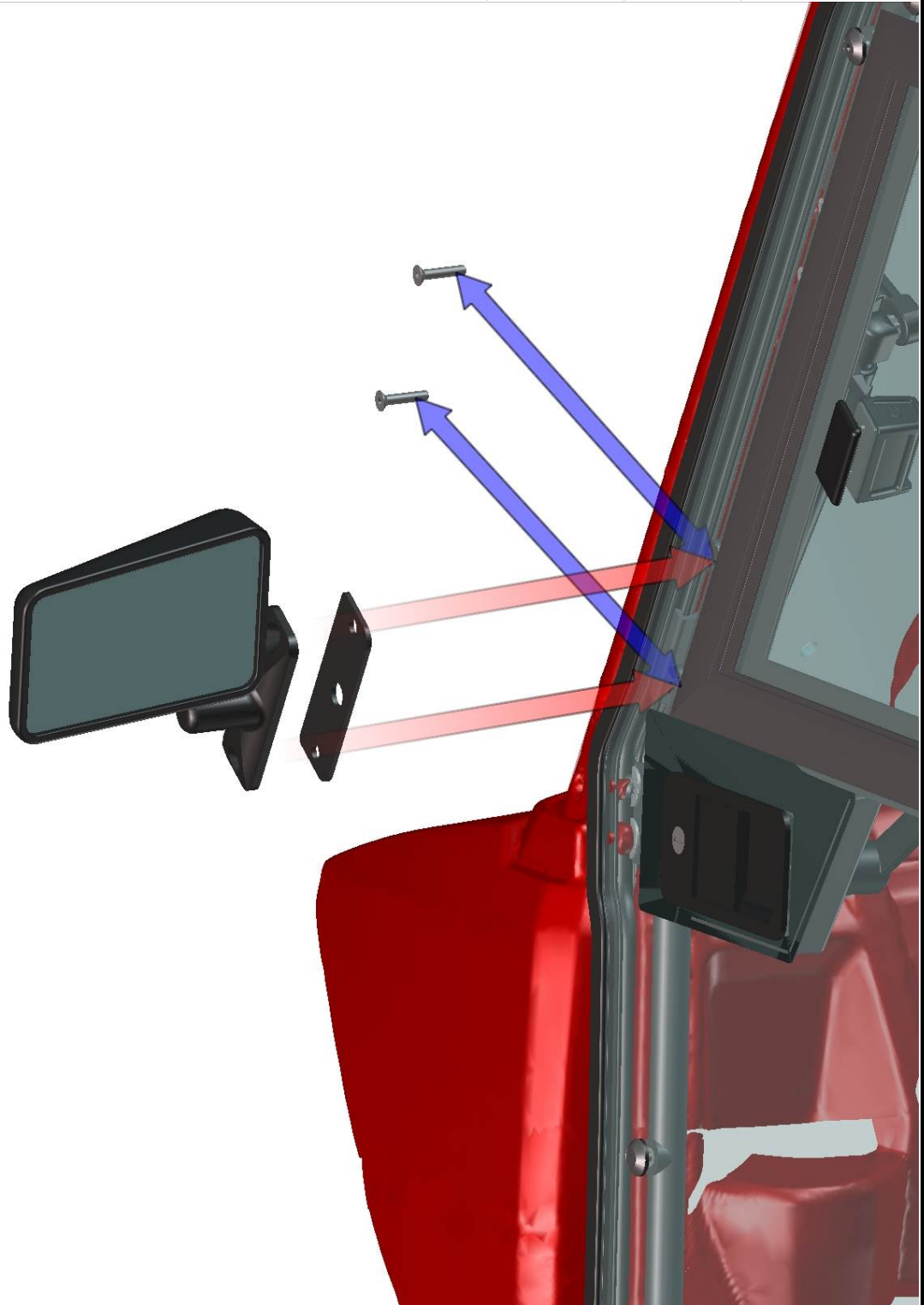

71

**The right door installation is similar,  
just repeat previous steps with right parts and assemblies.**

FOR ALL TECHNICAL QUESTIONS, PLEASE CALL  
DFK AMERICA INC.  
(630) 324-8585

**FRONT PANEL**

Uninstall original screws (in blue circles) from roller cage and instal screws M10x60 see page No.: 74. It is absolutely nessesary to make this procedure one by one, otherwise roller cage might lose its original position.

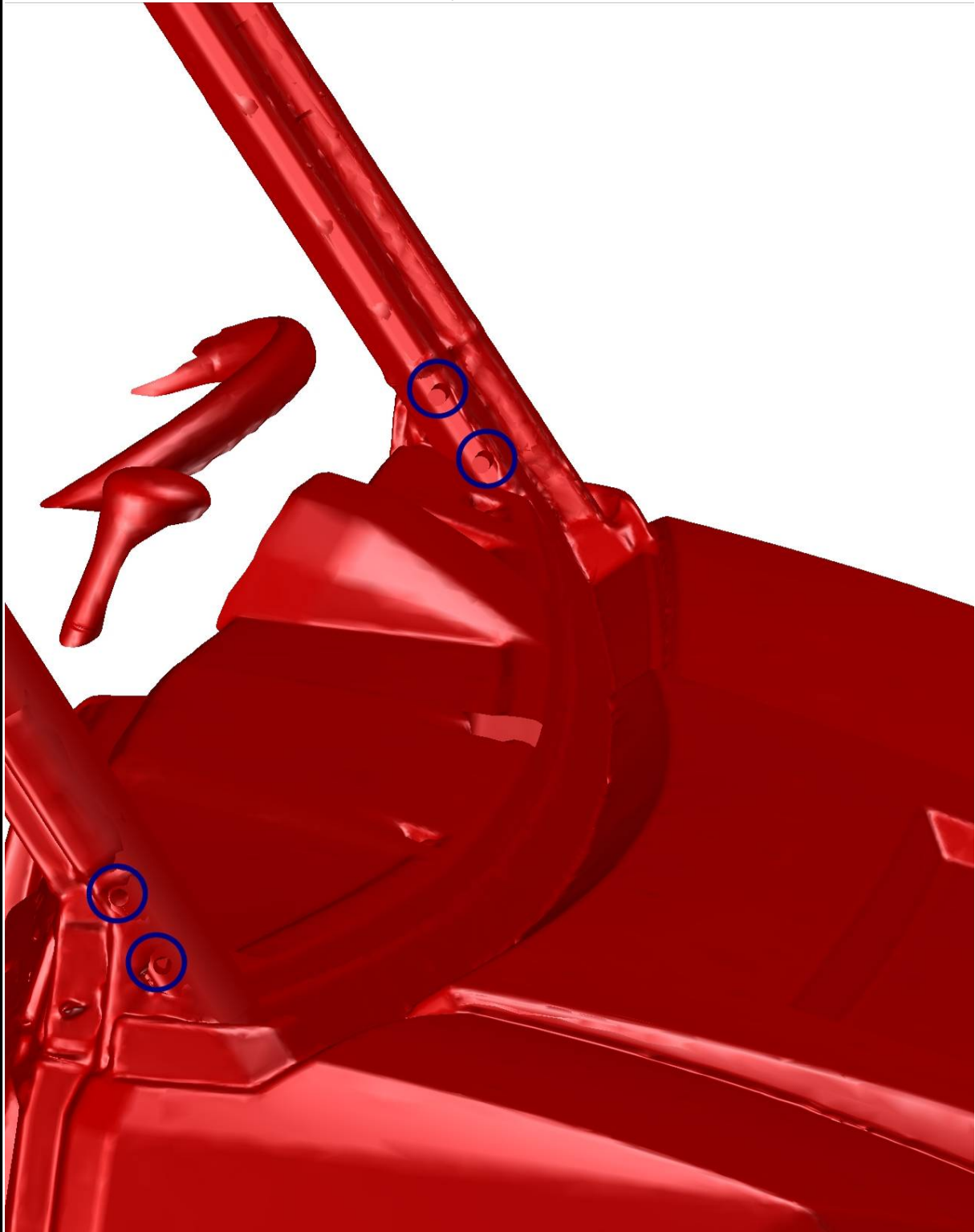

72



Place the front welded holders and front bottom ledge onto the roller cage.

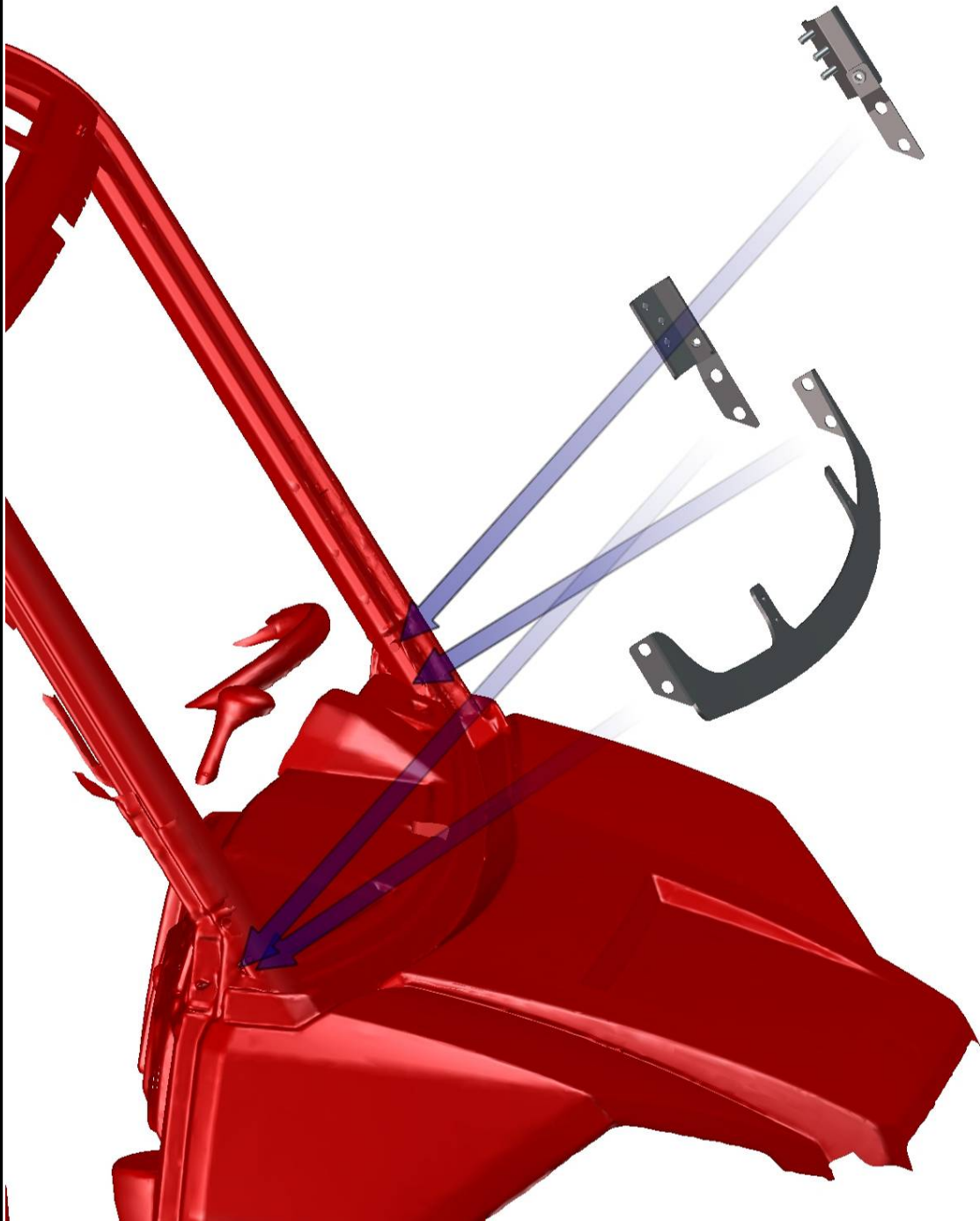

Fix the welded holder and bottom ledge with the roller cage by screws, washers, nuts and nut covers on both sides. Adjust the ledge and the holders to best position and tighten screws and nuts hard.

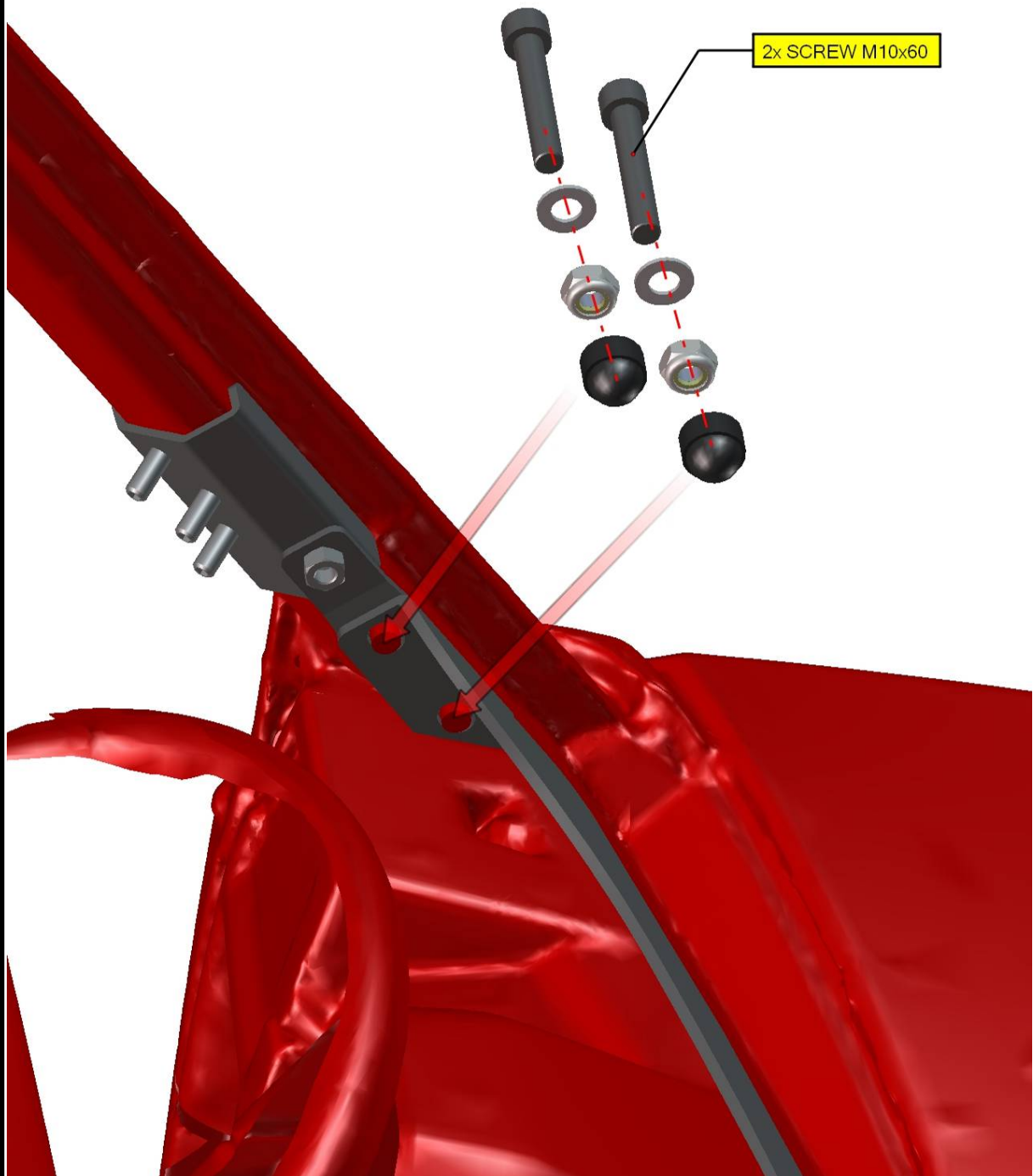

Place the front bottom outer holders onto the welded holders on both sides.

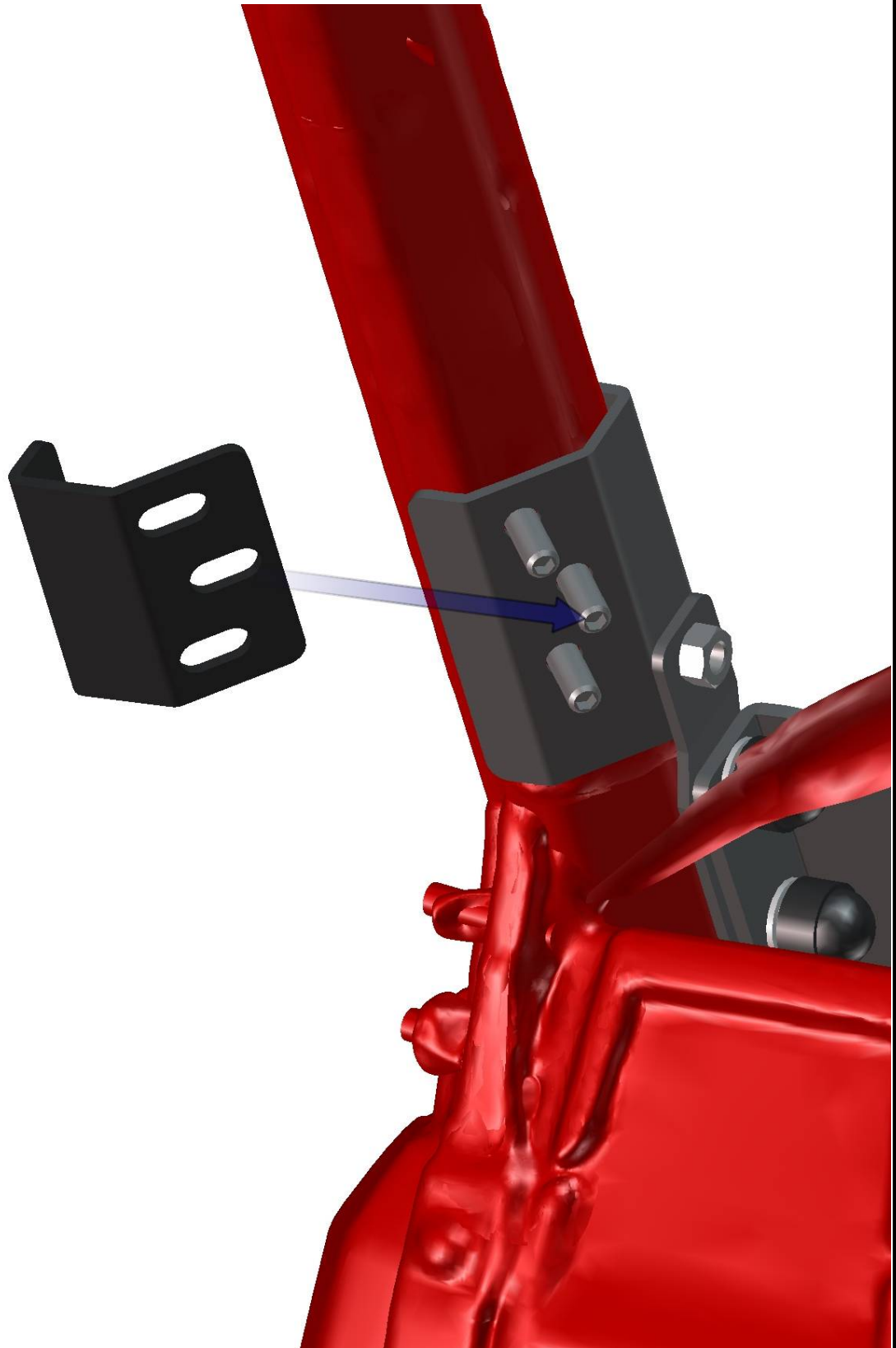

75

Fix the outer holders with the welded holders by nuts, washers and nut covers on both sides.

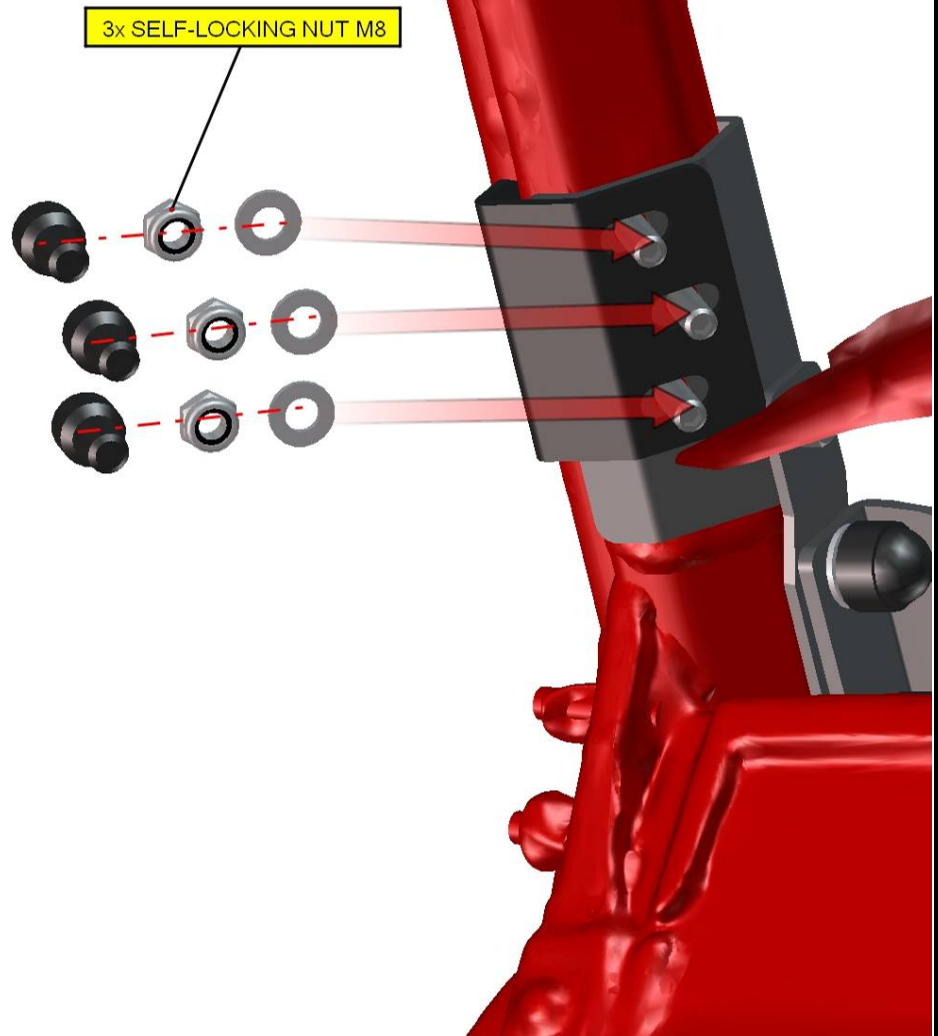

Press the holders onto the roller cage to best position and tighten nuts correctly.

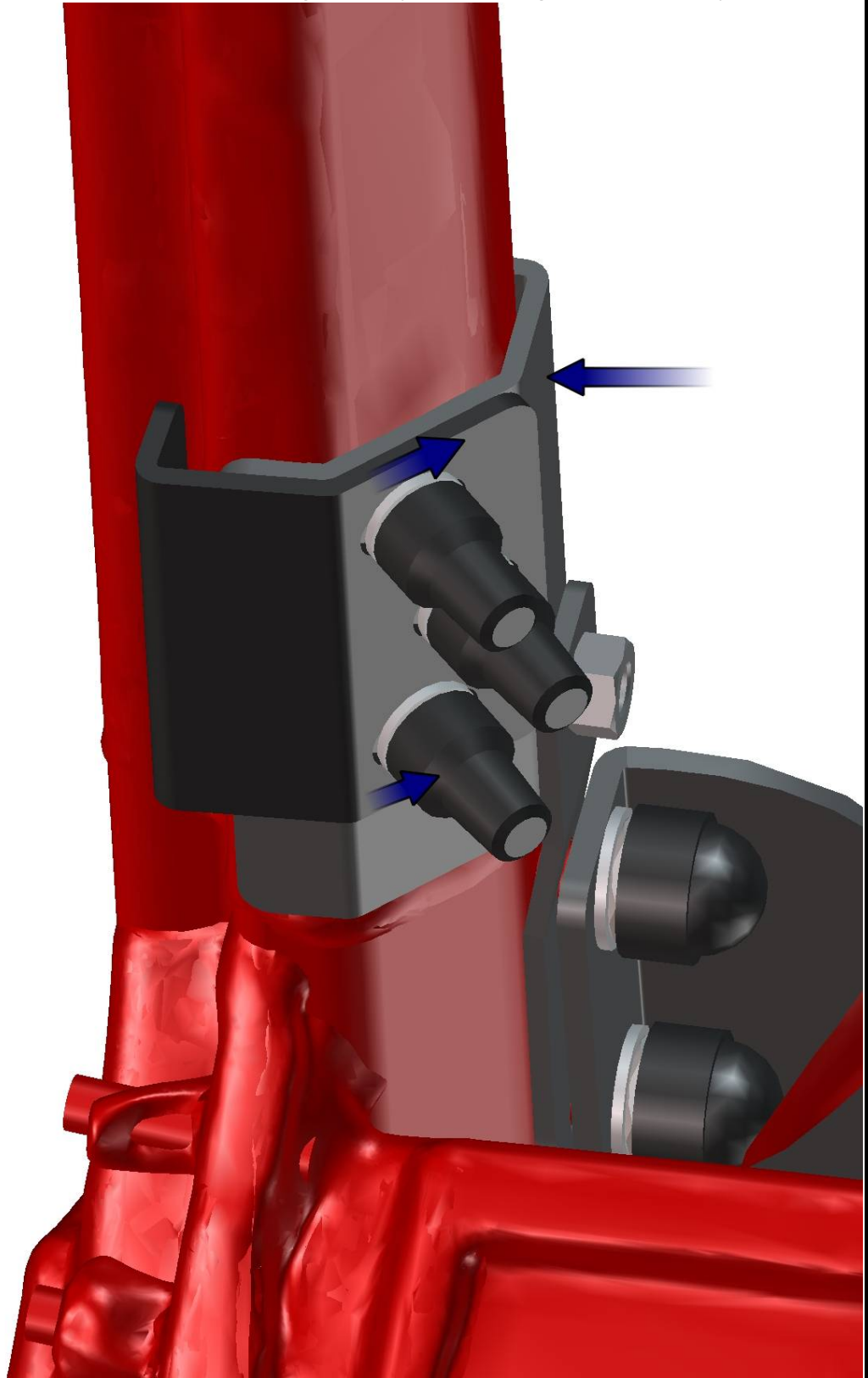

77

FOR ALL TECHNICAL QUESTIONS, PLEASE CALL  
DFK AMERICA INC.  
(630) 324-8585

**ELECTROINSTALLATION – WIPER SET**

View onto the wiper motor with the cover and with the middle ledge.



Place the washer onto the wiper longer pin.



FOR ALL TECHNICAL QUESTIONS, PLEASE CALL  
DFK AMERICA INC.  
(630) 324-8585

Place the washer onto shorter wiper pin.



View onto installed washers.



FOR ALL TECHNICAL QUESTIONS, PLEASE CALL  
DFK AMERICA INC.  
(630) 324-8585

Place the wiper assembly onto the front glass from inner side.  
Insert these washers onto the wiper's pins and onto the glass from outer side.



Fix the wiper motor with the front glass by included nuts and tighten these correctly.





**FRONT PANEL**

Place the front panel with the hinges onto the roller cage's roof in accordance with the original holes.



81

Fix the front hinges with the roller cage by screws, washers, nuts and nut covers.  
**Adjust the front glass to best position** and tighten these screws and nuts hard.  
Spray silicone from outer side into the roller cage gaps (in green circle) in both sides of UTV.

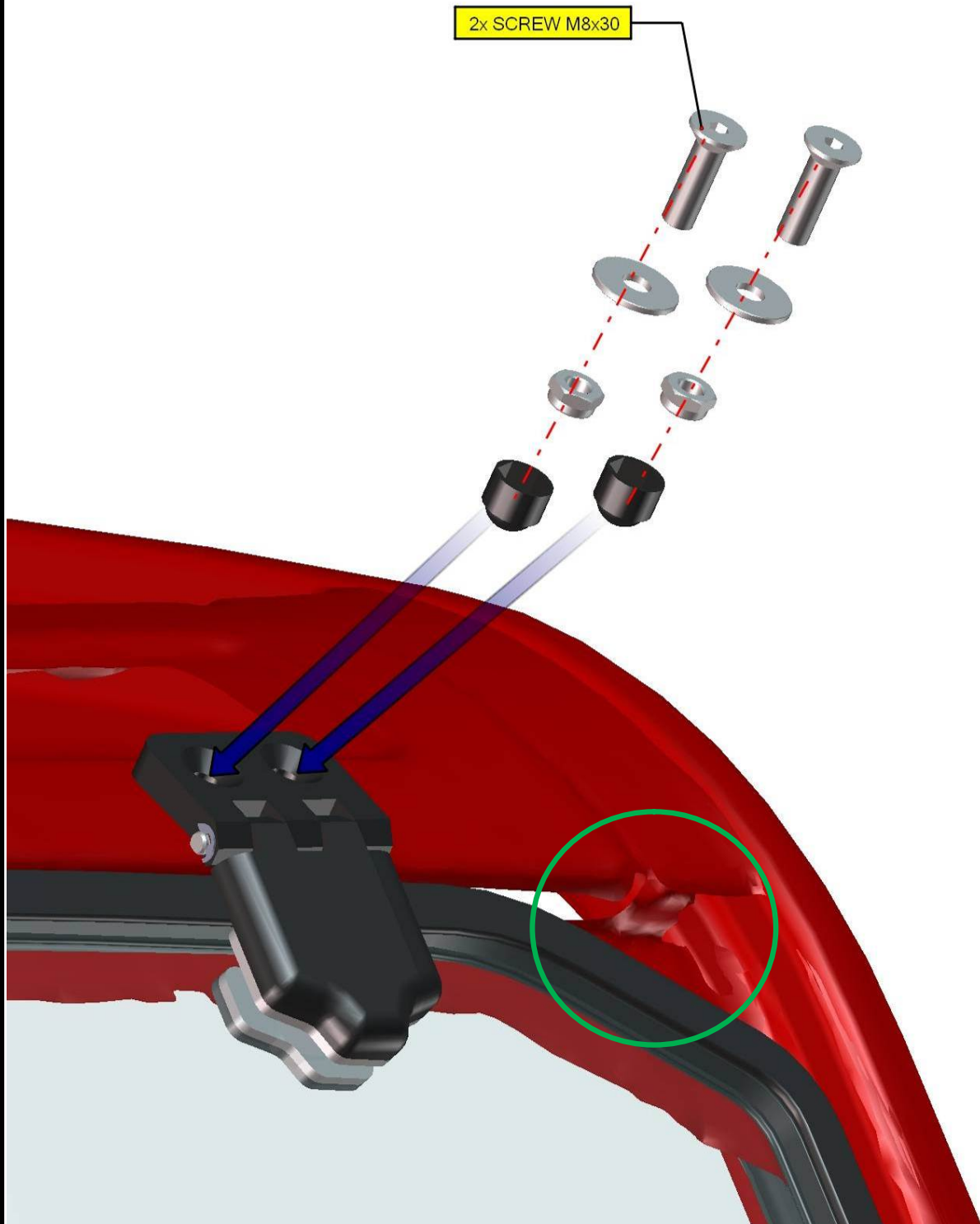

Install the gas spring into the gas spring holders.

*IT IS IMPORTANT TO INSTALL GAS SPRING IN SAME ORIENTATION LIKE IN PICTURE*



83

FOR ALL TECHNICAL QUESTIONS, PLEASE CALL  
DFK AMERICA INC.  
(630) 324-8585

Adjust the glass lock to correct position and fix that by included pin on both sides.

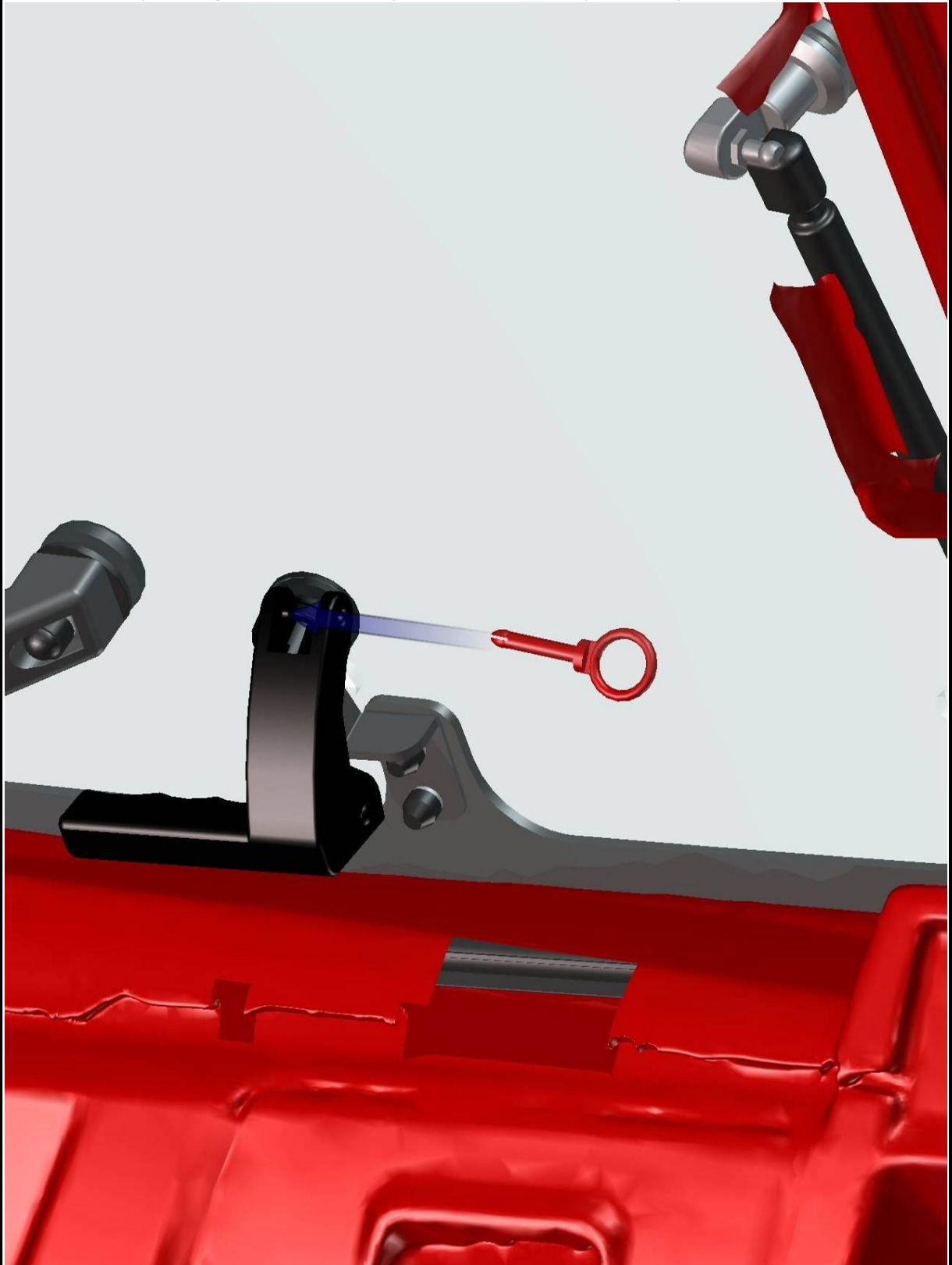

84

FOR ALL TECHNICAL QUESTIONS, PLEASE CALL  
DFK AMERICA INC.  
(630) 324-8585

If you face any gaps between the front glass sealing and roller cage, you can use second sealing for front panel (included).



85

SEE NEXT PAGE

FOR ALL TECHNICAL QUESTIONS, PLEASE CALL  
DFK AMERICA INC.  
(630) 324-8585

Detail view



**ELECTROINSTALLATION step 2.**

Lead the harness branch No.: 1 around the roller cage to the front wiper motor.



Connect the harness branch with the wiper motor connector.

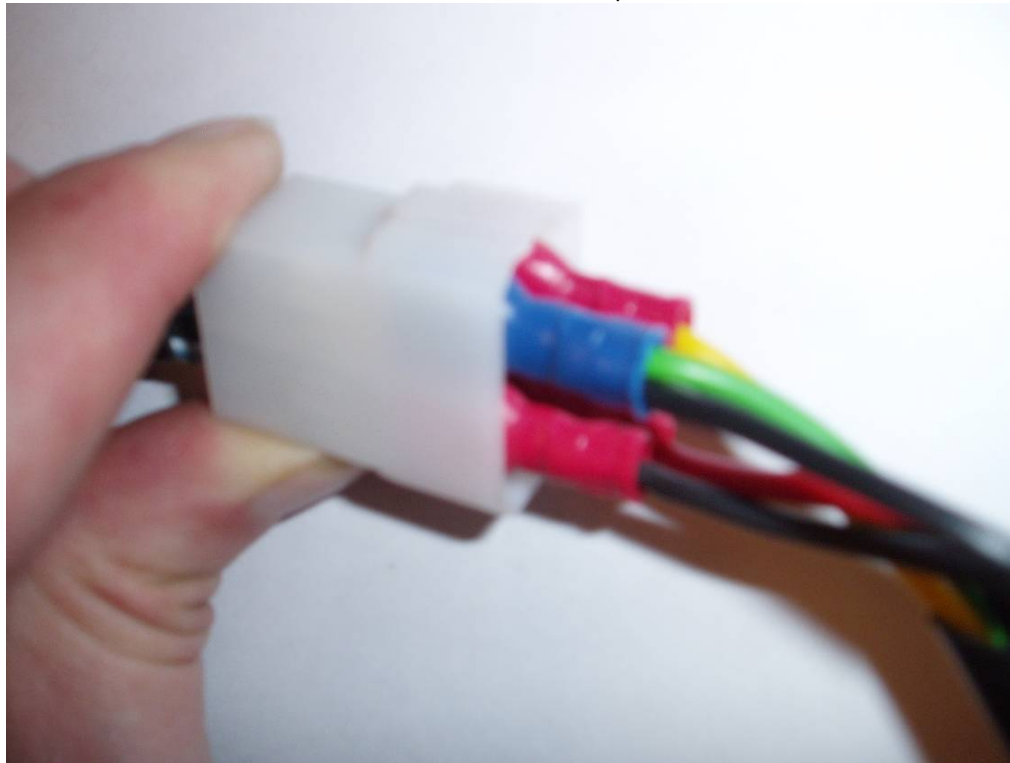

FOR ALL TECHNICAL QUESTIONS, PLEASE CALL  
DFK AMERICA INC.  
(630) 324-8585

Now you can turn on wiper switch and look on the larger wiper pin.  
If you connect all harness connectors correctly, pin is turning. Find the ends of turning and install the wiper arm on correct position.



Fix the wiper arm with the wiper motor pin by included nut.  
Insert plastic holder onto the wiper latch pin in correct position



FOR ALL TECHNICAL QUESTIONS, PLEASE CALL  
DFK AMERICA INC.  
(630) 324-8585



View onto the installed plastic holder.



Insert the wiper arm hook onto the wiper latch plastic holder and press it into the correct position.



FOR ALL TECHNICAL QUESTIONS, PLEASE CALL  
DFK AMERICA INC.  
(630) 324-8585

View onto installed wiper arm hook.



Connect the washer hose from the harness with the washer hose from wiper arm by included tube.



FOR ALL TECHNICAL QUESTIONS, PLEASE CALL  
DFK AMERICA INC.  
(630) 324-8585

REAR PANEL

Insert the rear bottom ledge onto the rear bottom UTV's wall and adjust to correct position.

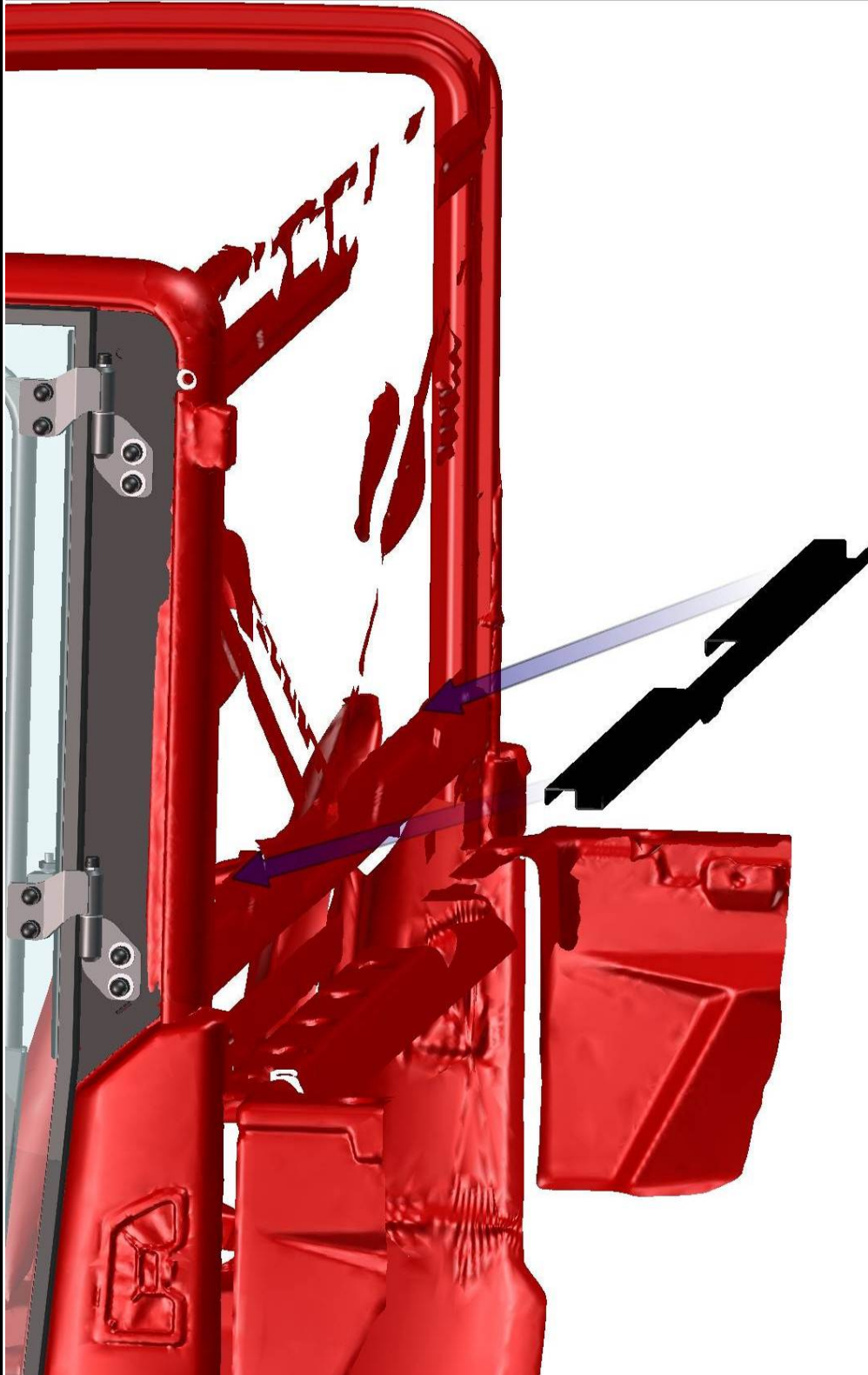

Place the rear glass holders onto the rear glass.

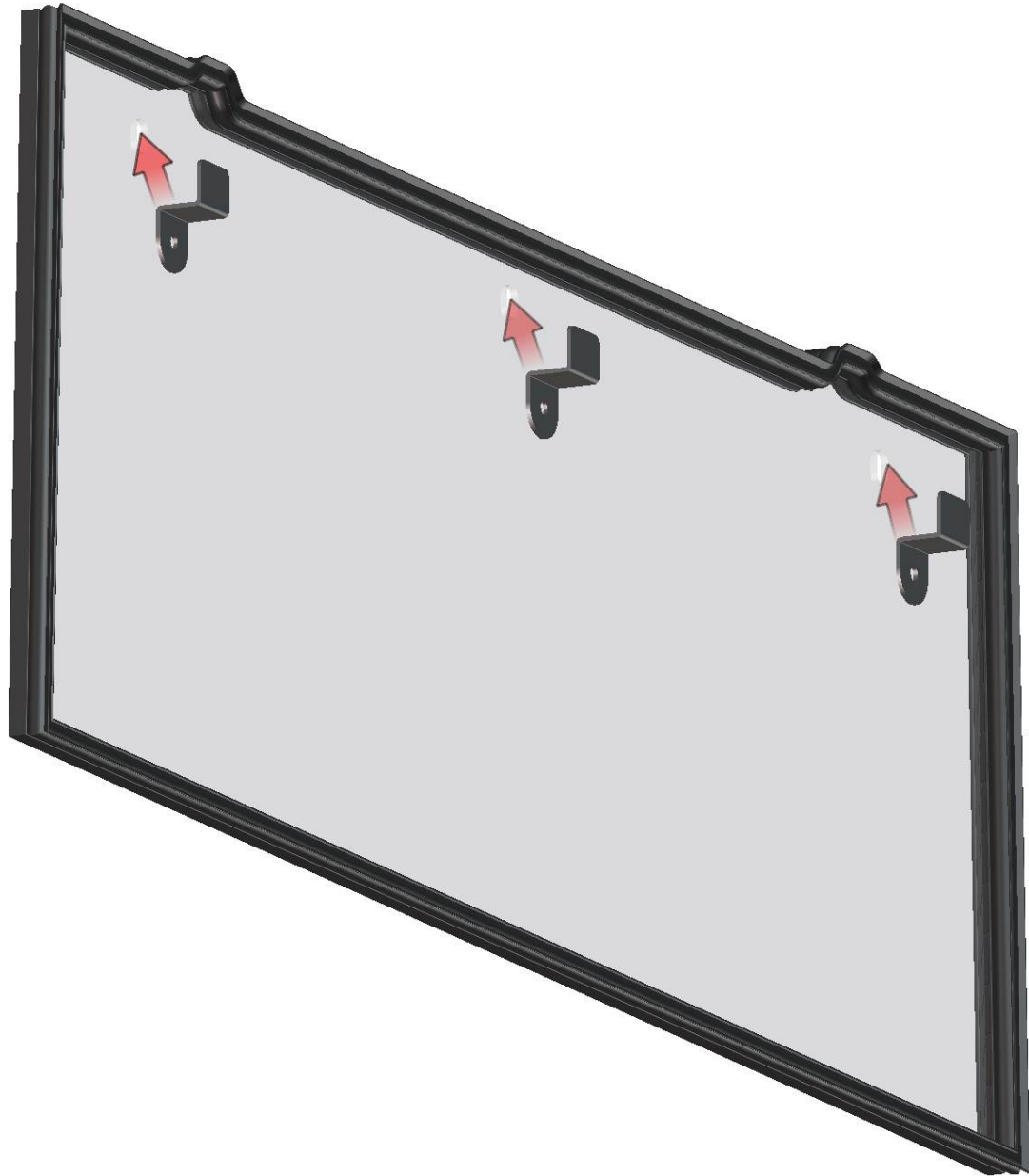

Install the screws and washers into the rear glass from outer side.

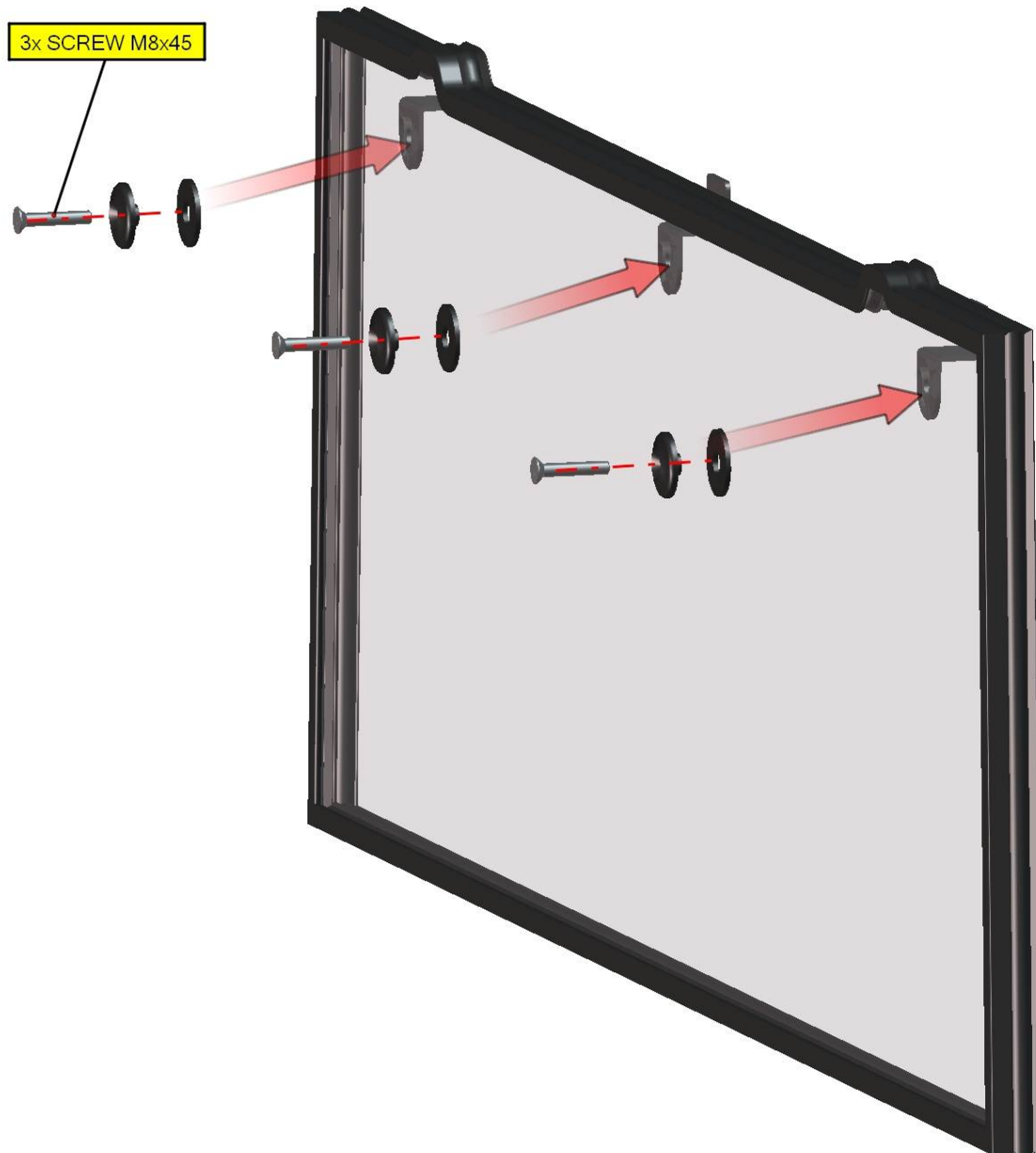

Fix the glass with the holders by screws and fast-lock handles and don't tighten these.

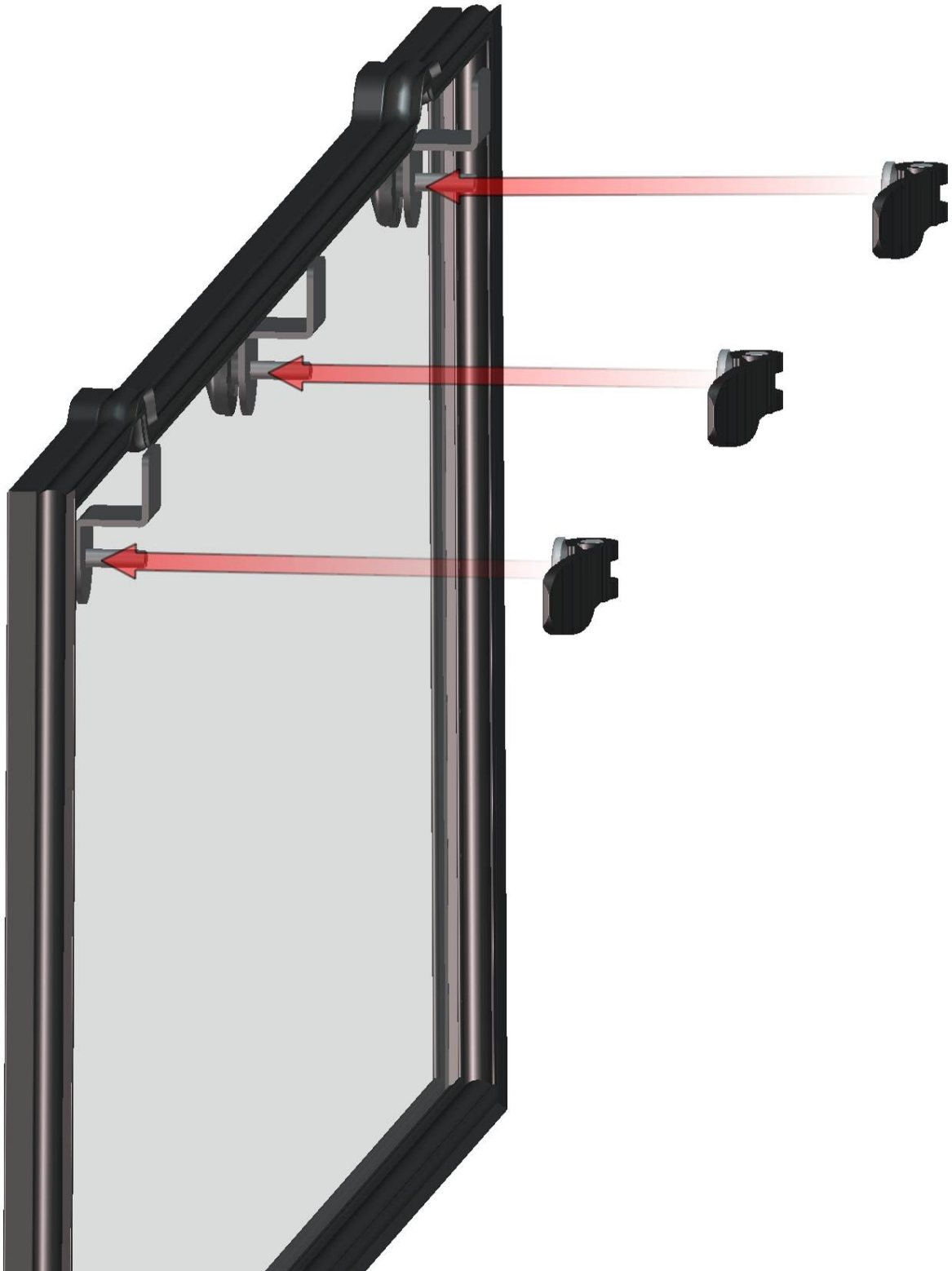

Place the rear panel into the rear ledge and onto the roller cage.

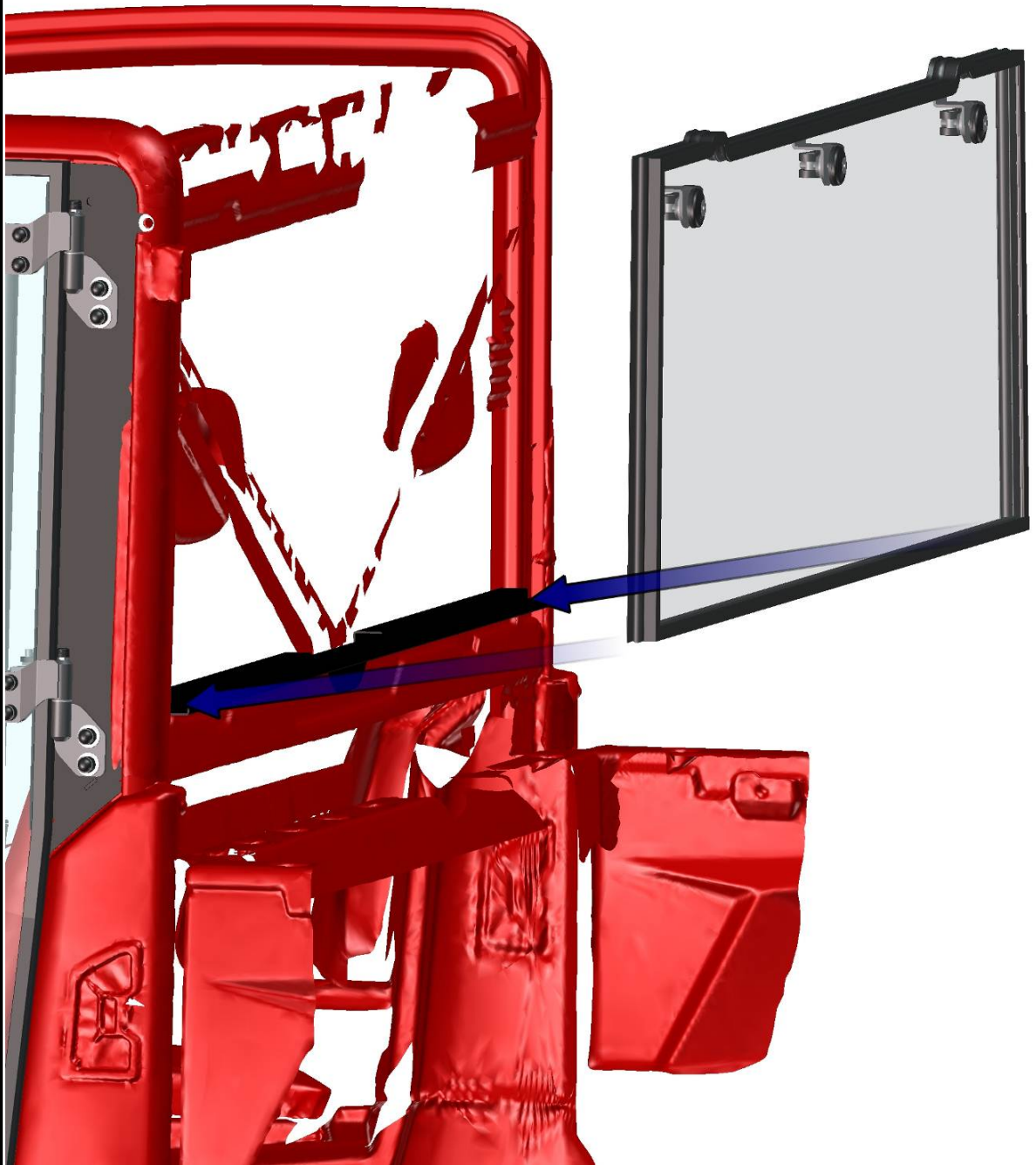

95

FOR ALL TECHNICAL QUESTIONS, PLEASE CALL  
DFK AMERICA INC.  
(630) 324-8585

Fast-lock assembly (explode view).

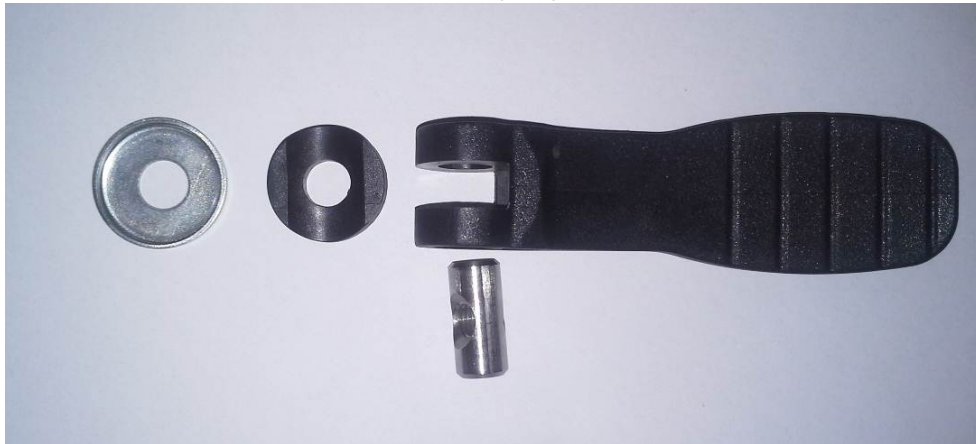

Fast-lock handle mounted.



Fast-lock handle tightened.



FOR ALL TECHNICAL QUESTIONS, PLEASE CALL  
DFK AMERICA INC.  
(630) 324-8585



Adjust the rear glass and the holders to best position and tighten fast-lock handles.

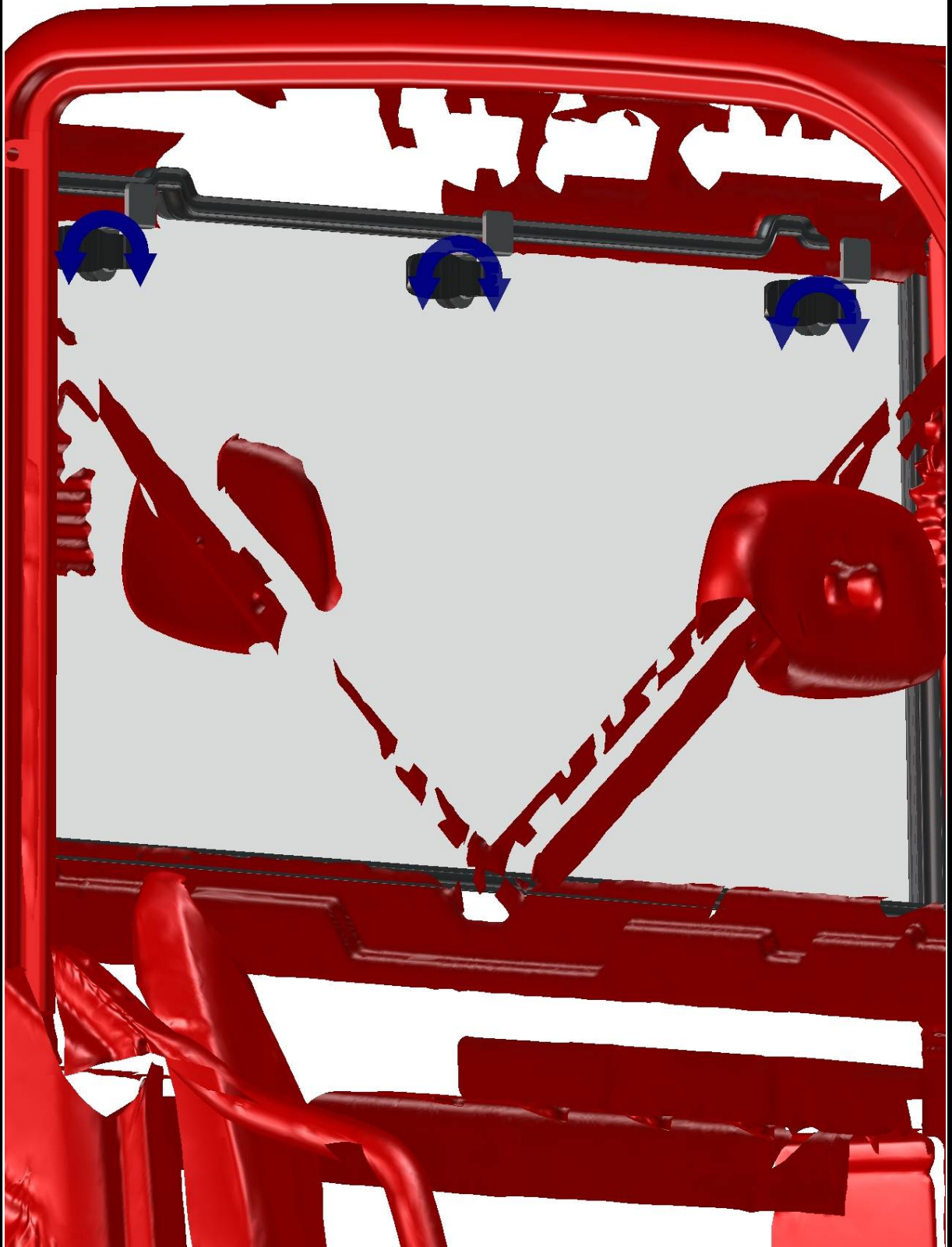

**ROOF**

Place the rear roof reinforcement onto the roller cage.



98

Insert the holders into the reinforcement's rectangle holes and onto the roller cage.

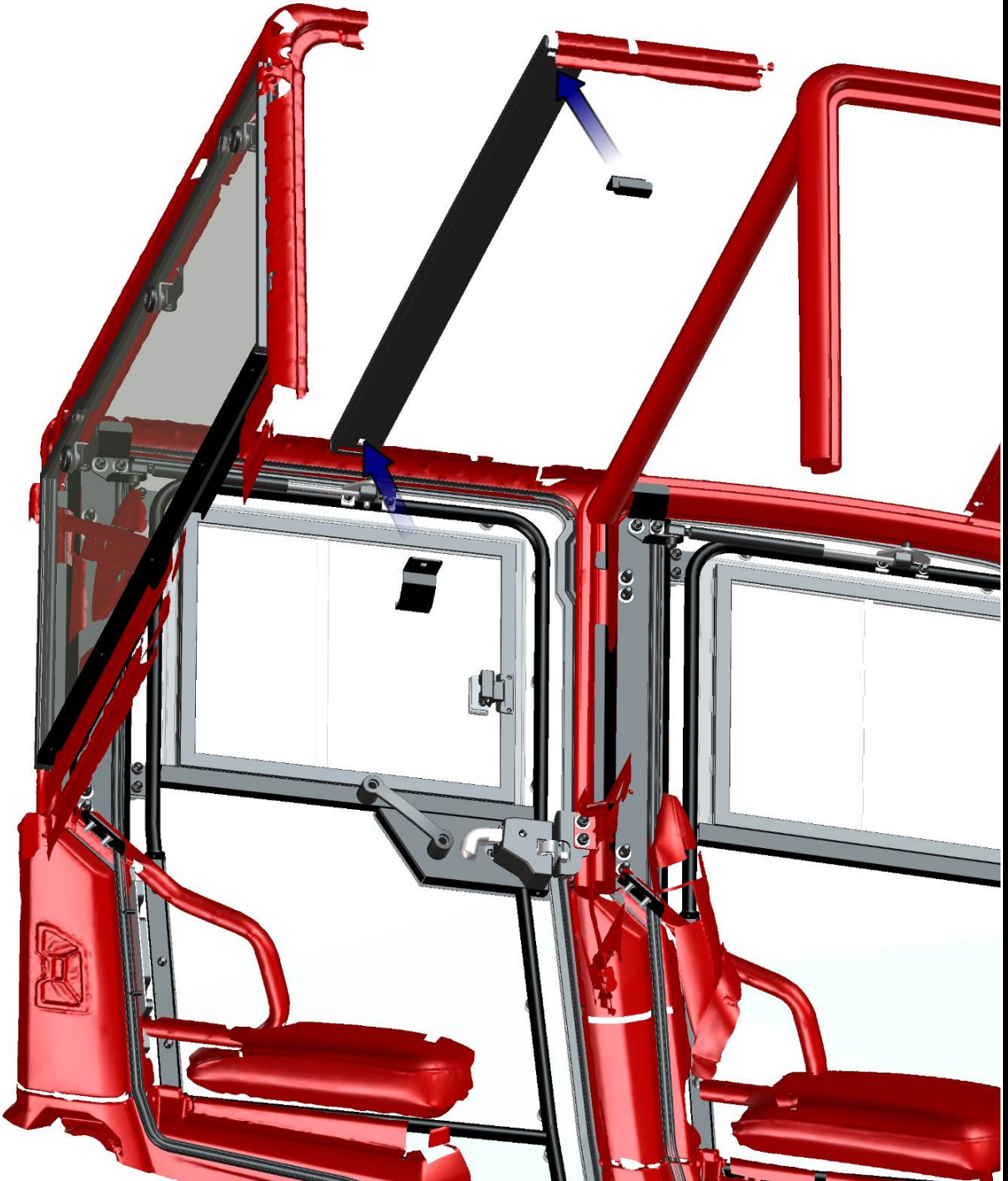

99

FOR ALL TECHNICAL QUESTIONS, PLEASE CALL  
DFK AMERICA INC.  
(630) 324-8585

Fix the reinforcement with the holders to the roller cage by screws, washers, nuts and covers.



FOR ALL TECHNICAL QUESTIONS, PLEASE CALL  
DFK AMERICA INC.  
(630) 324-8585

Place the second roof reinforcement onto the roof frame.



101

FOR ALL TECHNICAL QUESTIONS, PLEASE CALL  
DFK AMERICA INC.  
(630) 324-8585

Place the rear roof onto the roller cage and adjust to best position.

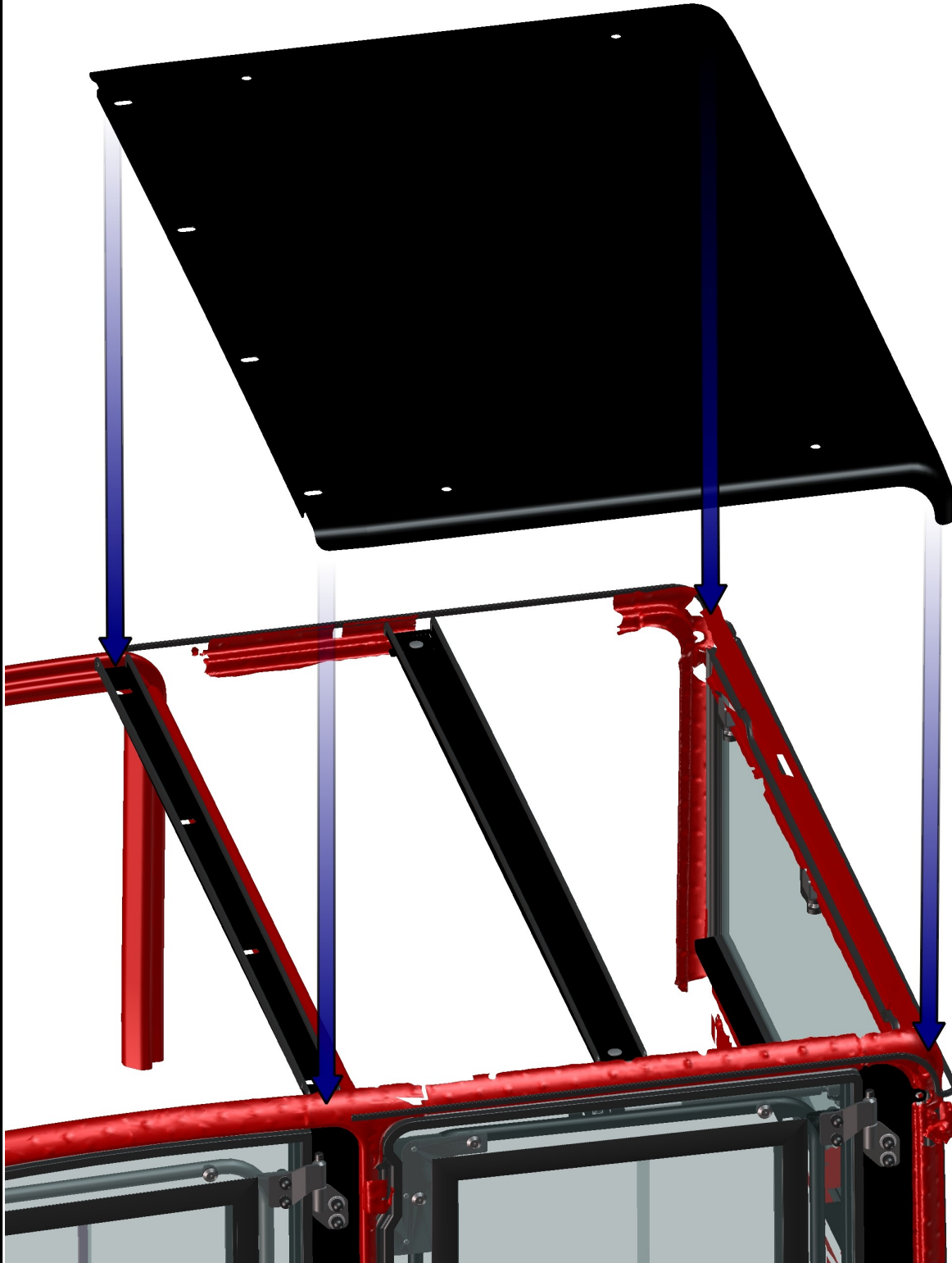

102

FOR ALL TECHNICAL QUESTIONS, PLEASE CALL  
DFK AMERICA INC.  
(630) 324-8585

Place the front roof onto the roller cage and onto the rear roof and adjust to best position.

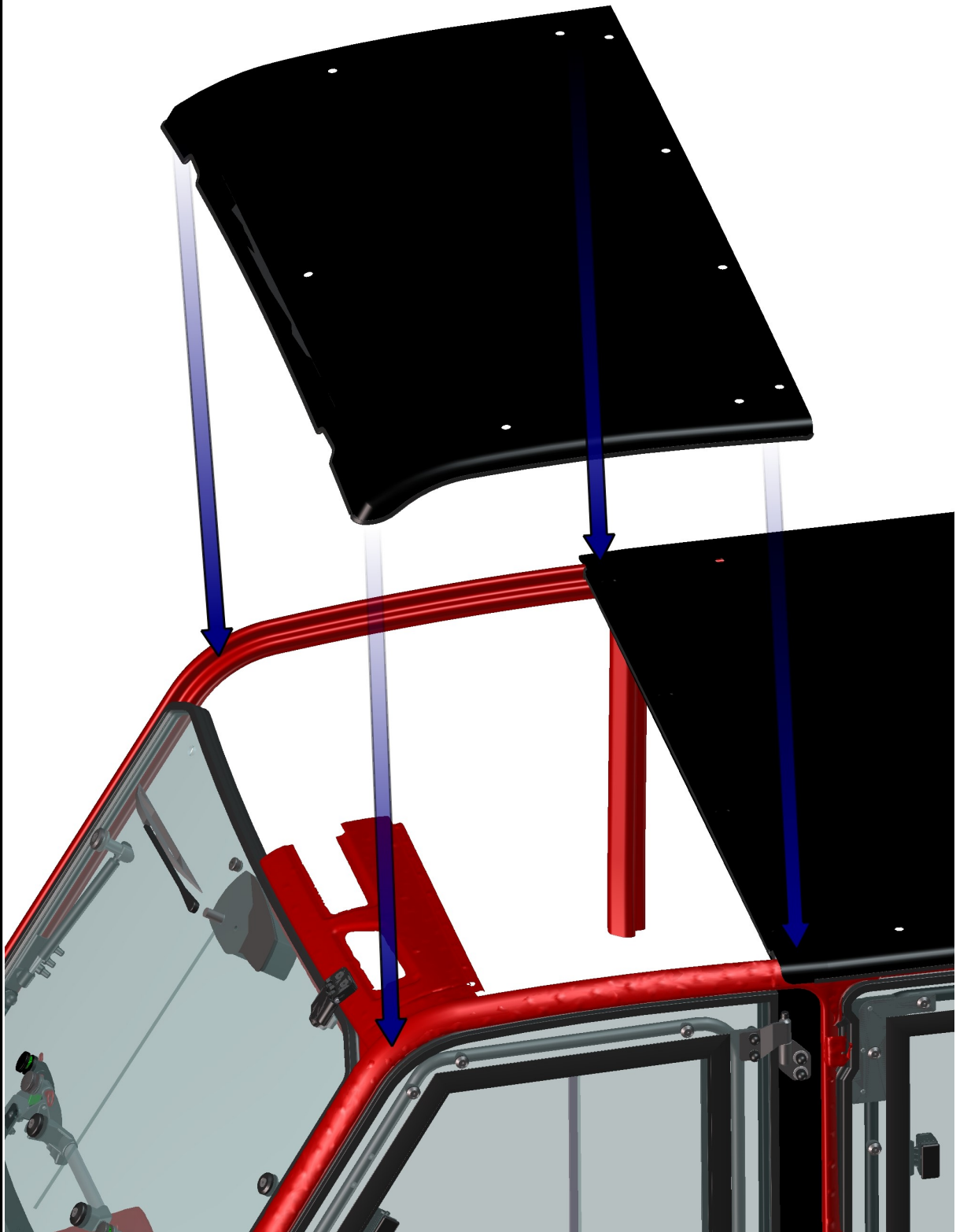

FOR ALL TECHNICAL QUESTIONS, PLEASE CALL  
DFK AMERICA INC.  
(630) 324-8585

Place the holders onto the front roof and onto the roller cage on both sides.

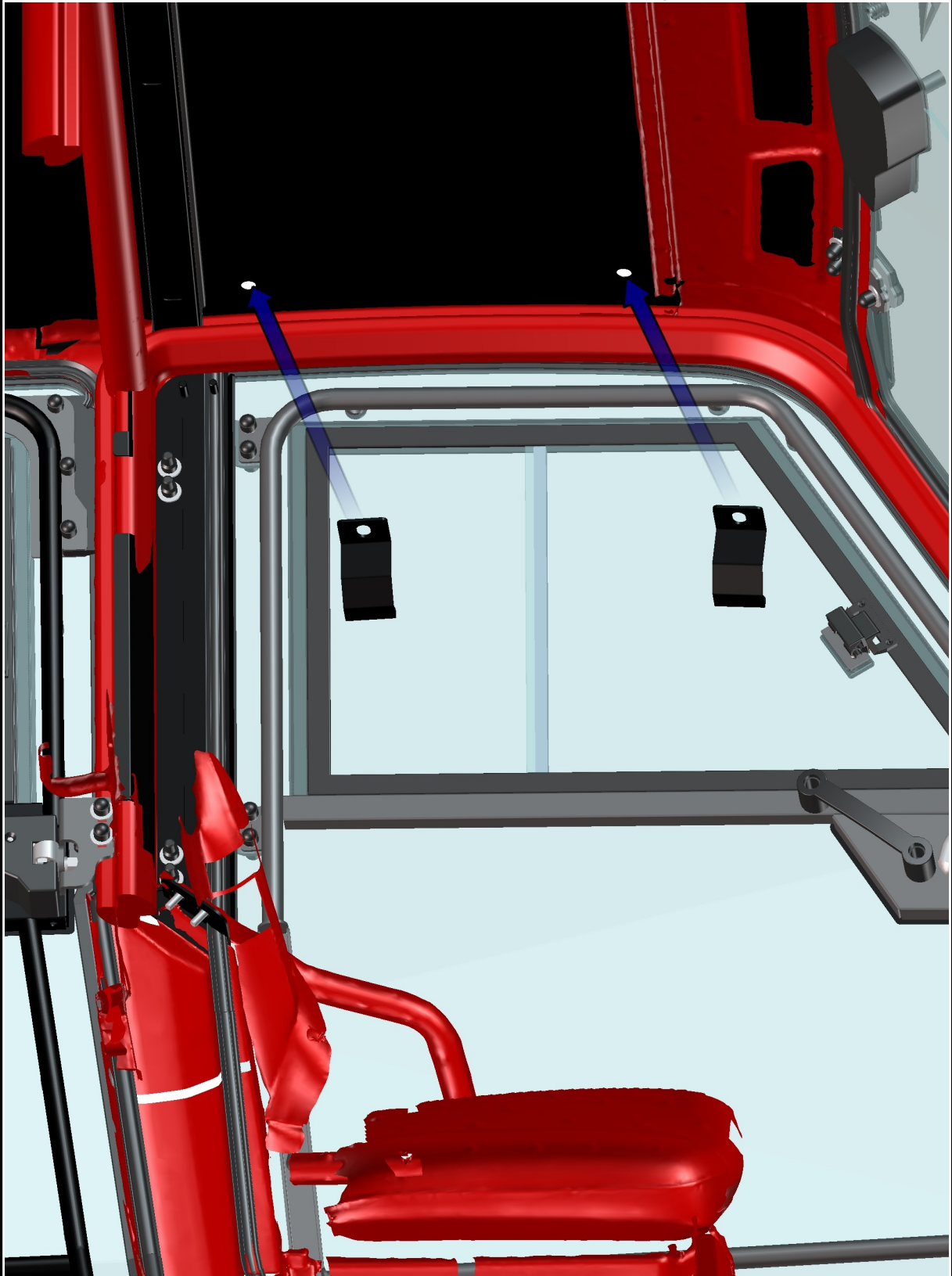

104

FOR ALL TECHNICAL QUESTIONS, PLEASE CALL  
DFK AMERICA INC.  
(630) 324-8585



Fix the holders with the roof and with the roller cage by screws, washers, nuts and covers on both sides.

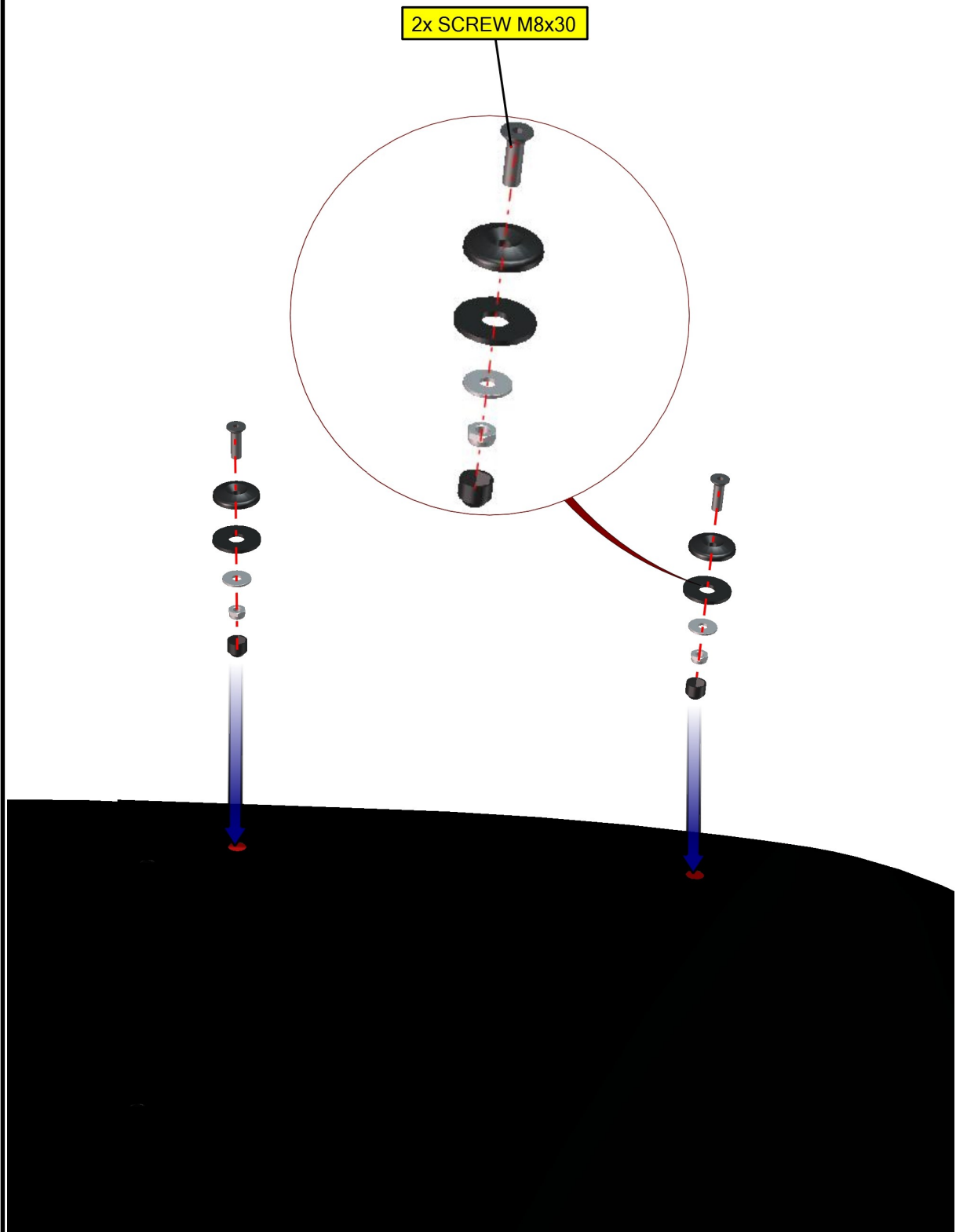

105

Place the front roof holder onto the roof and onto the roller cage.



106

FOR ALL TECHNICAL QUESTIONS, PLEASE CALL  
DFK AMERICA INC.  
(630) 324-8585

Fix the holder with the roof to the roller cage by screw, washers, nut and cover.

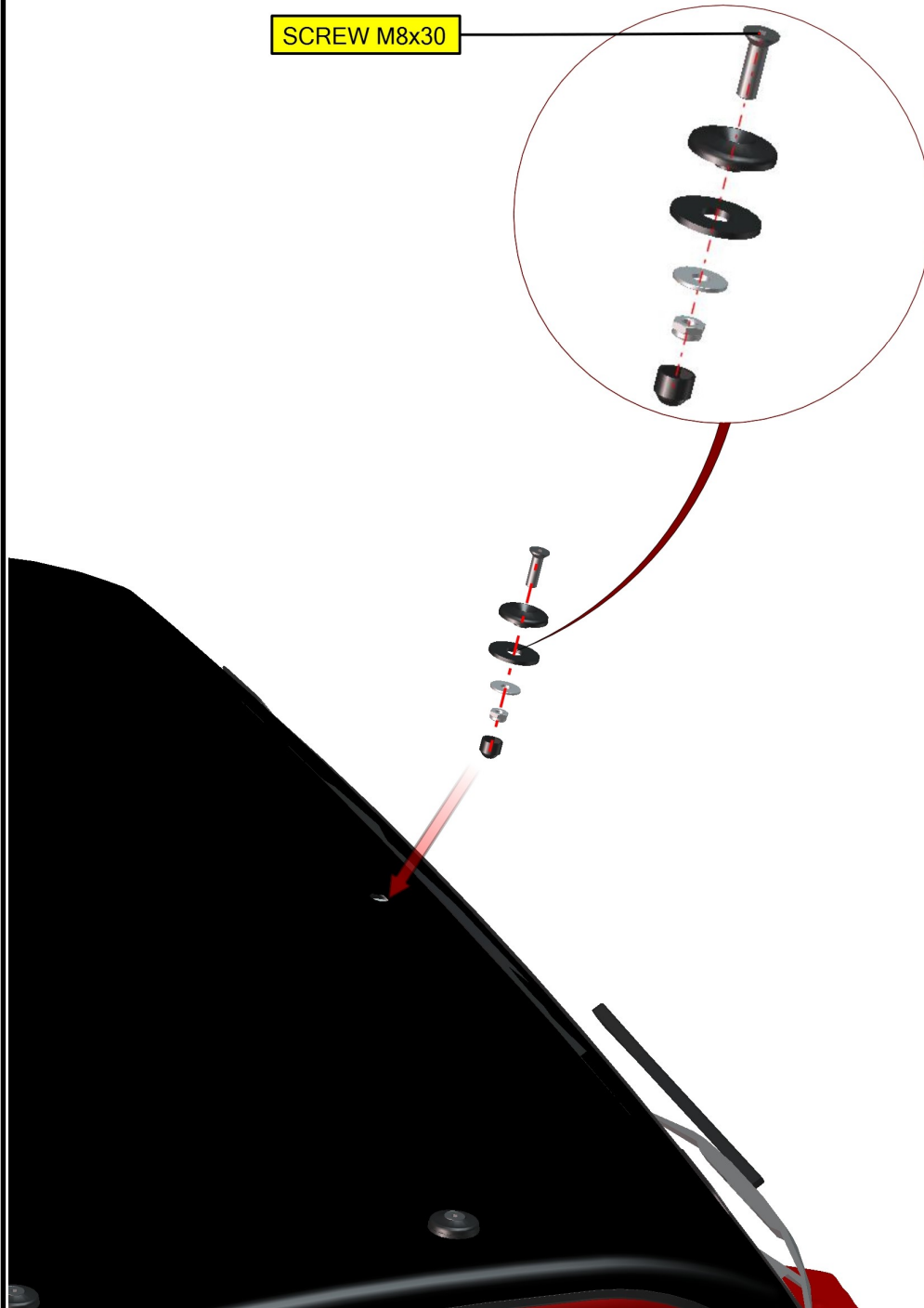

107

FOR ALL TECHNICAL QUESTIONS, PLEASE CALL  
DFK AMERICA INC.  
(630) 324-8585

Place the holders onto the rear roof and onto the roller cage on both sides.

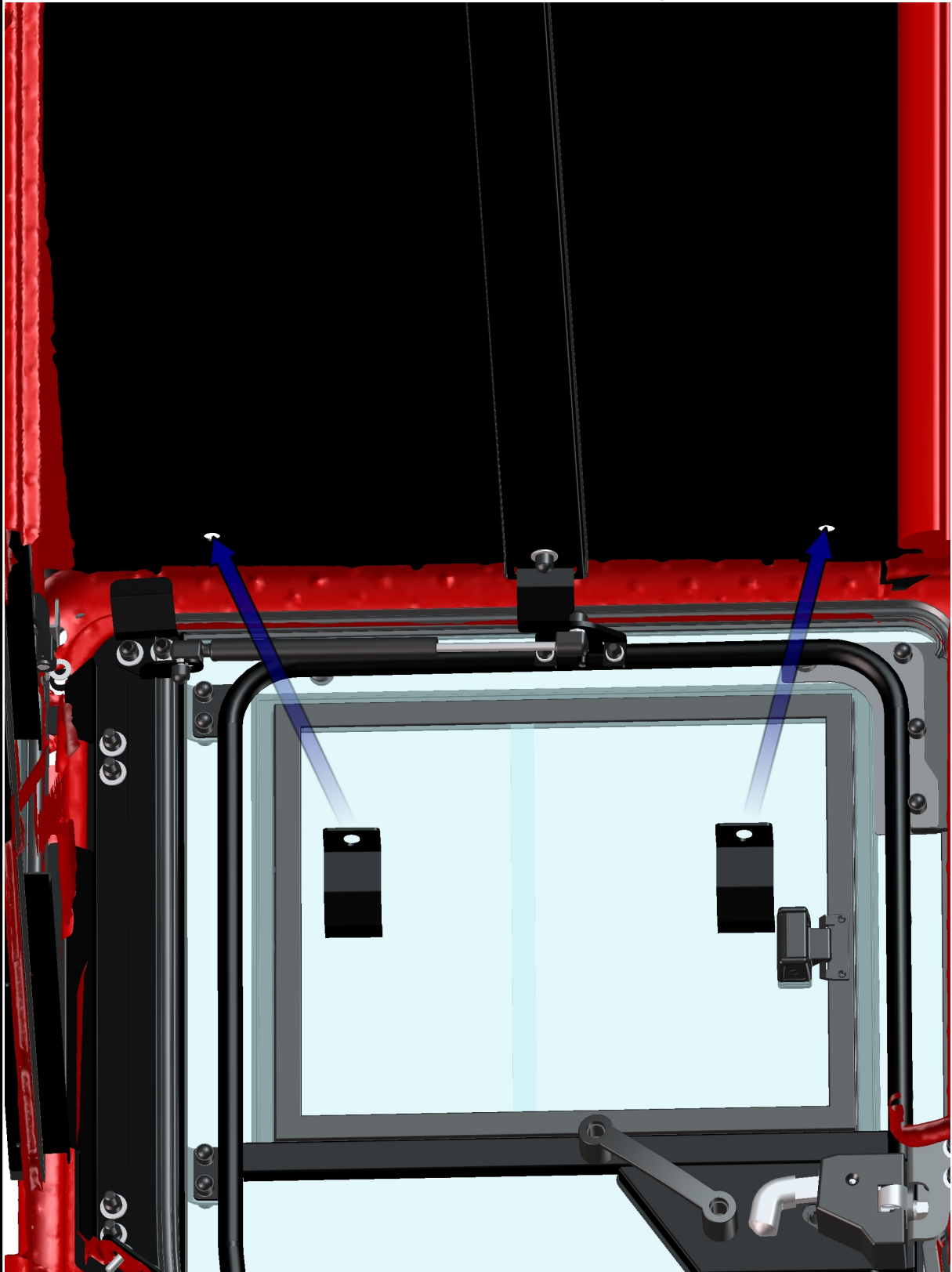

108

FOR ALL TECHNICAL QUESTIONS, PLEASE CALL  
DFK AMERICA INC.  
(630) 324-8585

Fix the holders with the roof to the roller cage by screws, washers, nuts and covers on both sides.

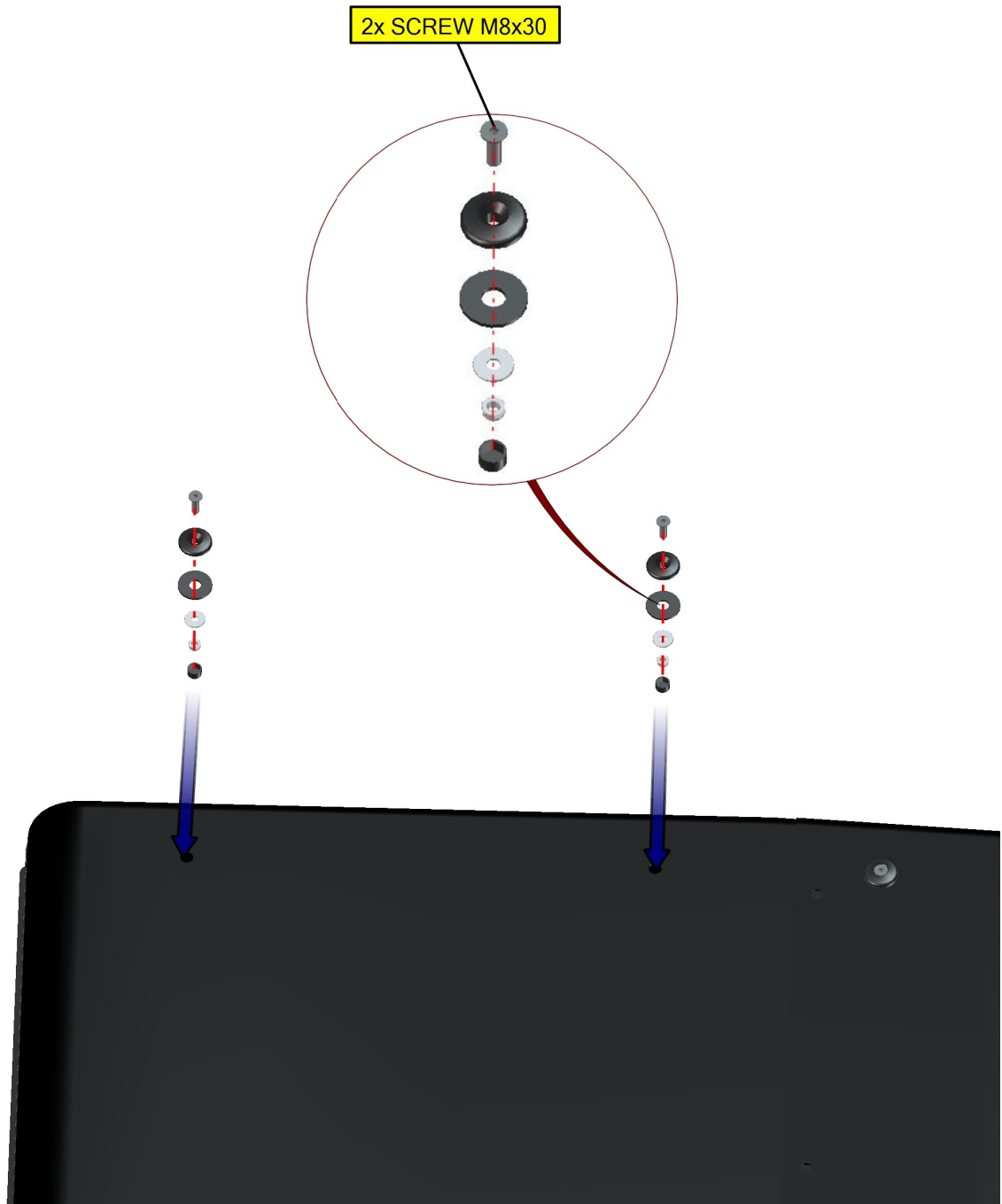

Fix the front roof with the rear roof by screws, washers, nuts and covers.

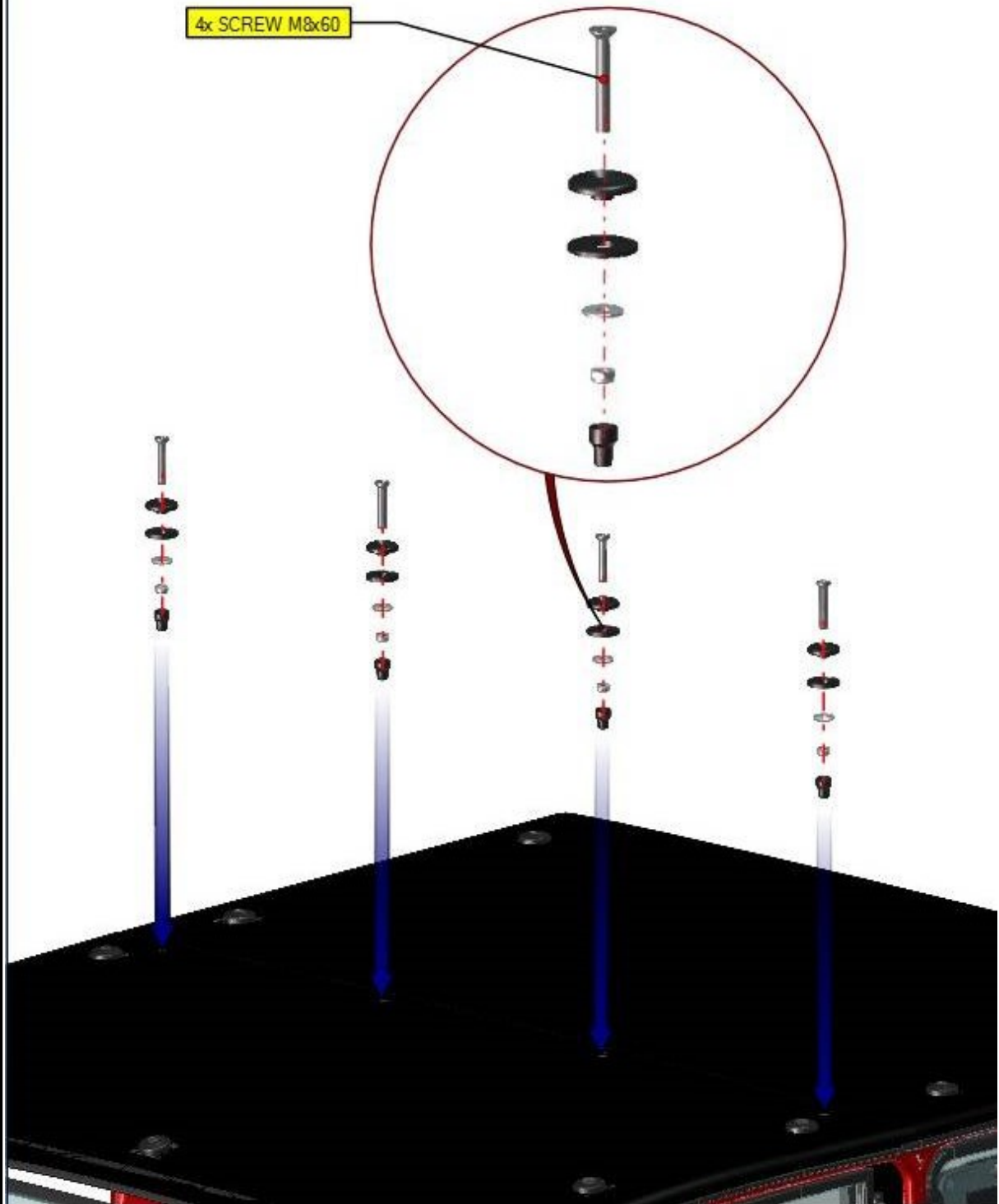

110

Adjust the roofs to the best positions and tighten screws and nuts correctly.

FOR ALL TECHNICAL QUESTIONS, PLEASE CALL  
DFK AMERICA INC.  
(630) 324-8585

Spray silicon (included) into the roof connection.

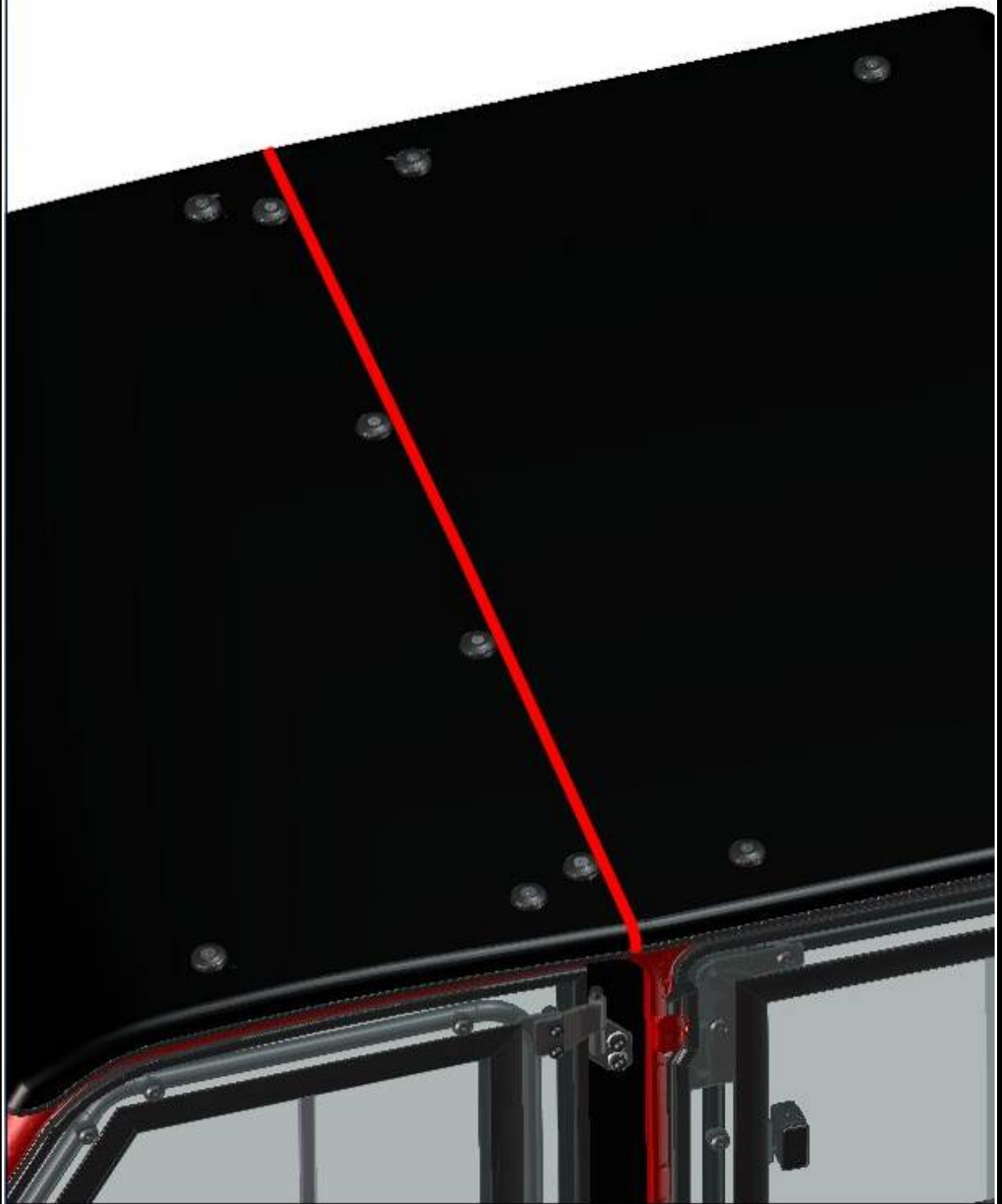

111

FOR ALL TECHNICAL QUESTIONS, PLEASE CALL  
DFK AMERICA INC.  
(630) 324-8585