



INSTALLATION INSTRUCTIONS

HONDA
BIG RED 2012



SAFETY INSTRUCTIONS

Warning: Failure to heed all safety and operating instructions and warnings regarding use of this product can result in serious bodily injury.

PROPERLY READ COMPLETE ASSEMBLY INSTRUCTIONS BEFORE STARTING OF ASSEMBLY

Install all parts indicated in assembly instructions. Failure to fully assemble product before use could result in personal injury.

Assembly of product requires use of hand or power tools. If you are not experienced in using these types of tools, have product dealer do the install for you.

Some parts contain sharp edges, wear protective gloves if necessary.

Always keep your assembly area clean, uncluttered and well lit.

Keep visitors and children a safe distance away from the assembly area. Visitors should wear the same safety equipment described above.

Never operate your UTV with the cab doors open. Failure to properly latch the doors before moving the vehicle could result in serious injury.

Dress for safety. DO NOT wear loose clothing, gloves, neckties or jewelry if using power tools to assemble this product.

Insert all nut covers after you finish installation.

Do not tighten hard any screws or nuts until it will be written.

Never drive your UTV with the cab front window in open position. Failure to properly latch/lock front window before driving the vehicle could result in serious injury.

MAINTENANCE AND CLEANING

To clean polycarbonate surface use soapy water solution or other subtle means.

Dirt and dust wash by gently water stream and swipe only with wet or damp means in the direction from top to bottom.

The recommended frequency of cleaning of polycarbonate part is about 1 time per month or according to the actual degree of pollution.

*Do not use detergents that could scratch the surface plates.
(abrasives, harsh fabrics, etc.)*

*Do not use solvents or alkaline detergents or cleaners with ammonia
(ammonium hydroxide).*

Do not remove the impurities from the surface of the razor blades or other sharp items.

Do not clean cabin when the polycarbonate plates are heated by the sun.

Do not use the squeegee, it could be scratched surface plates.

Do not clean the water current strength greater than 50 bar (WAP)







The manufacturer is not responsible for scratching the surface in case of failure to comply with the above instructions.

All bolted connections of cab must be by user at regular intervals checked and tightened.

TOOLS NEEDED

Not included

		
<p>Ratchet handle</p>	<p>Socket beg 17 mm (0,67 in)</p>	<p>Socket beg 13 mm (0,51 in)</p>
		
<p>Socket beg 10 mm (0,39 in)</p>	<p>Socket beg 8 mm (0,31 in)</p>	<p>Metric wrench 13mm</p>
		
<p>Metric wrench 10mm</p>	<p>Screwdriver philips</p>	<p>Screwdriver straight</p>

		
<p>Hex key 5mm, 6mm and 8mm</p>	<p>Utility knife</p>	<p>Drill ϕ 8-8,5 mm (0,315-0,334 in)</p>
		
<p>Drill ϕ 9-10 mm (0,35-0,39 in)</p>	<p>Drill ϕ 11mm (0,43 in)</p>	<p>Drill ϕ 20-23mm (0,79-0,91in)</p>
		
<p>Socket beg 5 mm (0,2 in)</p>		

PREPARATION FOR INSTALLATION:

Uninstall all additional systems from the UTV's roller cage (work lights, rear mirrors, drink holders etc.)
Uninstall the side safety networks with the holders and plastic doors with the holders from the UTV's roller cage and body.



6

CAB PREVIEW

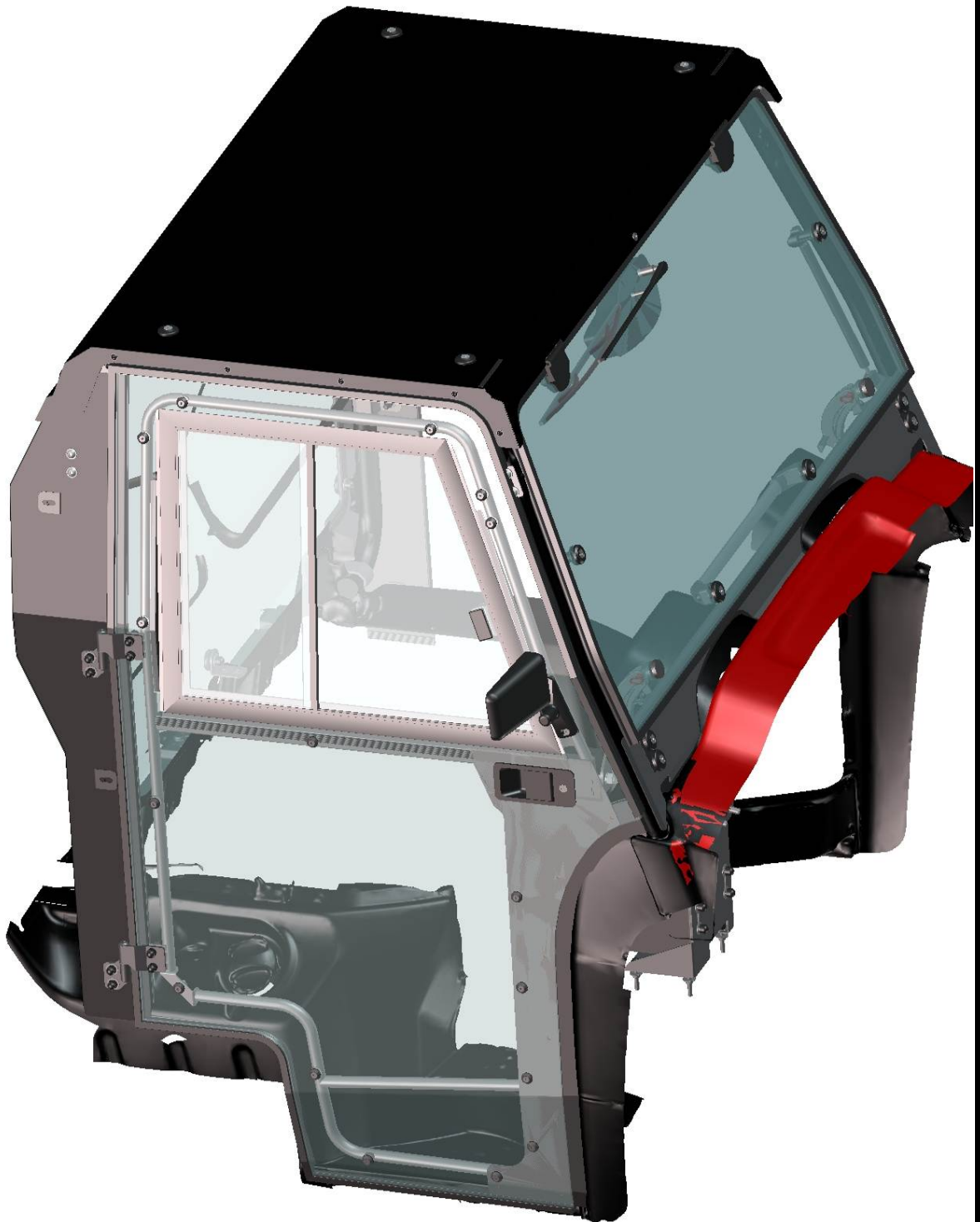

8

REAR PANEL

Uninstall the original screws (in red circles) from UTV's rollercage and place the washer on position.

FOR ALL TECHNICAL QUESTIONS, PLEASE CALL
DFK AMERICA INC.
(630) 324-8585

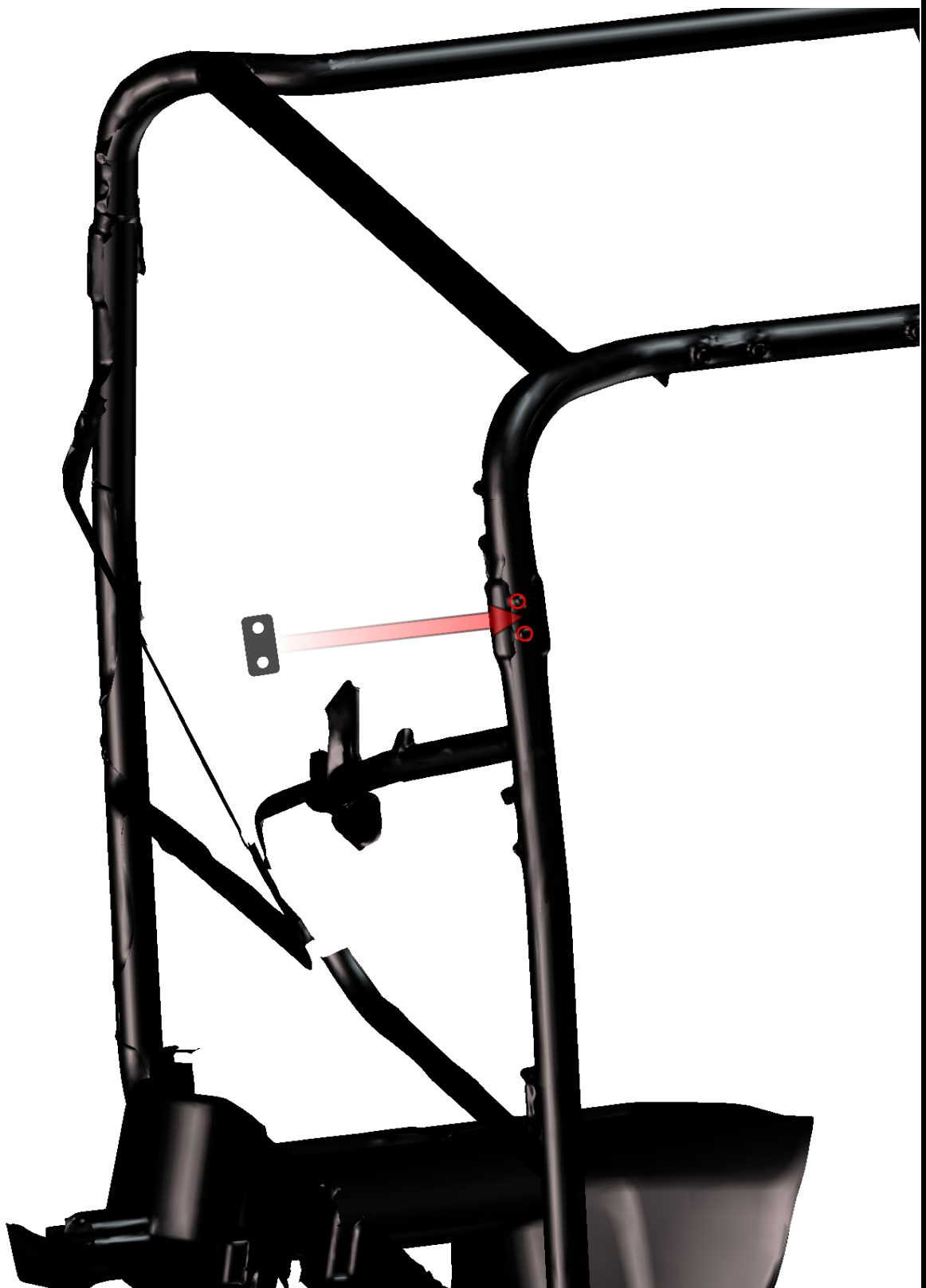

Place the right door base onto the roller cage.

FOR ALL TECHNICAL QUESTIONS, PLEASE CALL
DFK AMERICA INC.
(630) 324-8585



10

Fix the right door base with the washer from page no.:8 and with the roller cage by screws, washers, nuts and nut cover.

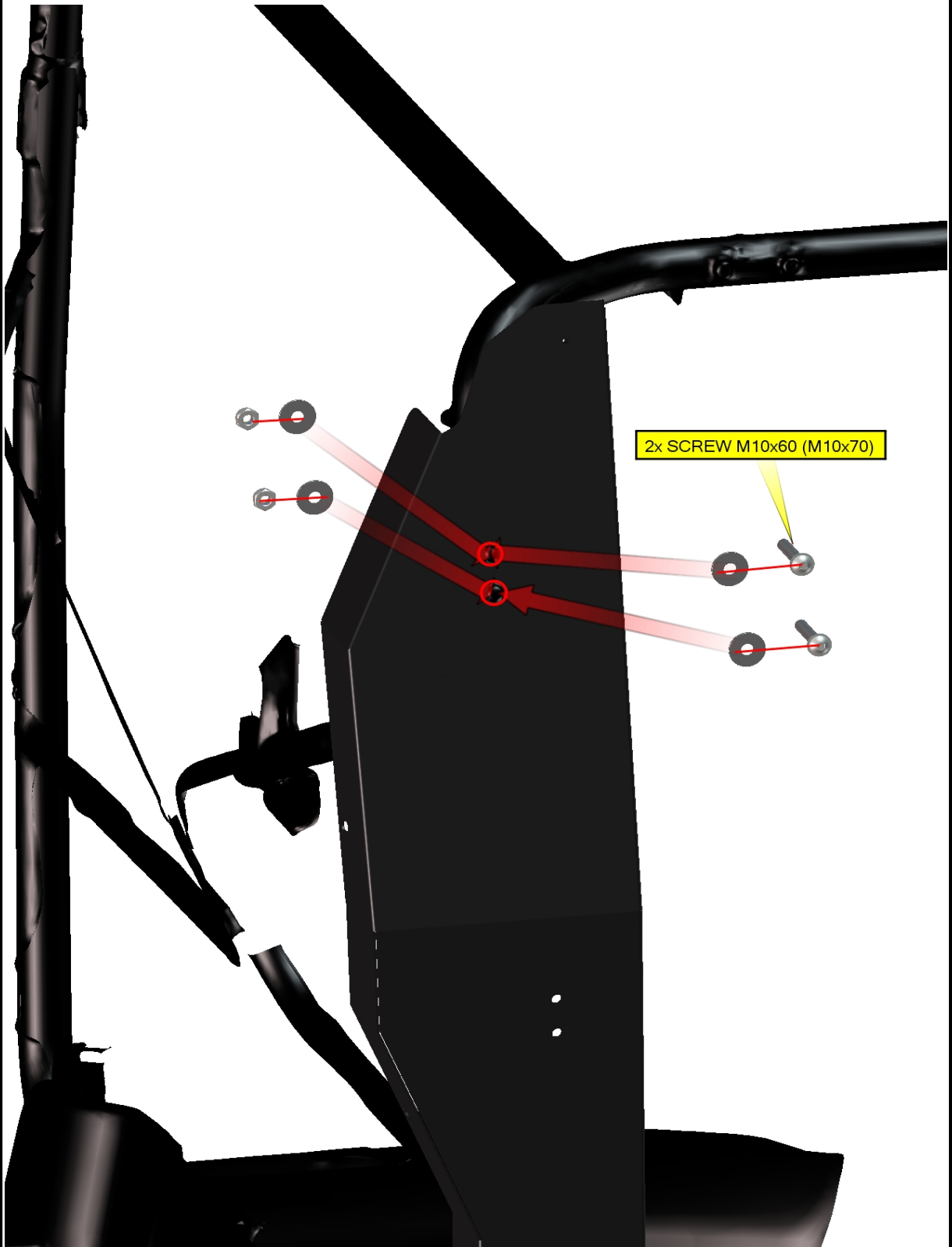

12

Repeat steps from pages No.:8,9 and 10 with left roller cage side and place the holders on the door bases.

FOR ALL TECHNICAL QUESTIONS, PLEASE CALL
DFK AMERICA INC.
(630) 324-8585

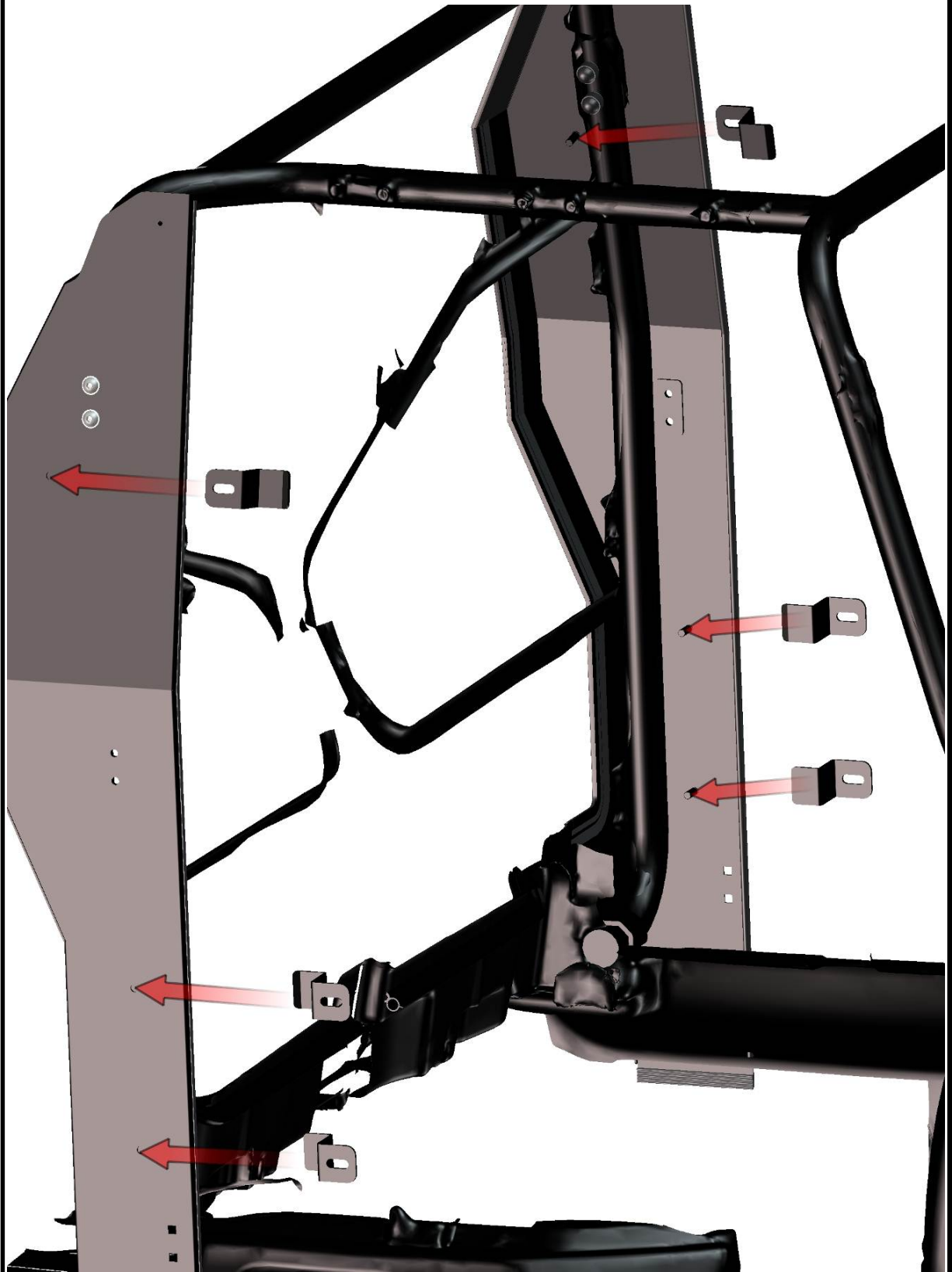

13

FOR ALL TECHNICAL QUESTIONS, PLEASE CALL
DFK AMERICA INC.
(630) 324-8585

Fix the door base holders with the door bases to the roller cage by washers, nuts and nut covers.

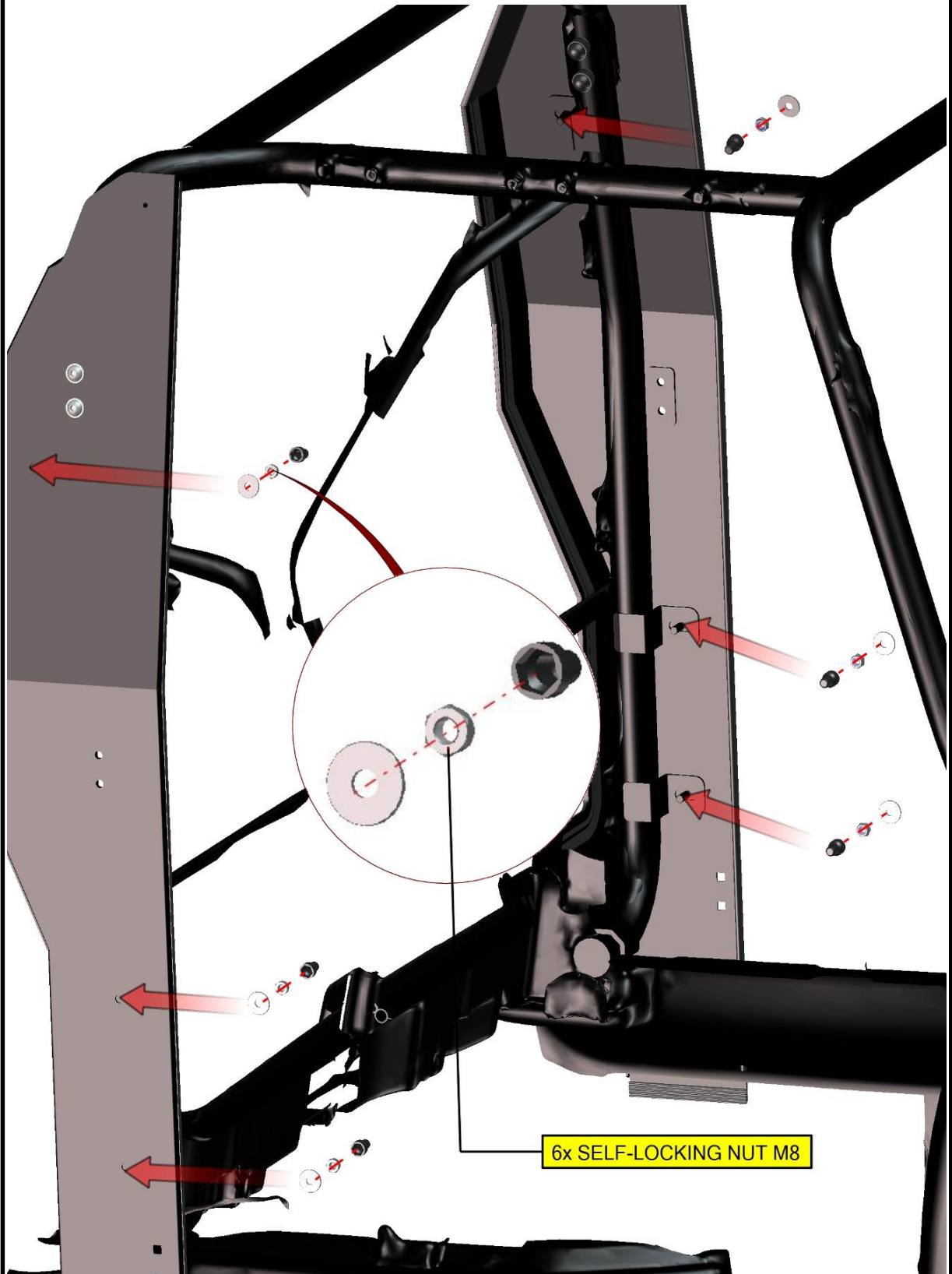

15

FOR ALL TECHNICAL QUESTIONS, PLEASE CALL
DFK AMERICA INC.
(630) 324-8585

Place the door base hook holders (left and right) onto the door bases.

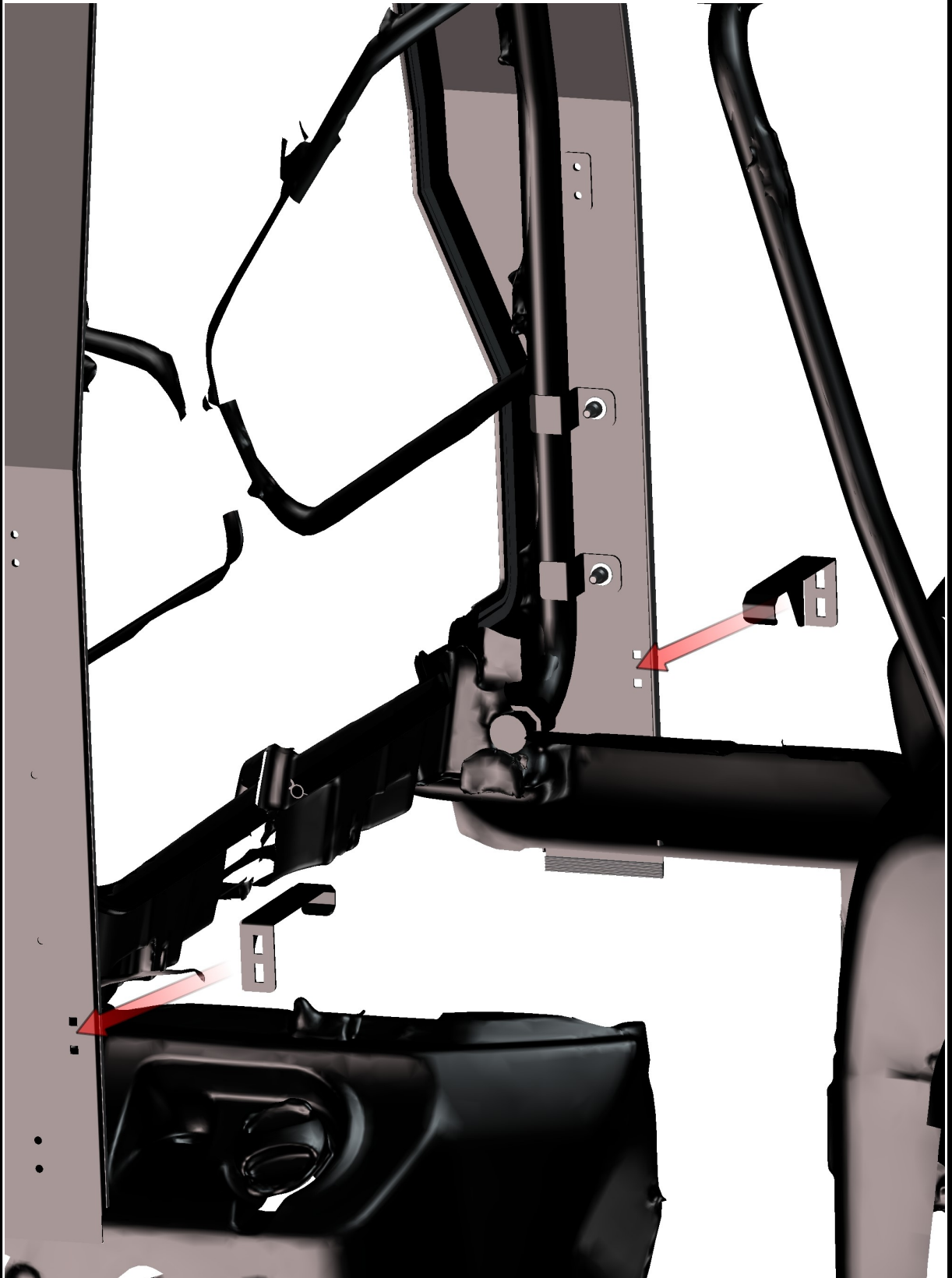

17

FOR ALL TECHNICAL QUESTIONS, PLEASE CALL
DFK AMERICA INC.
(630) 324-8585

Fix the holders with the bases to the roller cage by screws, washers, nuts and covers.

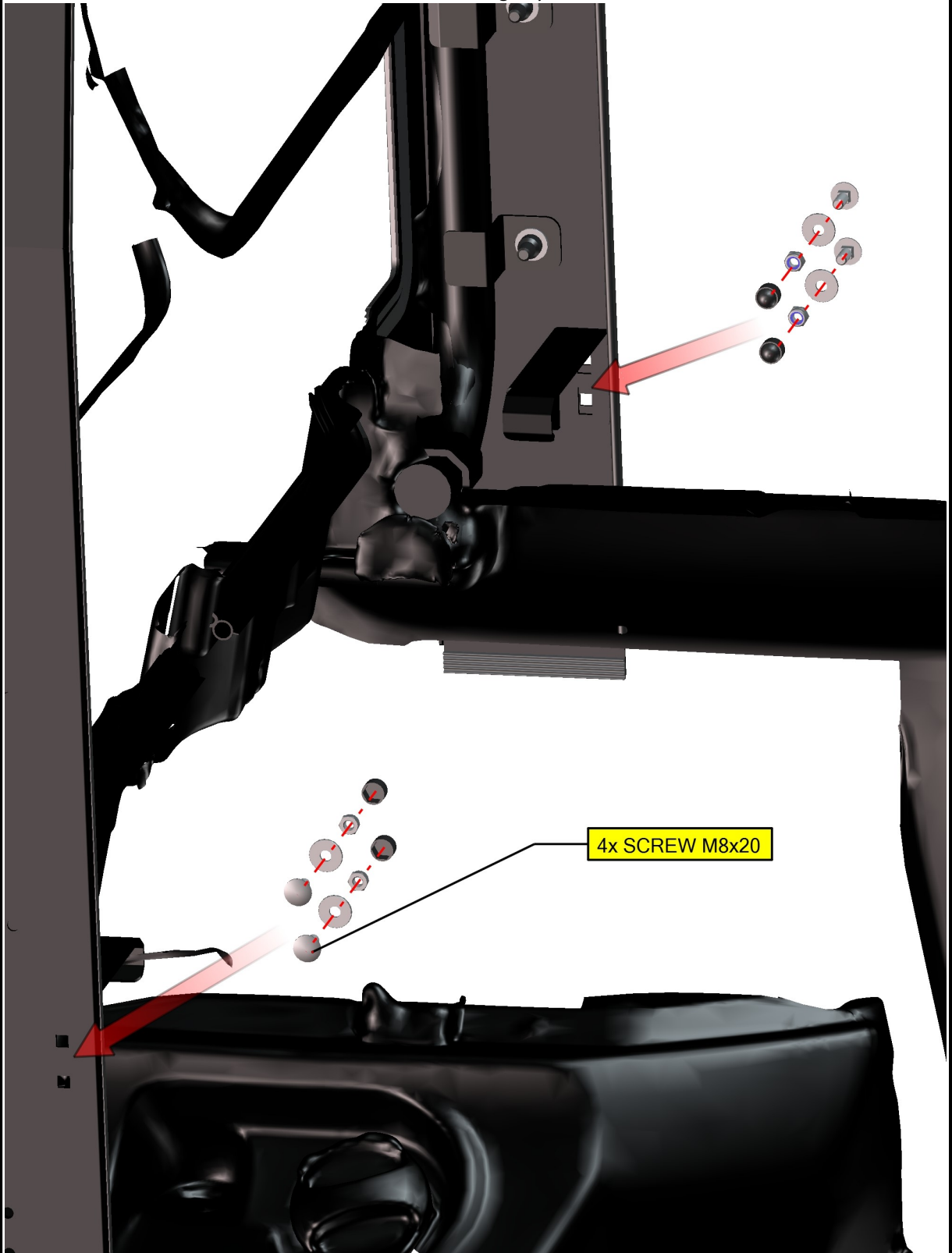

Adjust the door bases on best position and tighten screws and nuts .
Place the rear window bottom holder onto the rear window and fix these by screw, washers, nut and nut cover.

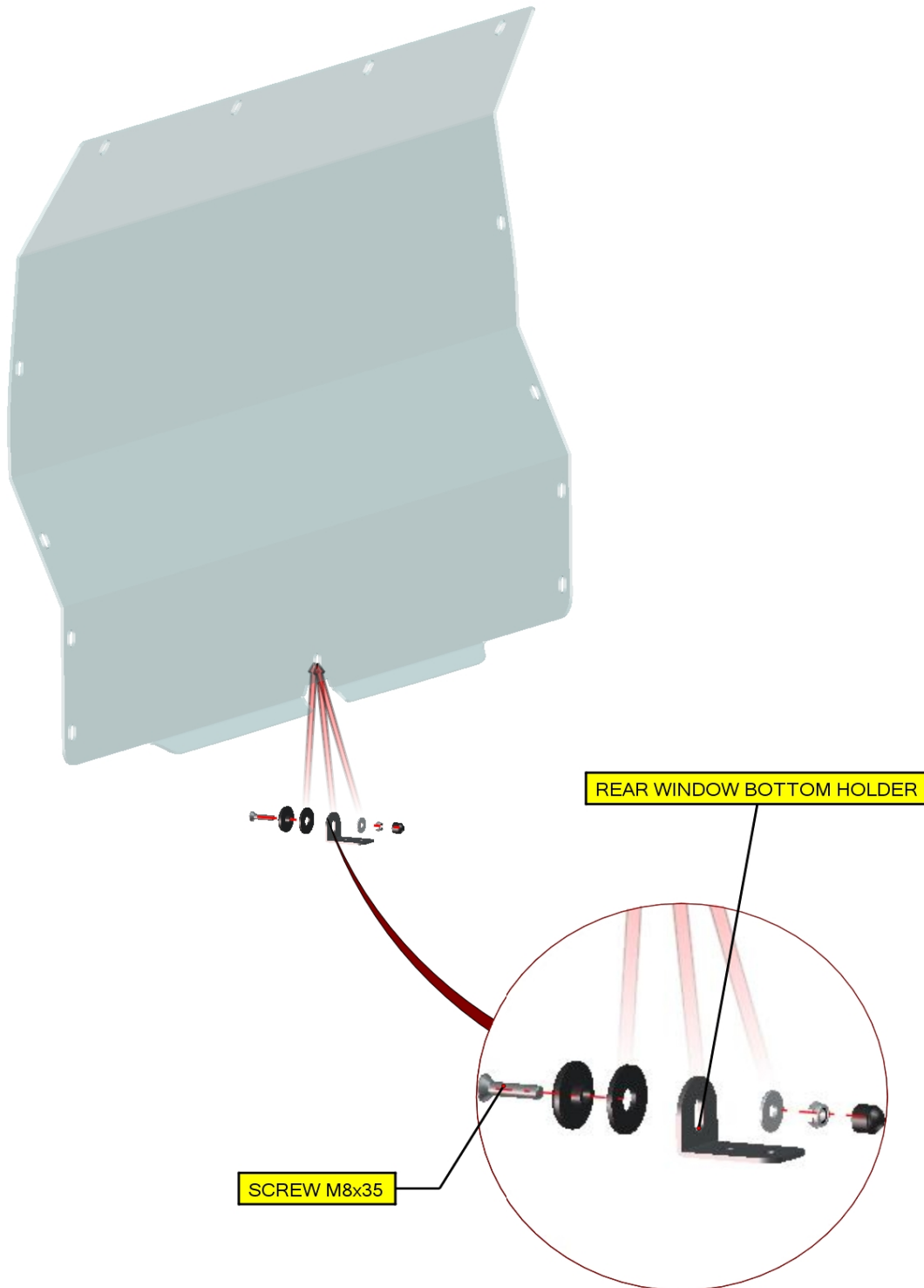

Place the rear window onto the door bases and adjust to good position.

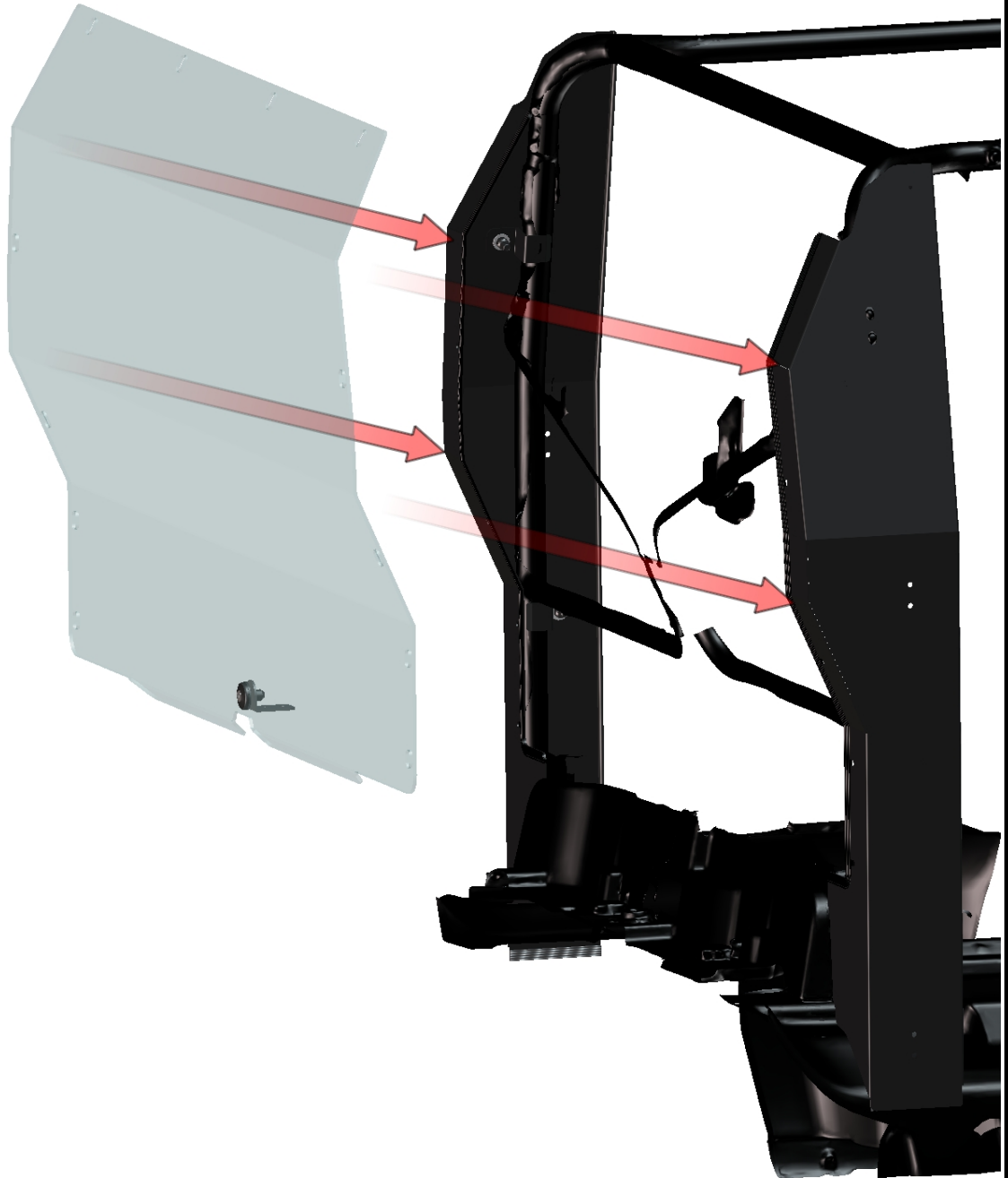

HONDA BIG RED 2012

Fix the rear window with the door bases by screws, washers, nuts and nut covers and make mark (red line) in accordance with rear window bottom outline to the UTV's plastic body .

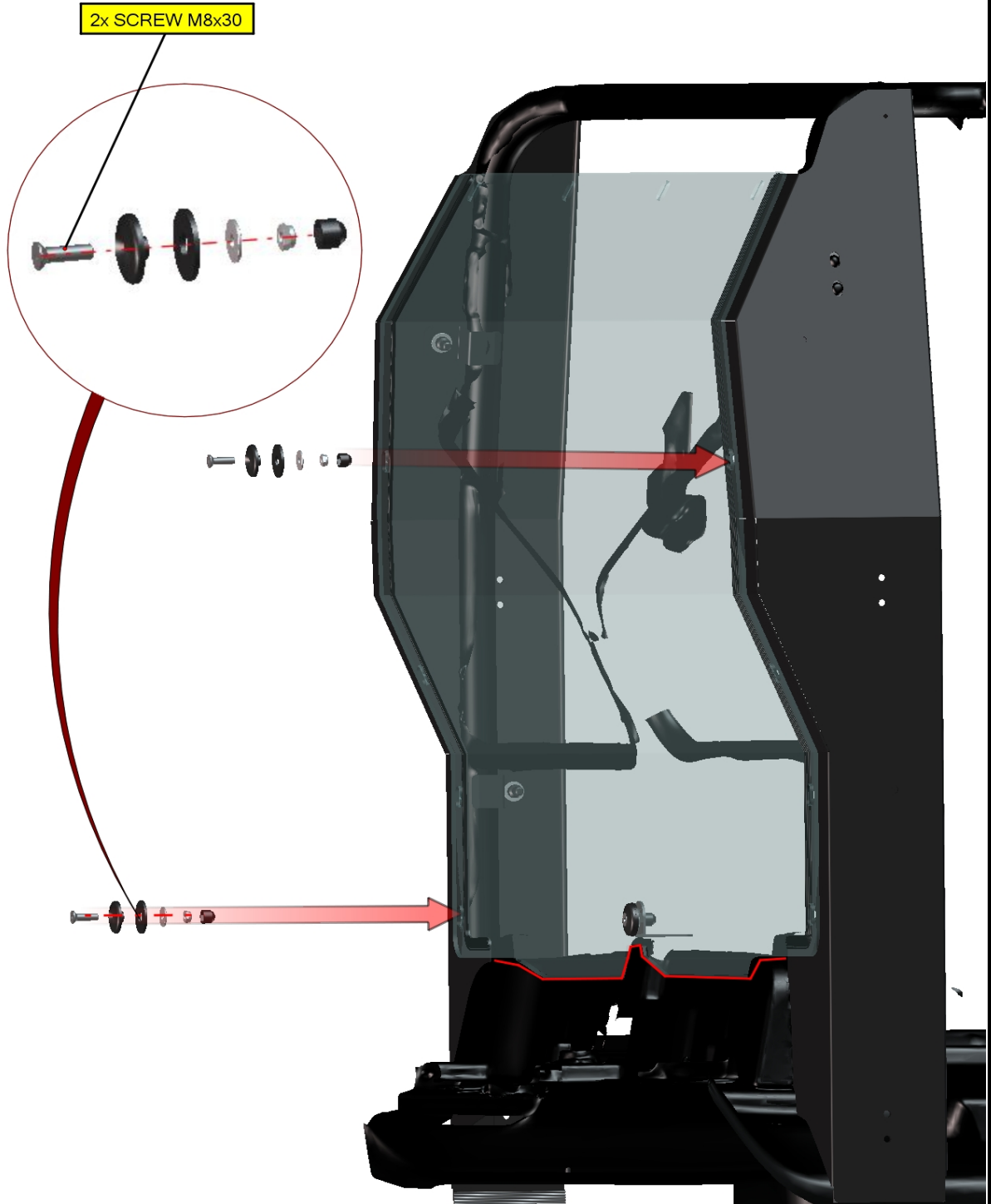

Make marks (red circles) on the UTV's plastic rear bottom body in accordance with the holder's holes.

FOR ALL TECHNICAL QUESTIONS, PLEASE CALL
DFK AMERICA INC.
(630) 324-8585

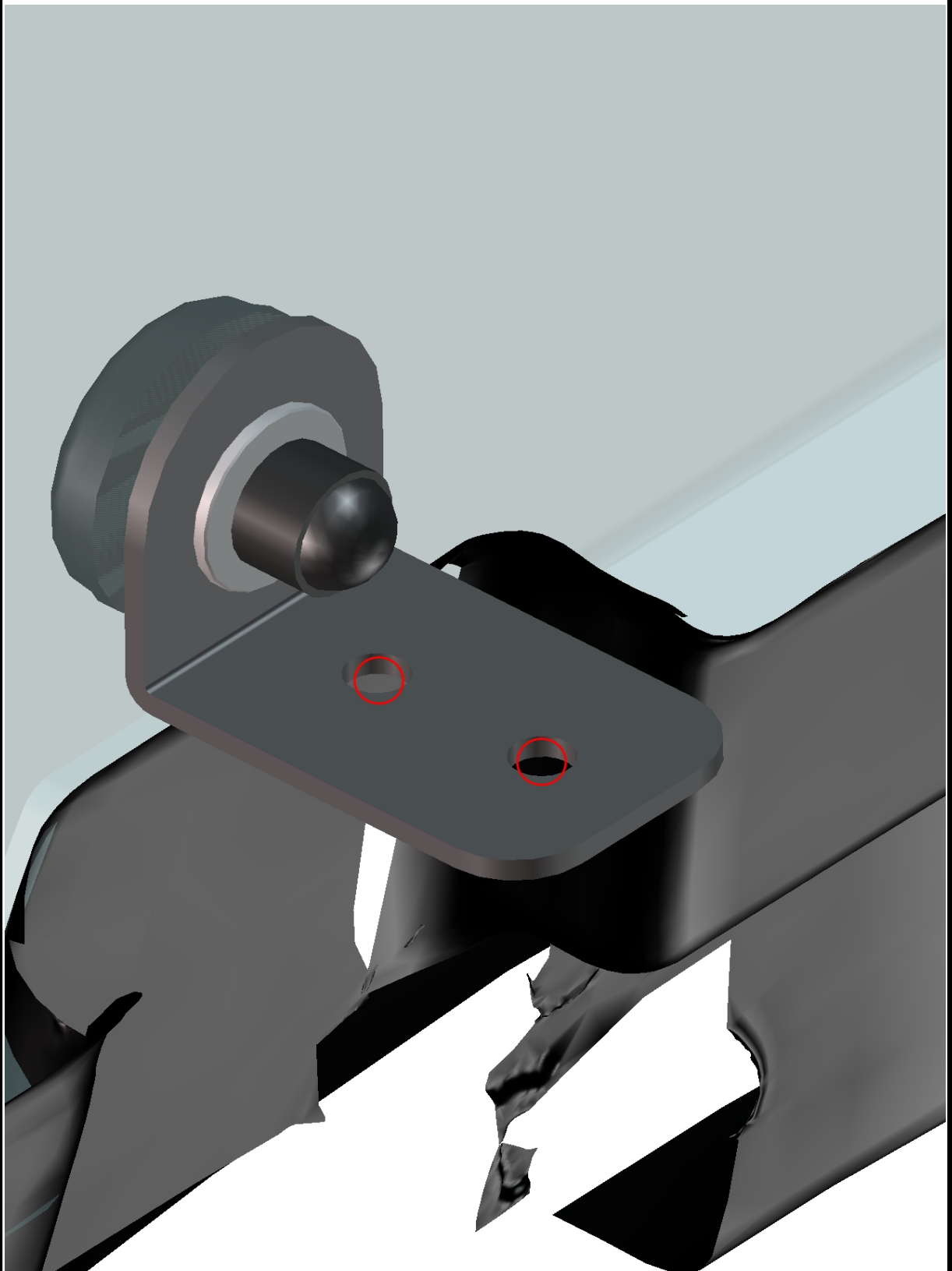

Take out the rear window, drill 2 holes \varnothing 8-8,5mm (**0,315-0,334 in**) in the mark's centers and place the holder back to position. Stick the sealing onto the UTV's body on mark (red line).

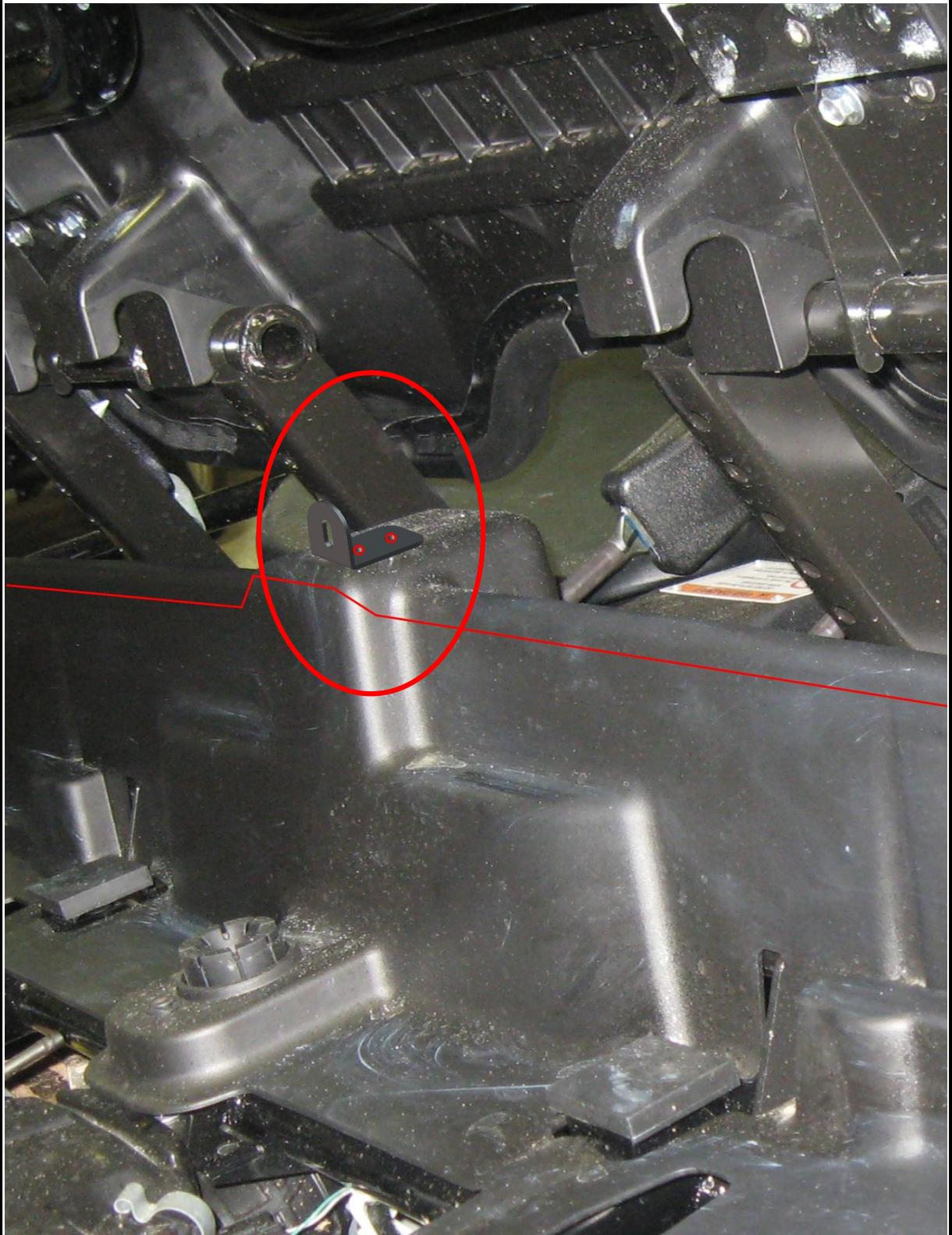

26

Fix the holder with the plastic body by plastic rivet screw 8.

FOR ALL TECHNICAL QUESTIONS, PLEASE CALL
DFK AMERICA INC.
(630) 324-8585



Place the rear window onto the door bases and adjust on the best position.
Fix the rear window with the door bases by screws, washers, nuts and nut covers.

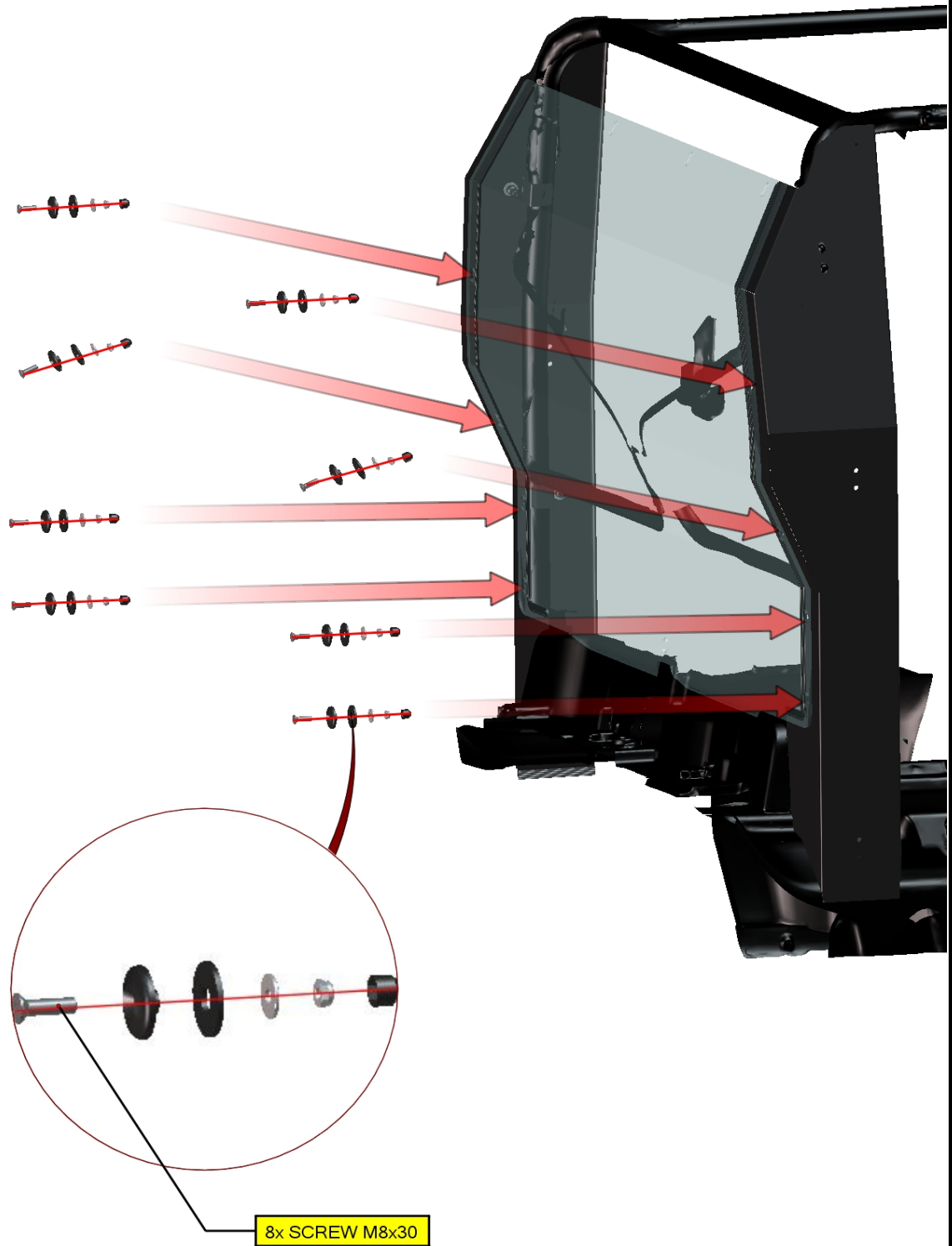

Fix the rear window with the bottom holder by screw from page No.:15

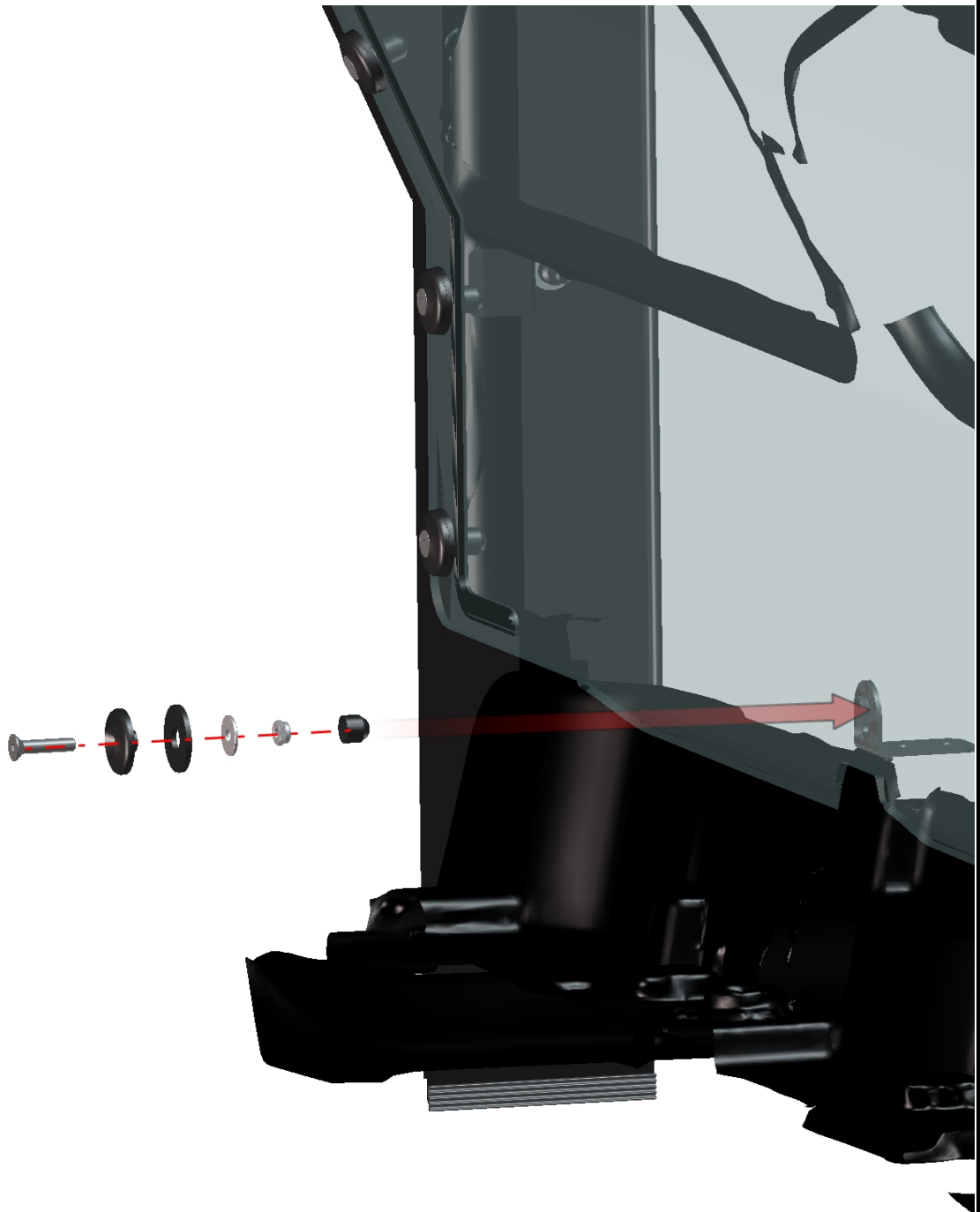

30

Tighten all screws and nuts on the rear panel.

FOR ALL TECHNICAL QUESTIONS, PLEASE CALL
DFK AMERICA INC.
(630) 324-8585

FRONT PANEL

Uninstall the original screws (in red circles) from the front right roller cage and place screws, washers, nuts and nut covers.

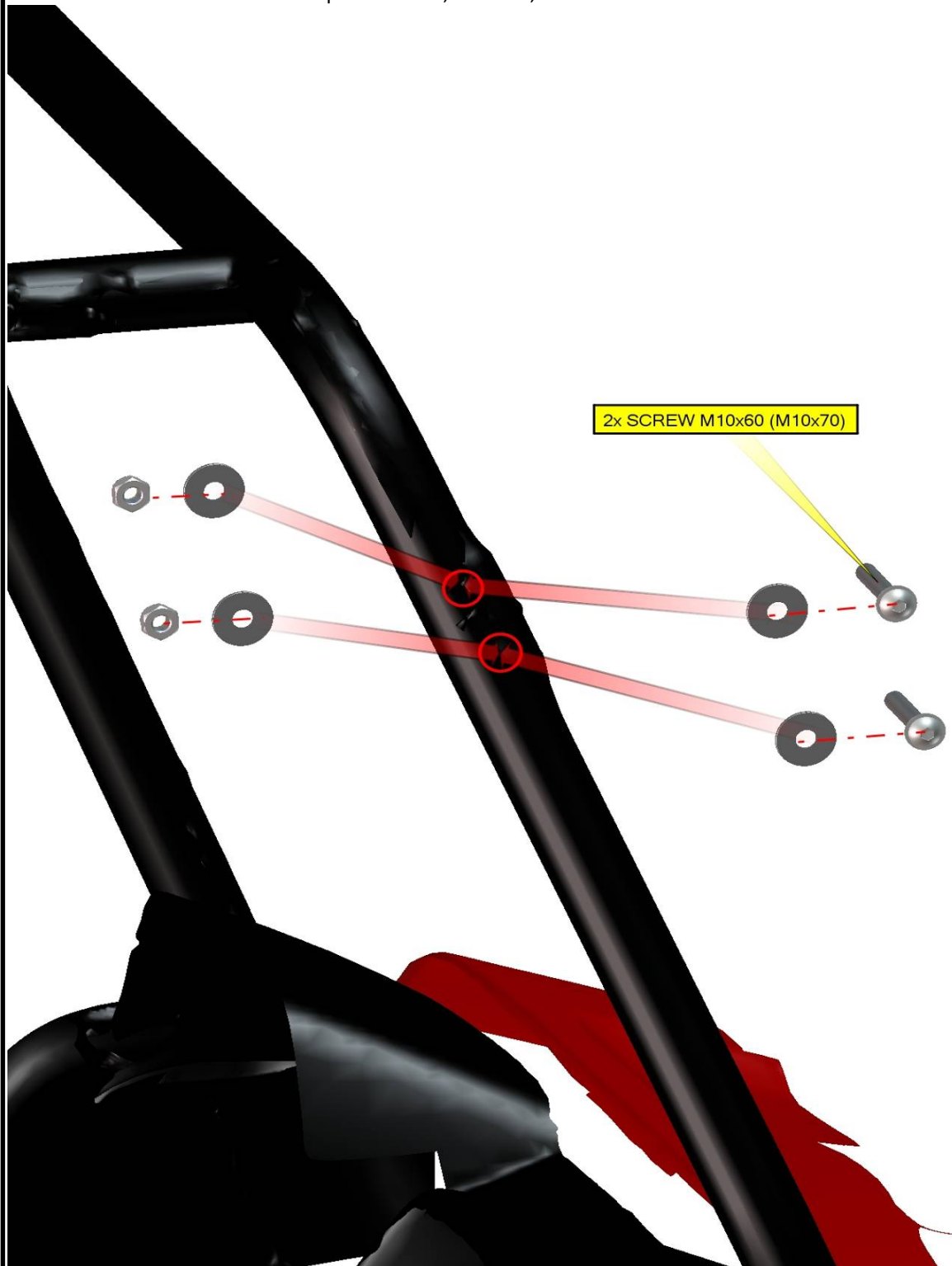

HONDA BIG RED 2012

Repeat this step with the original screws on the left front roller cage.
Install the door stop pin, hook, washer and nut with the door stop holder (step 1.)
Place the door stop onto the front ledge holder (step 2.)
and fix these by nuts, washers and nut covers (step 3.)

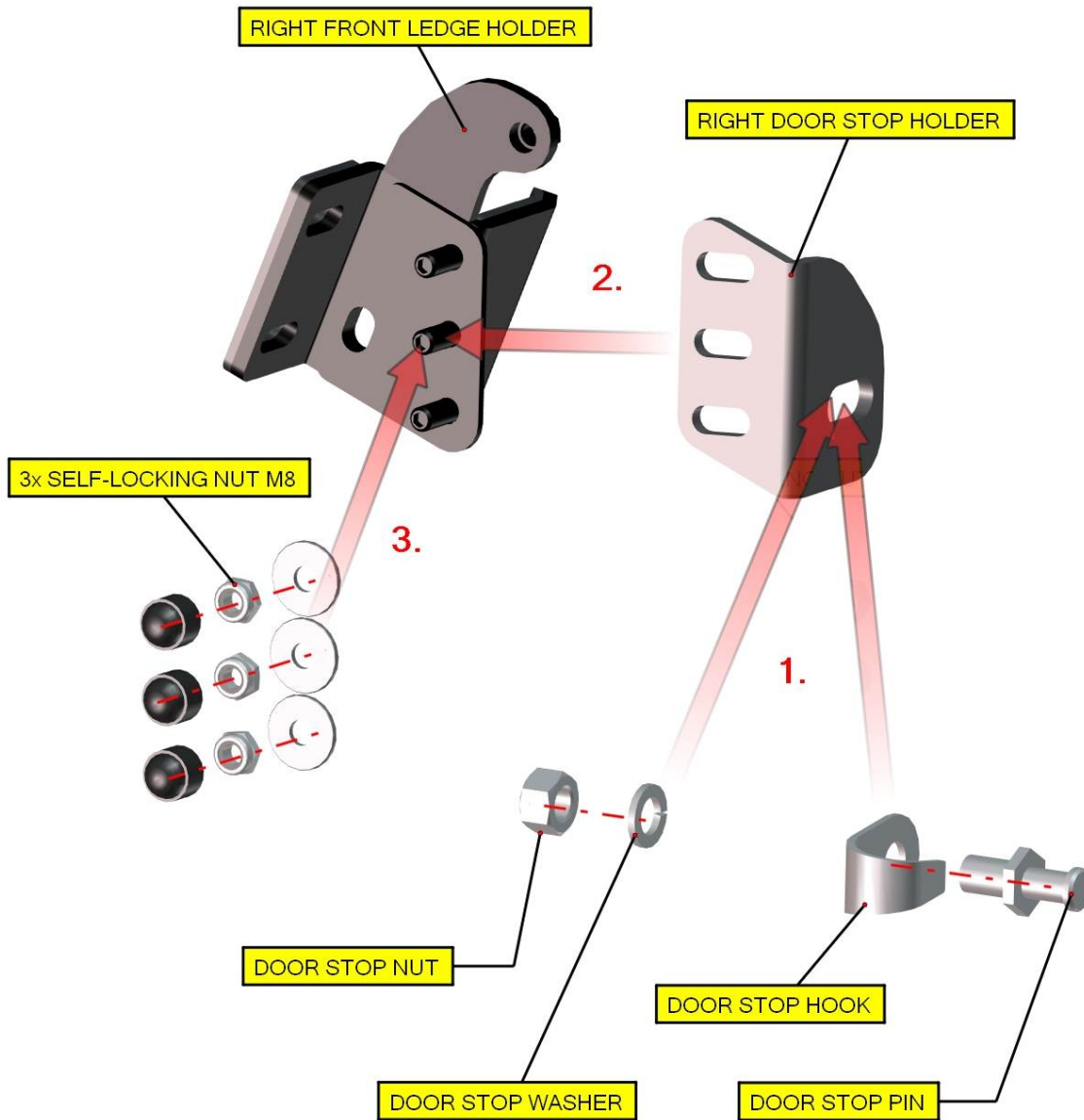

32

HONDA BIG RED 2012

Repeat these three steps with the left holders.
Uninstall upper original screws (in red circles) from the roller cage bottom front corner on both sides.



HONDA BIG RED 2012

Place the front bottom ledge onto the roller cage and press that onto the dashboard.
Stick the EPDM ledge central part under the front cover.



Place the front ledge holders from page No.:24 onto the roller cage on both sides.

FOR ALL TECHNICAL QUESTIONS, PLEASE CALL
DFK AMERICA INC.
(630) 324-8585



FOR ALL TECHNICAL QUESTIONS, PLEASE CALL
DFK AMERICA INC.
(630) 324-8585

Fix the holders with the ledge to the roller cage by screws, washers nuts and nut covers on both sides.

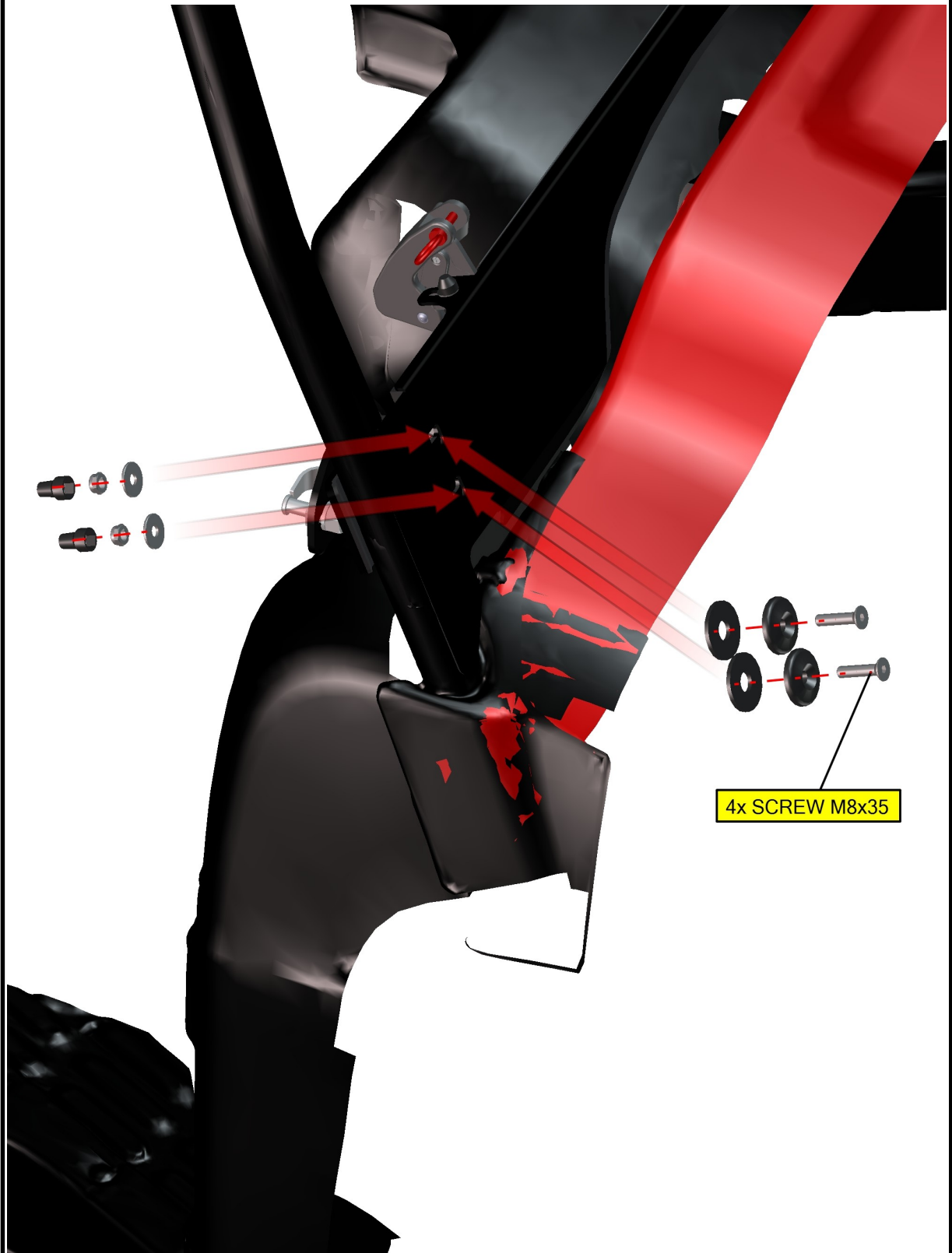

Fix the ledge holders with the roller cage by screws and washers on both sides.

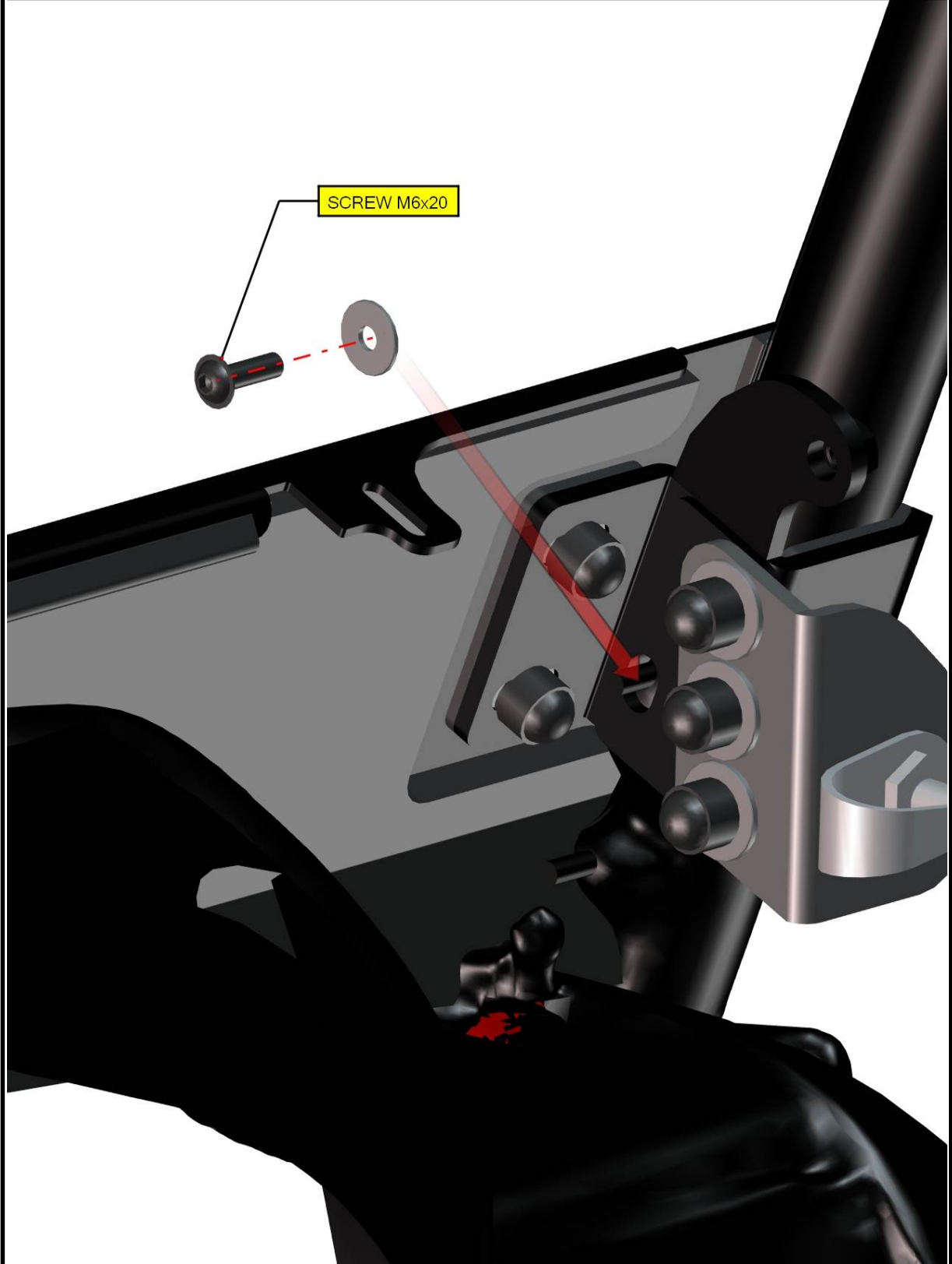

40

Place the front glass assembly and the hinge washers onto the front upper ledge.



Fix the hinges and the hinge washers with the ledge by screws, washers, nuts and nut covers.

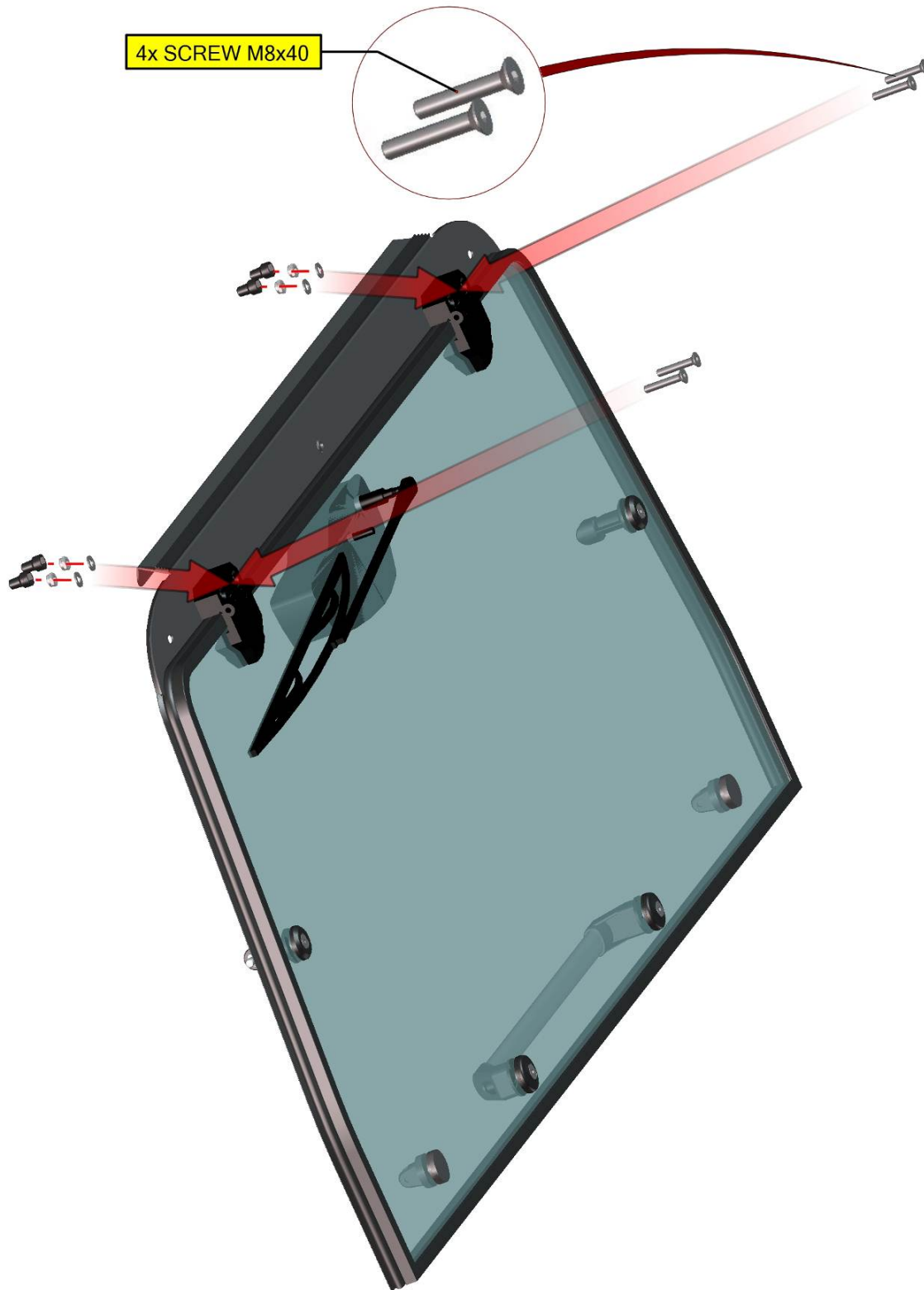

HONDA BIG RED 2012

Place the tightening rings onto the roller cage.



Place the front movable glass with the ledge onto the roller cage.



HONDA BIG RED 2012

Adjust the rings on position and fix the rings with the front ledge by nuts, washers and nut covers on both sides.

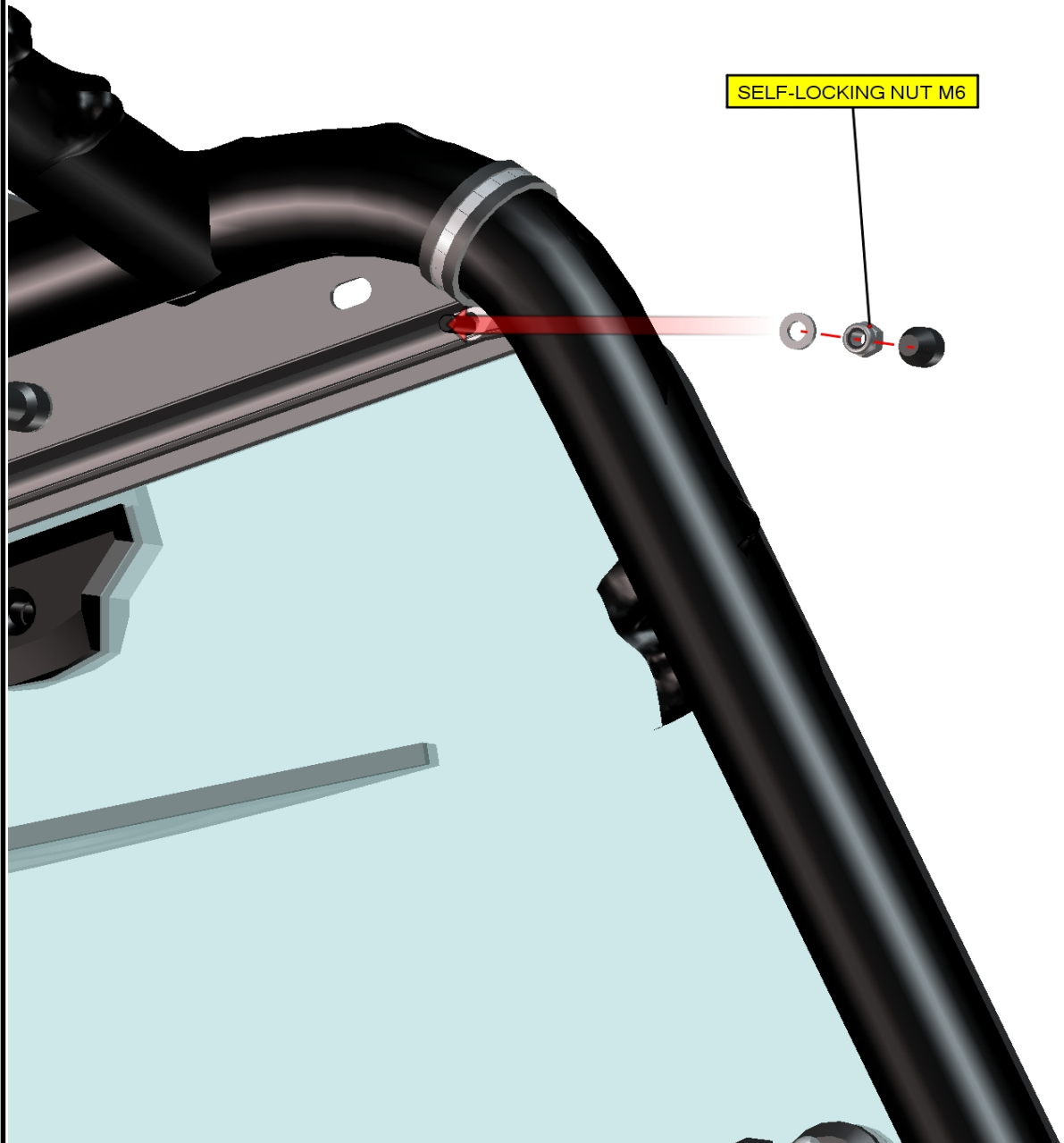

50

Insert the gas spring onto the gas spring holder on both sides.

FOR ALL TECHNICAL QUESTIONS, PLEASE CALL
DFK AMERICA INC.
(630) 324-8585

IT IS IMPORTANT TO INSTALL GAS SPRING IN SAME ORIENTATION LIKE IN PICTURE.

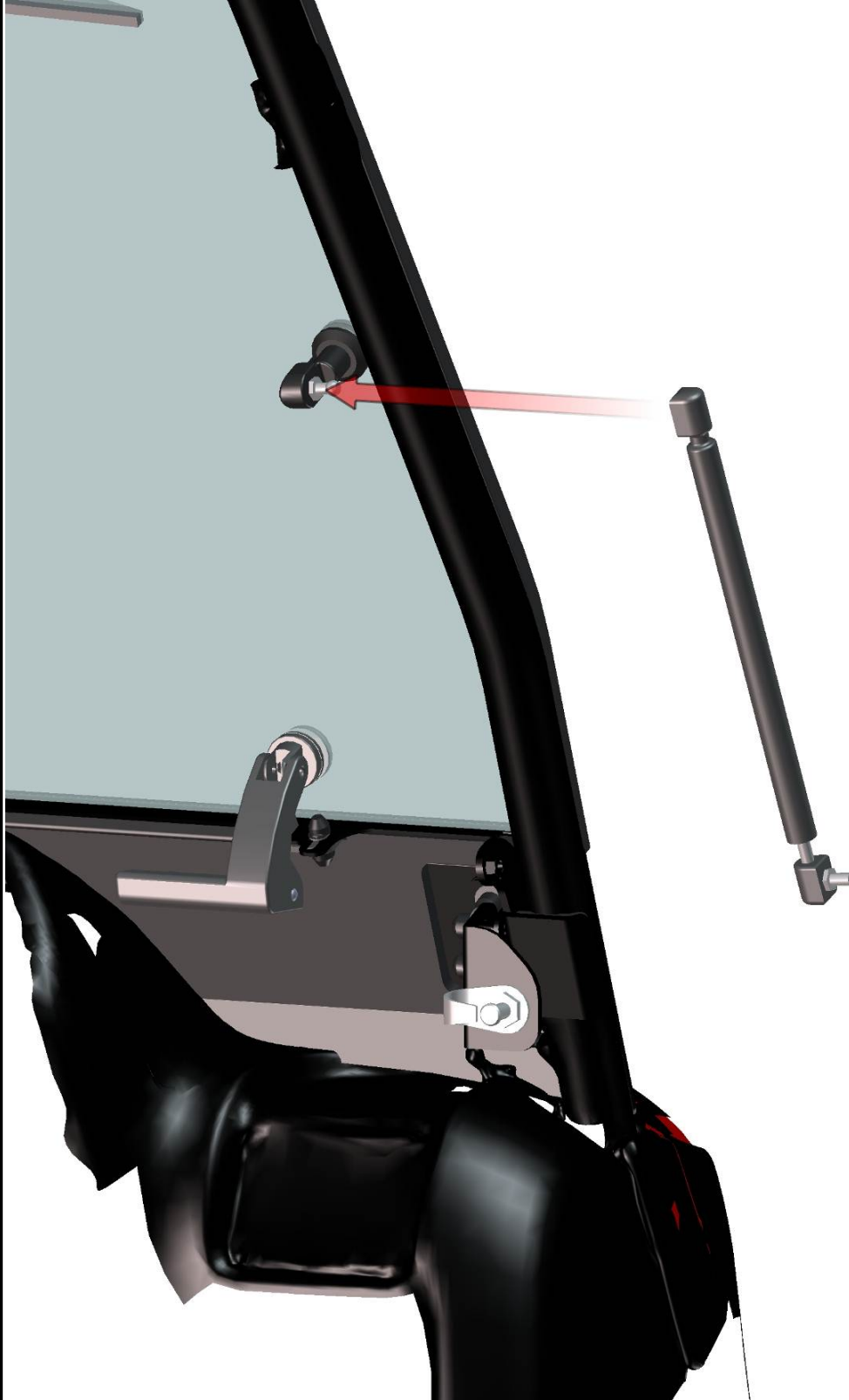

Install the gas spring into the gas spring holder on both sides.

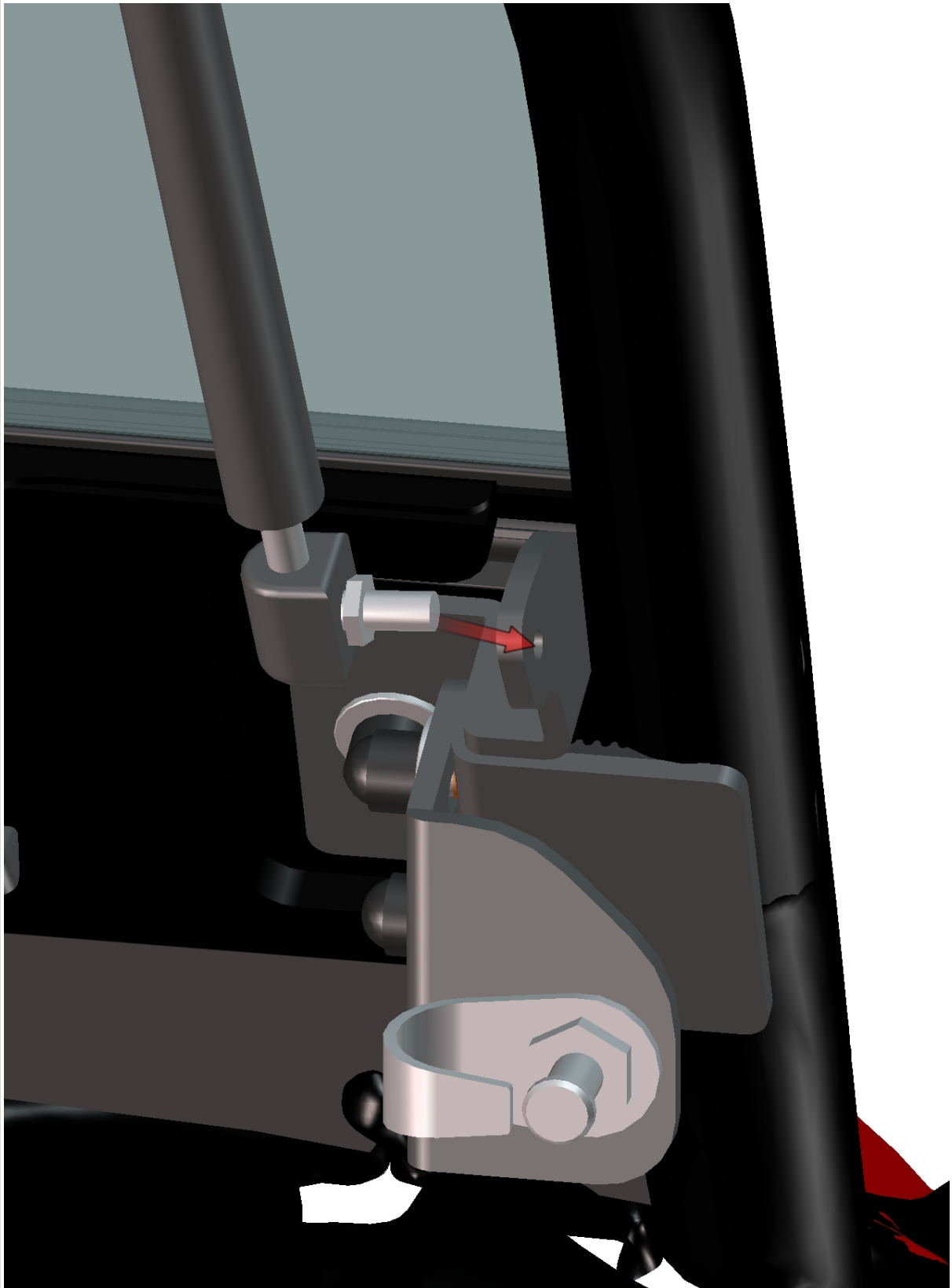

FOR ALL TECHNICAL QUESTIONS, PLEASE CALL
DFK AMERICA INC.
(630) 324-8585

Insert the red pins into the glass locks on both sides.

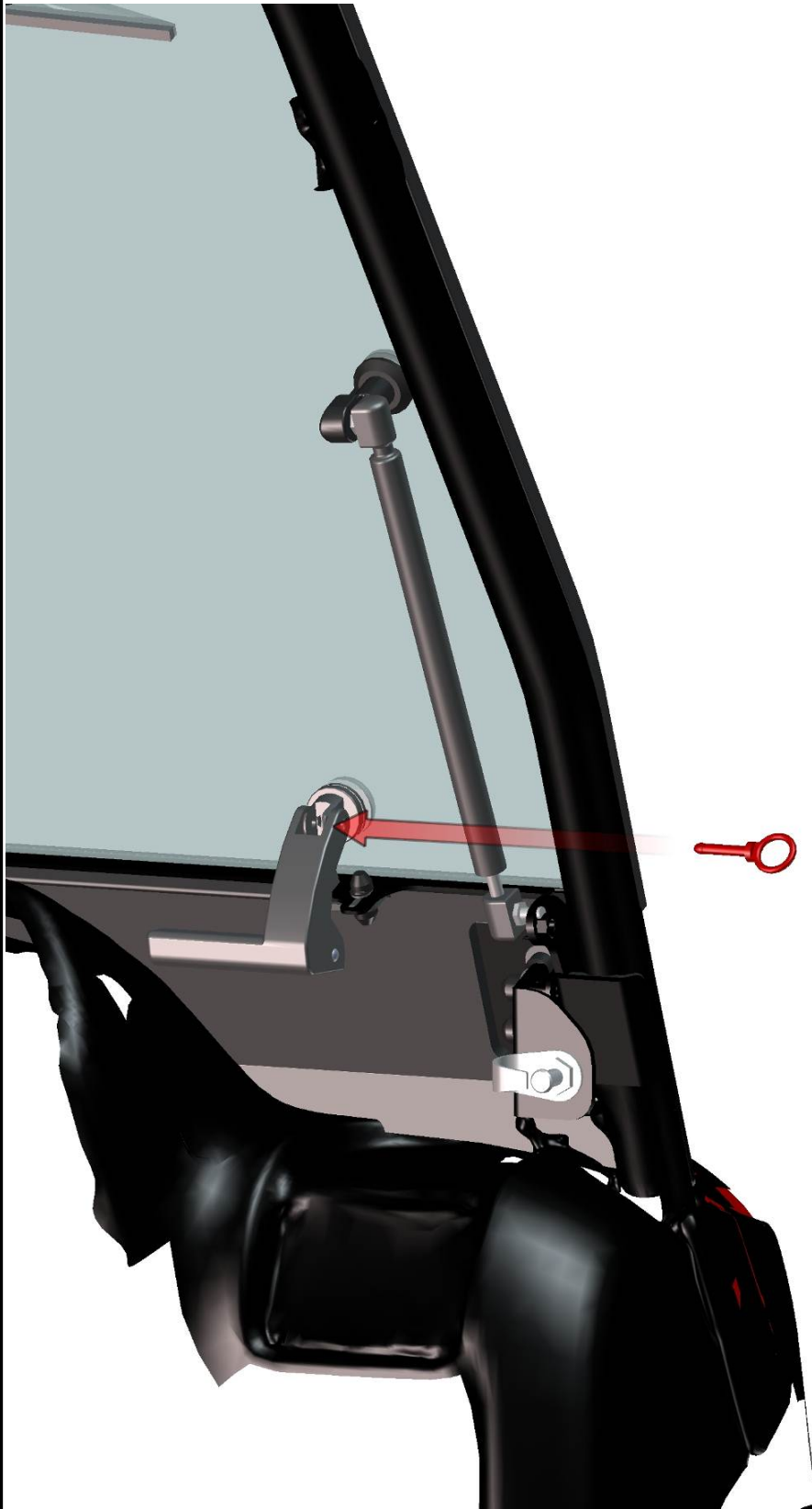

FOR ALL TECHNICAL QUESTIONS, PLEASE CALL
DFK AMERICA INC.
(630) 324-8585

Close the front window slowly and adjust the glass lock holders on both sides to best position. If the front glass sealing doesn't lie on the front bottom ledge or the roller cage correctly, you can repair it by adjusting the glass lock holders to inner side of the cab.



Tighten all screws and nuts on front panel.

FOR ALL TECHNICAL QUESTIONS, PLEASE CALL
DFK AMERICA INC.
(630) 324-8585

If you need, you can open window and stick seal (included) onto the roller cage.



FOR ALL TECHNICAL QUESTIONS, PLEASE CALL
DFK AMERICA INC.
(630) 324-8585

Cut the EPDM front bottom ledge around the front cover holder on both sides.

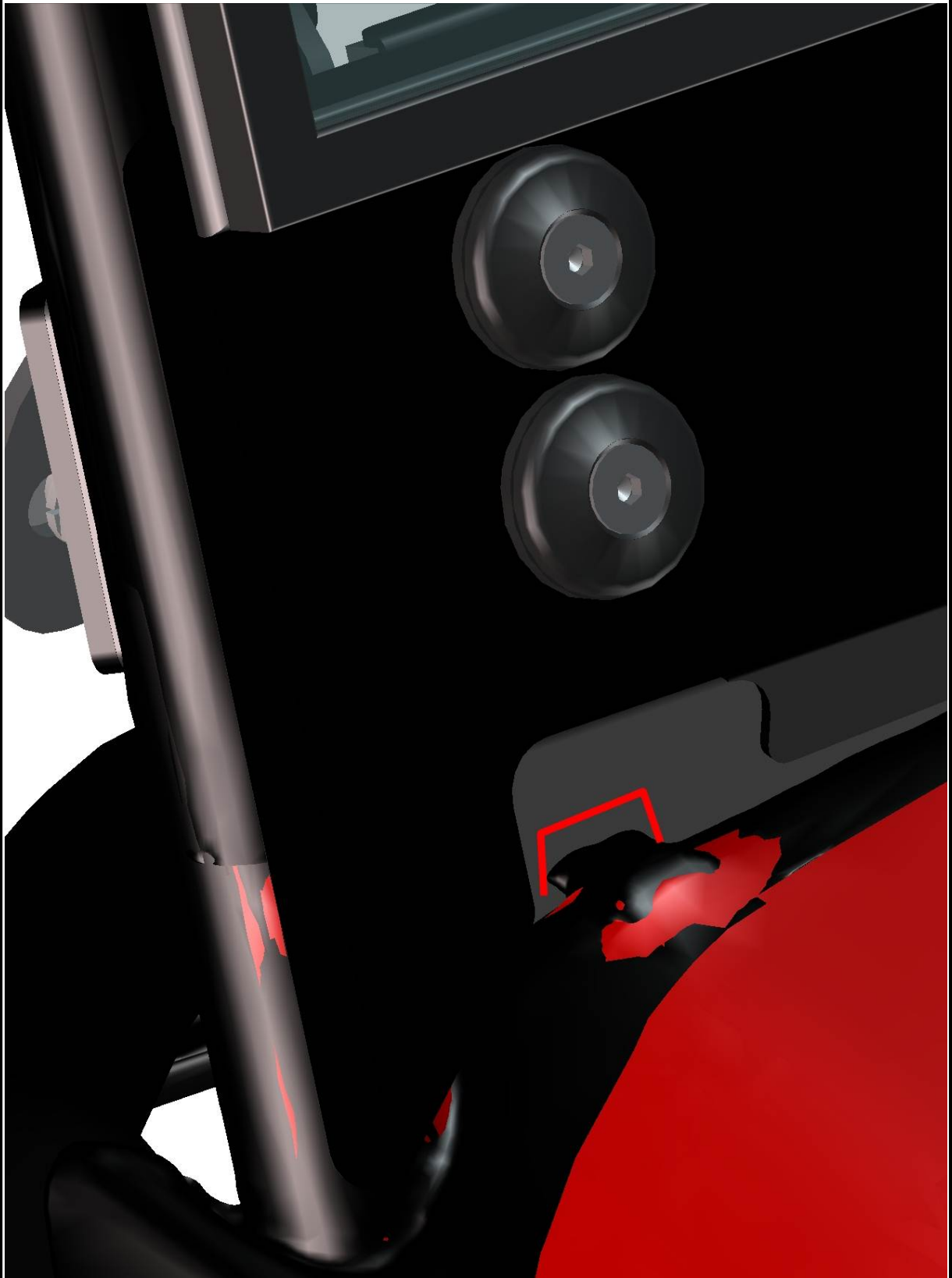

FOR ALL TECHNICAL QUESTIONS, PLEASE CALL
DFK AMERICA INC.
(630) 324-8585

HONDA BIG RED 2012

ROOF PANEL

Place the roof holders onto the roof.

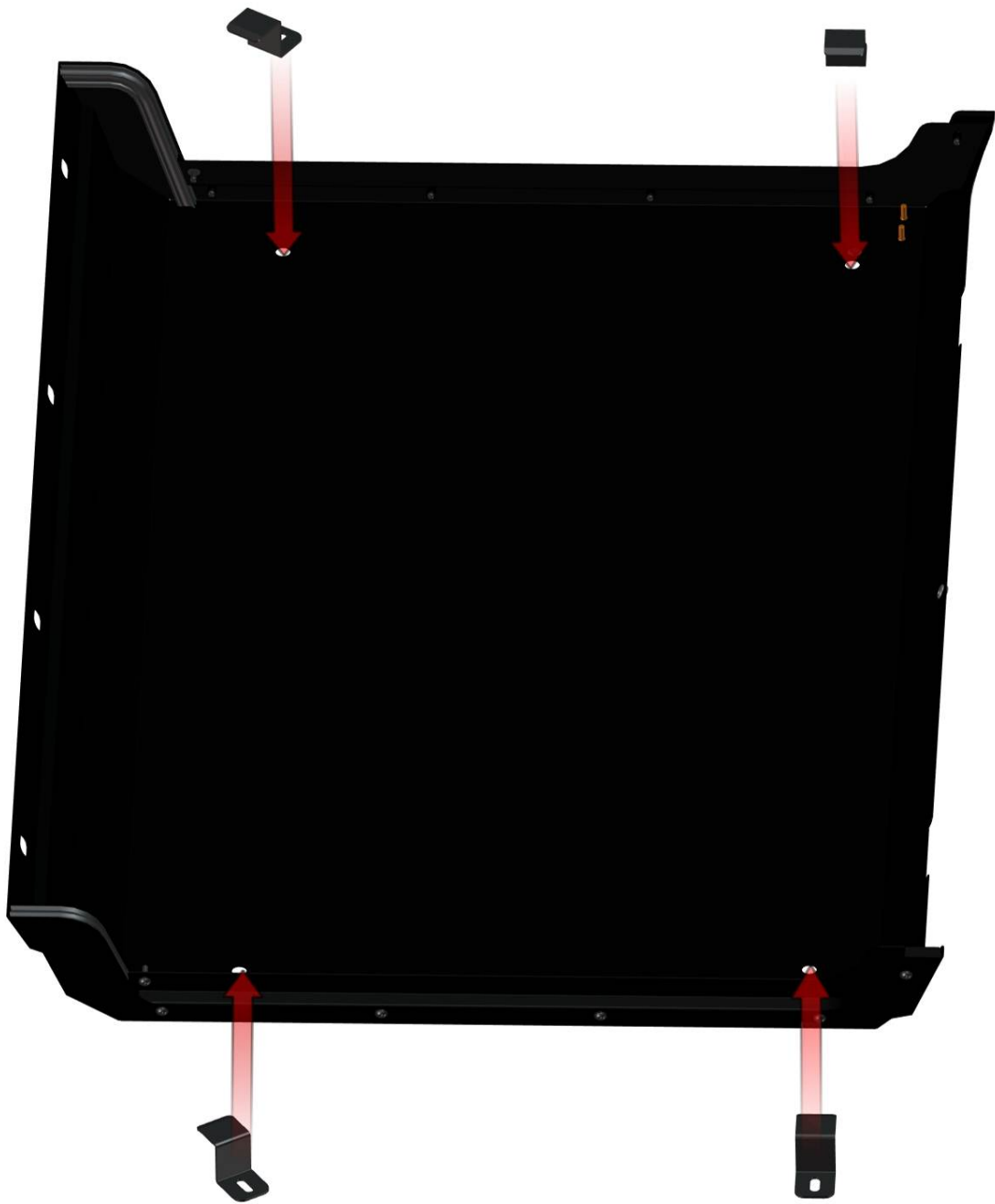

62

Install screws and washers into the roof and into the roof holders.

FOR ALL TECHNICAL QUESTIONS, PLEASE CALL
DFK AMERICA INC.
(630) 324-8585



FOR ALL TECHNICAL QUESTIONS, PLEASE CALL
DFK AMERICA INC.
(630) 324-8585

HONDA BIG RED 2012

Fast-lock assembly (explode view).

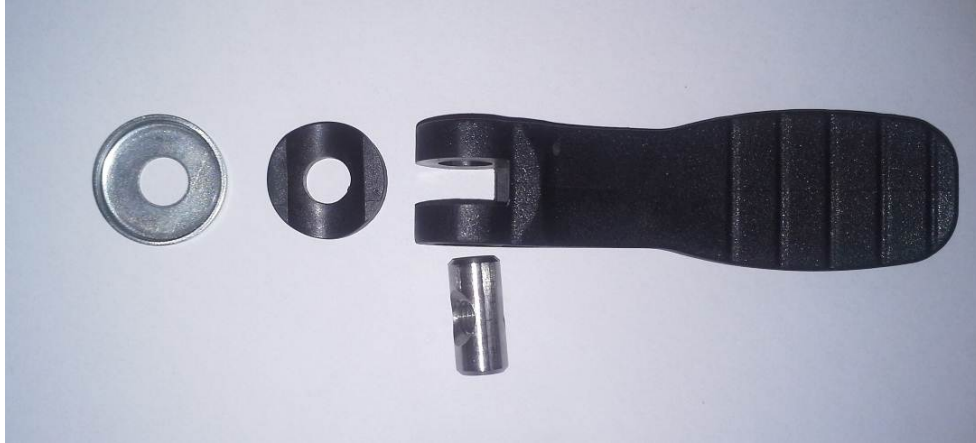

Fast-lock handle mounted.



Fast-lock handle tightened.



Fix the roof with the roof holders by the fast-lock handles and screws.



66

HONDA BIG RED 2012

Place the front upper corners onto the roof front part.

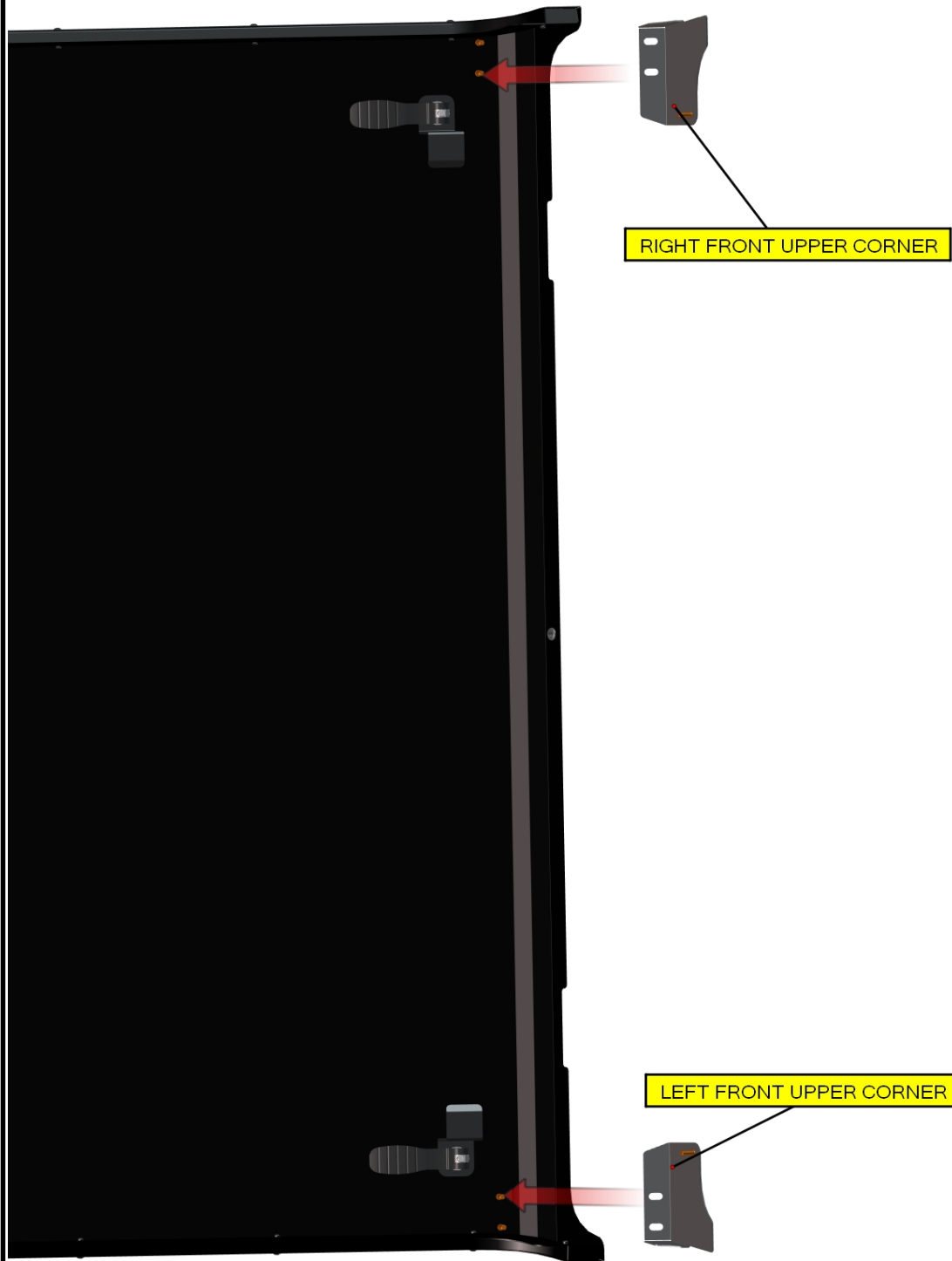

Fix the corners with the roof by nuts, washers and nut covers on both sides and don't tighten now.

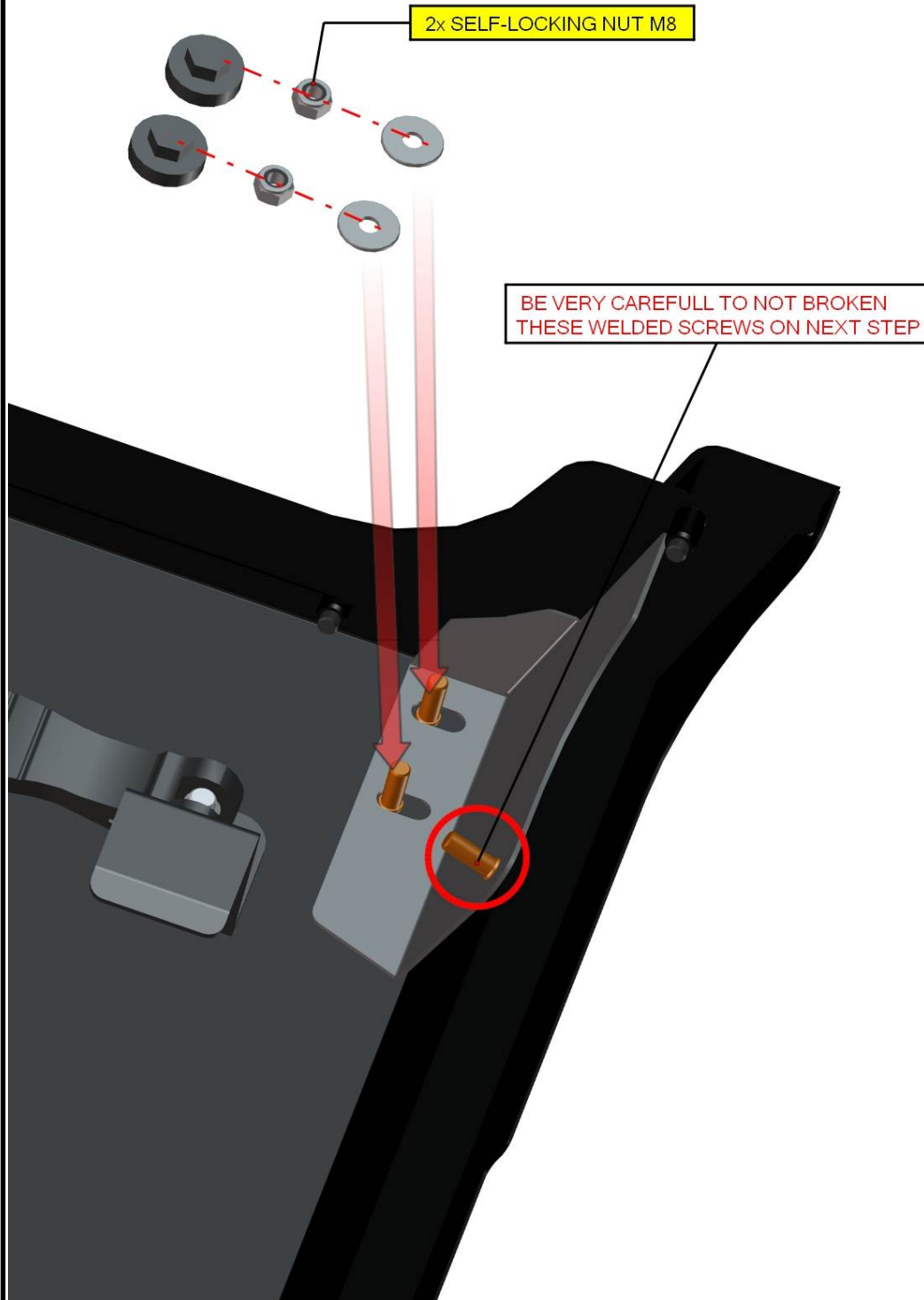

HONDA BIG RED 2012

Place the roof onto the front upper ledge GENTLY, and adjust the front upper corners to best position. Insert the welded screws (on previous page in red circle) into the front upper ledge's holes (on detail view).

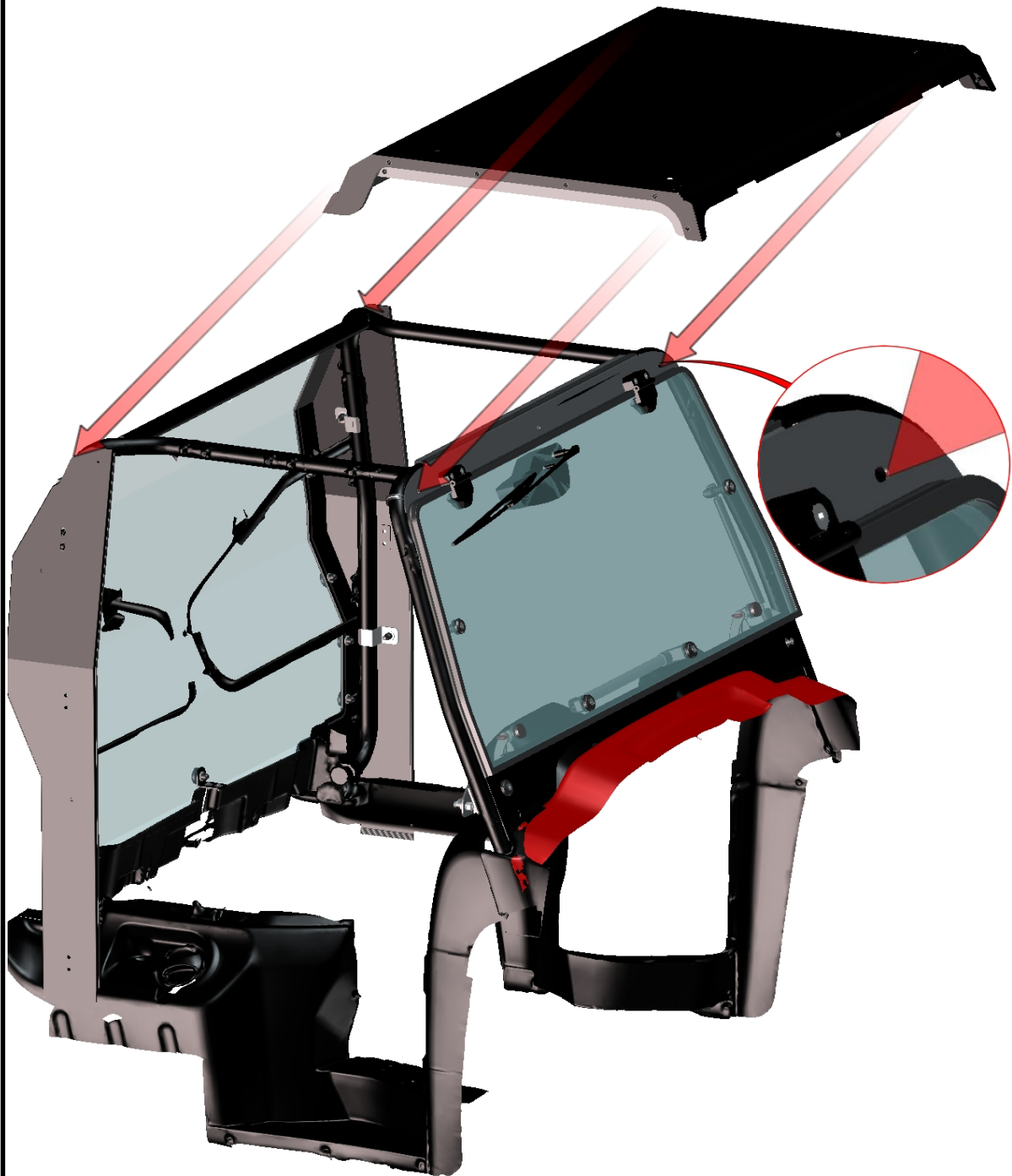

71

Adjust the roof gently to correct position and fix that with the door bases on both sides by screws.

FOR ALL TECHNICAL QUESTIONS, PLEASE CALL
DFK AMERICA INC.
(630) 324-8585

SCREW M6x20

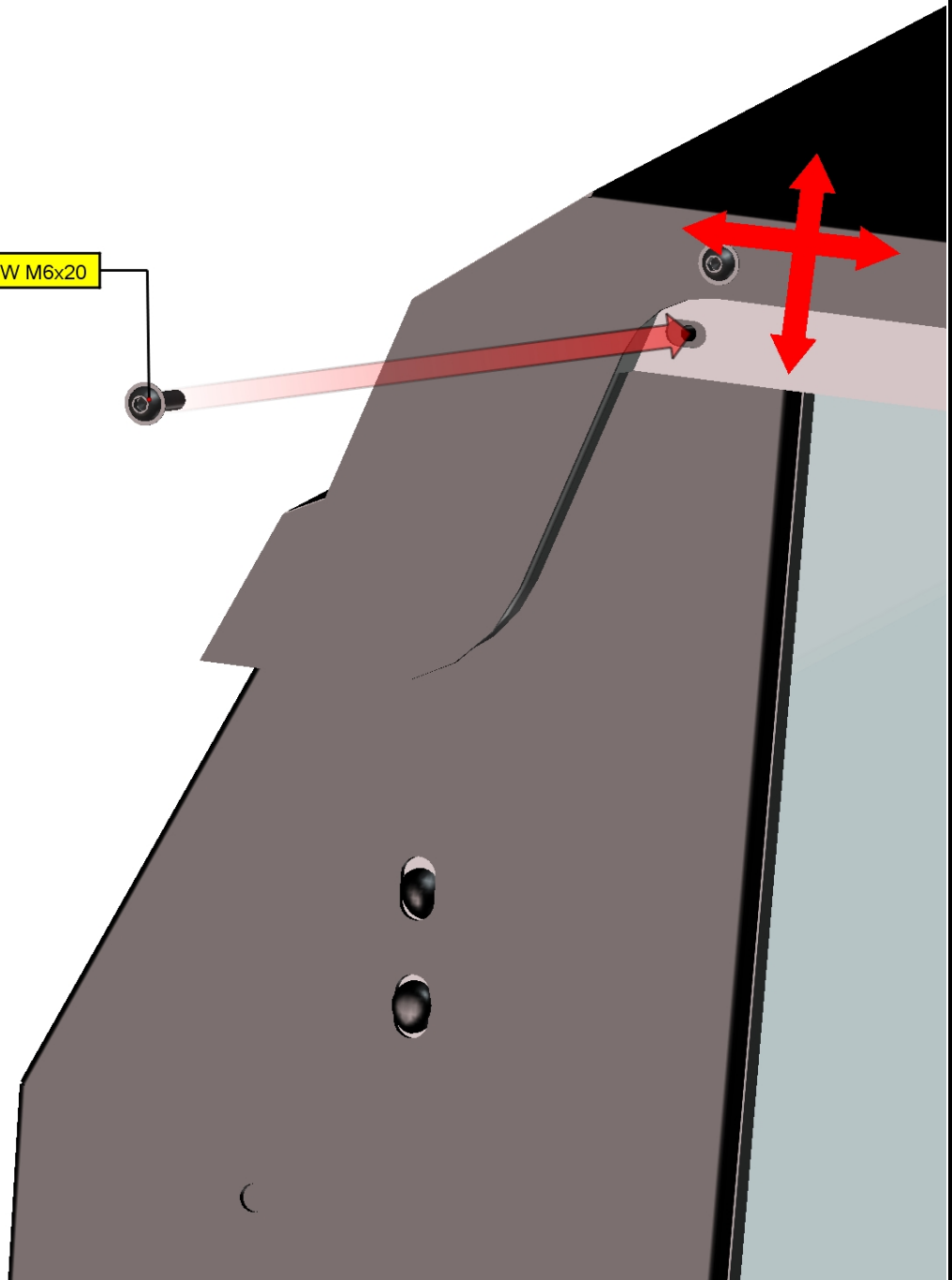

72

Fix the roof with the rear window by screws, washers, nuts and nut covers.

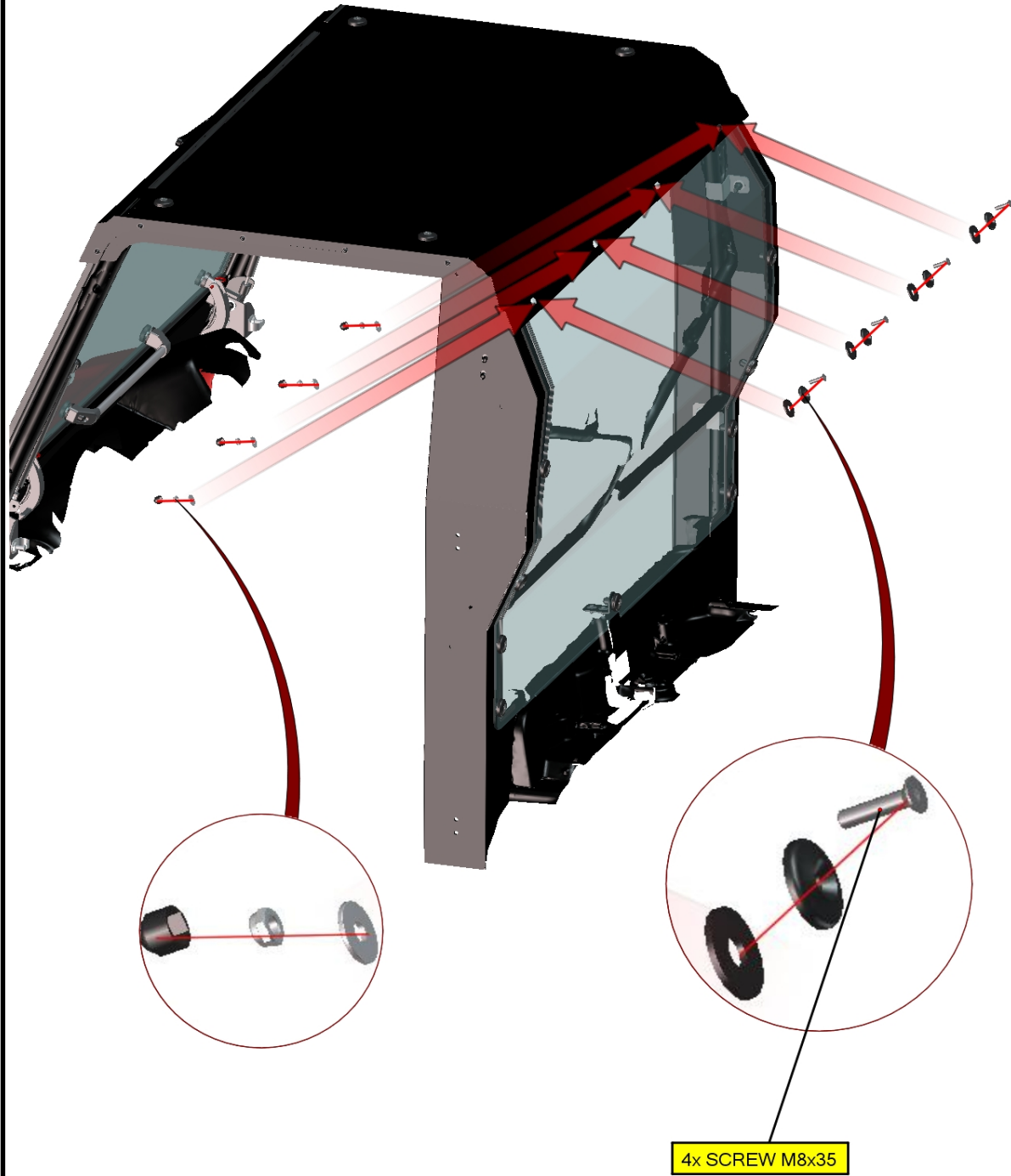

Adjust the corners from page No.: 46 on best position and fix these with nuts, washers and nut covers on both sides.

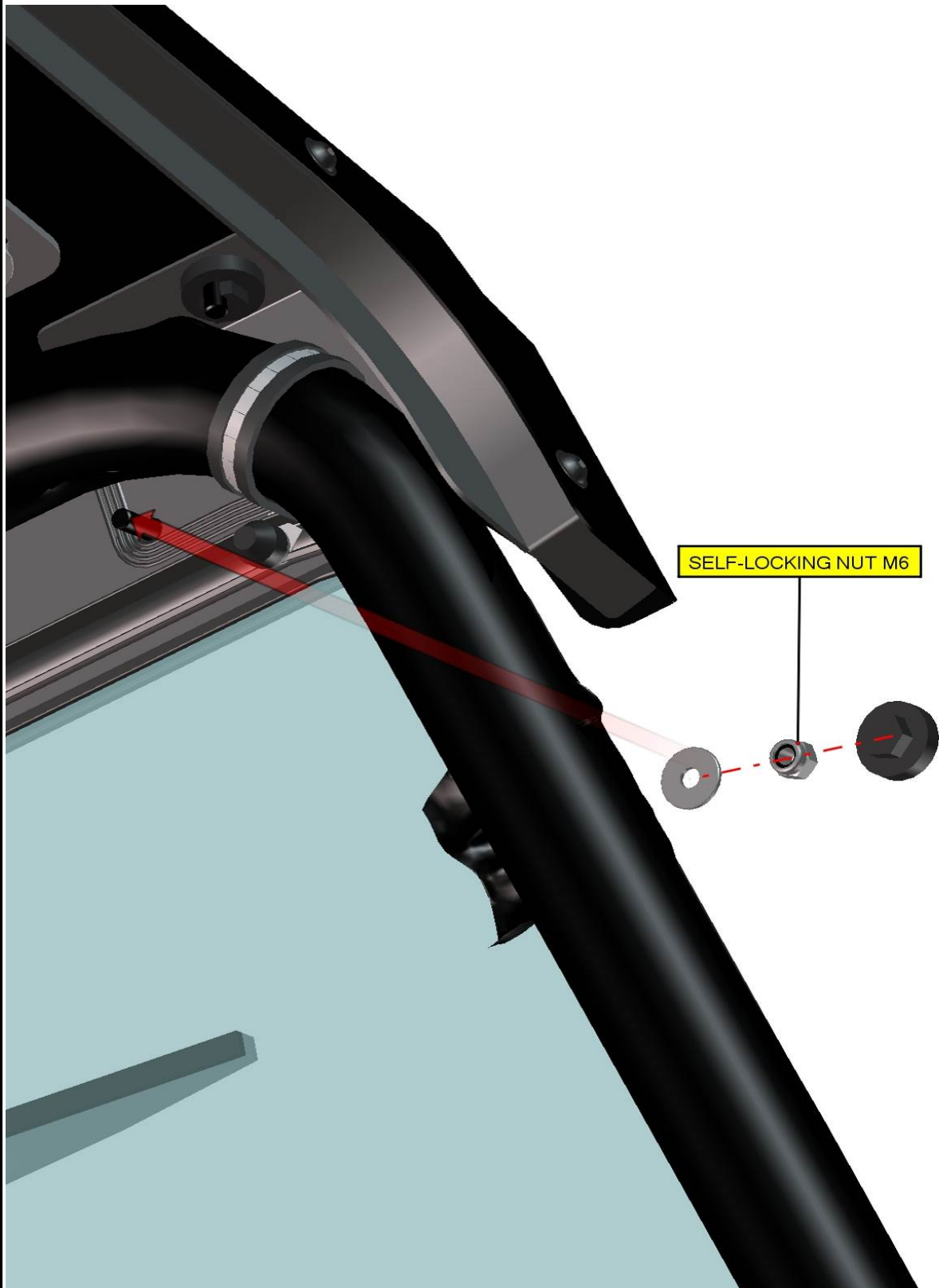

Adjust the holders to best position and tighten fast-lock handles.

FOR ALL TECHNICAL QUESTIONS, PLEASE CALL
DFK AMERICA INC.
(630) 324-8585

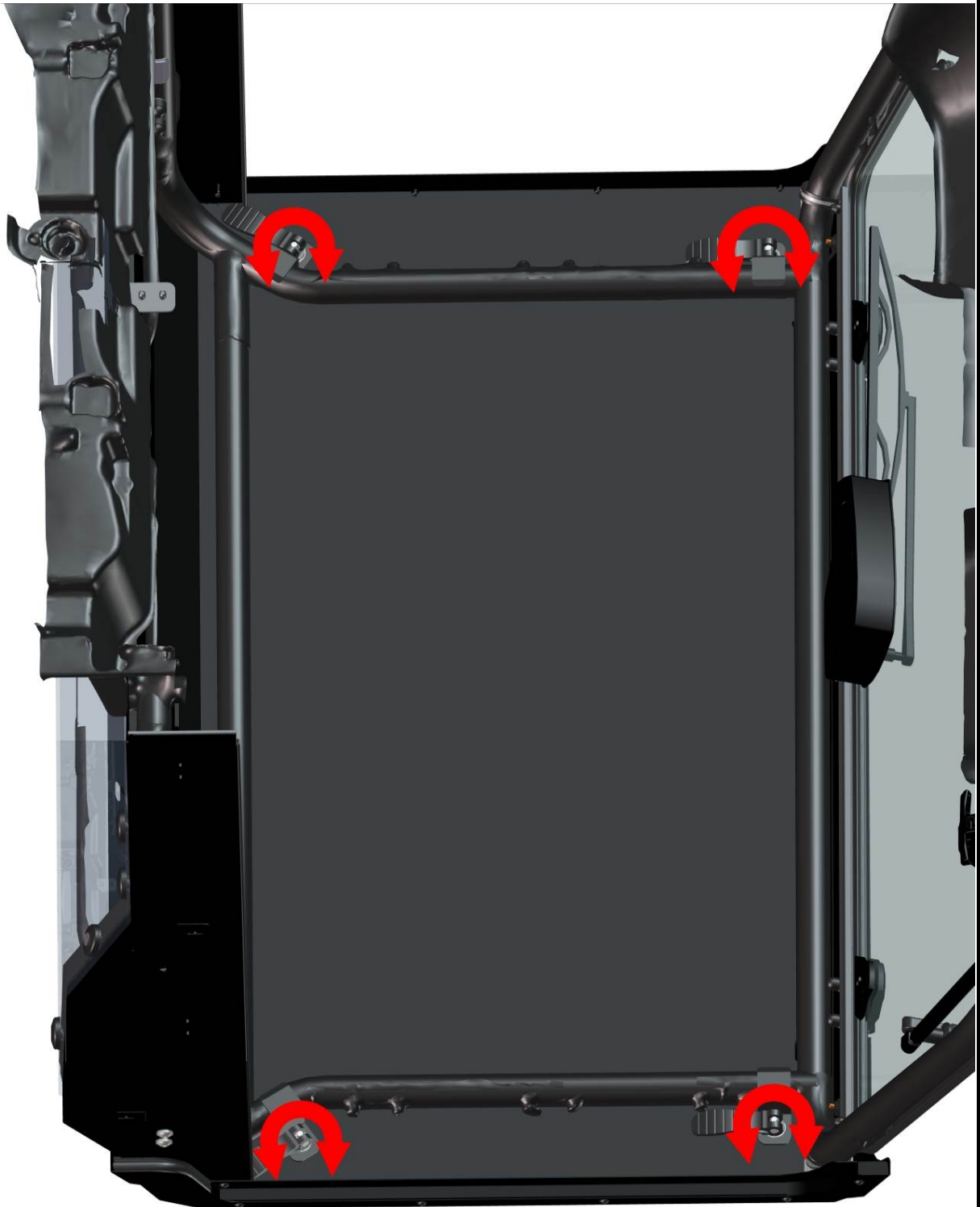

Tighten all screws and nuts on roof panel.

FOR ALL TECHNICAL QUESTIONS, PLEASE CALL
DFK AMERICA INC.
(630) 324-8585

HONDA BIG RED 2012

RIGHT DOOR

Place the door hinges onto the door base.

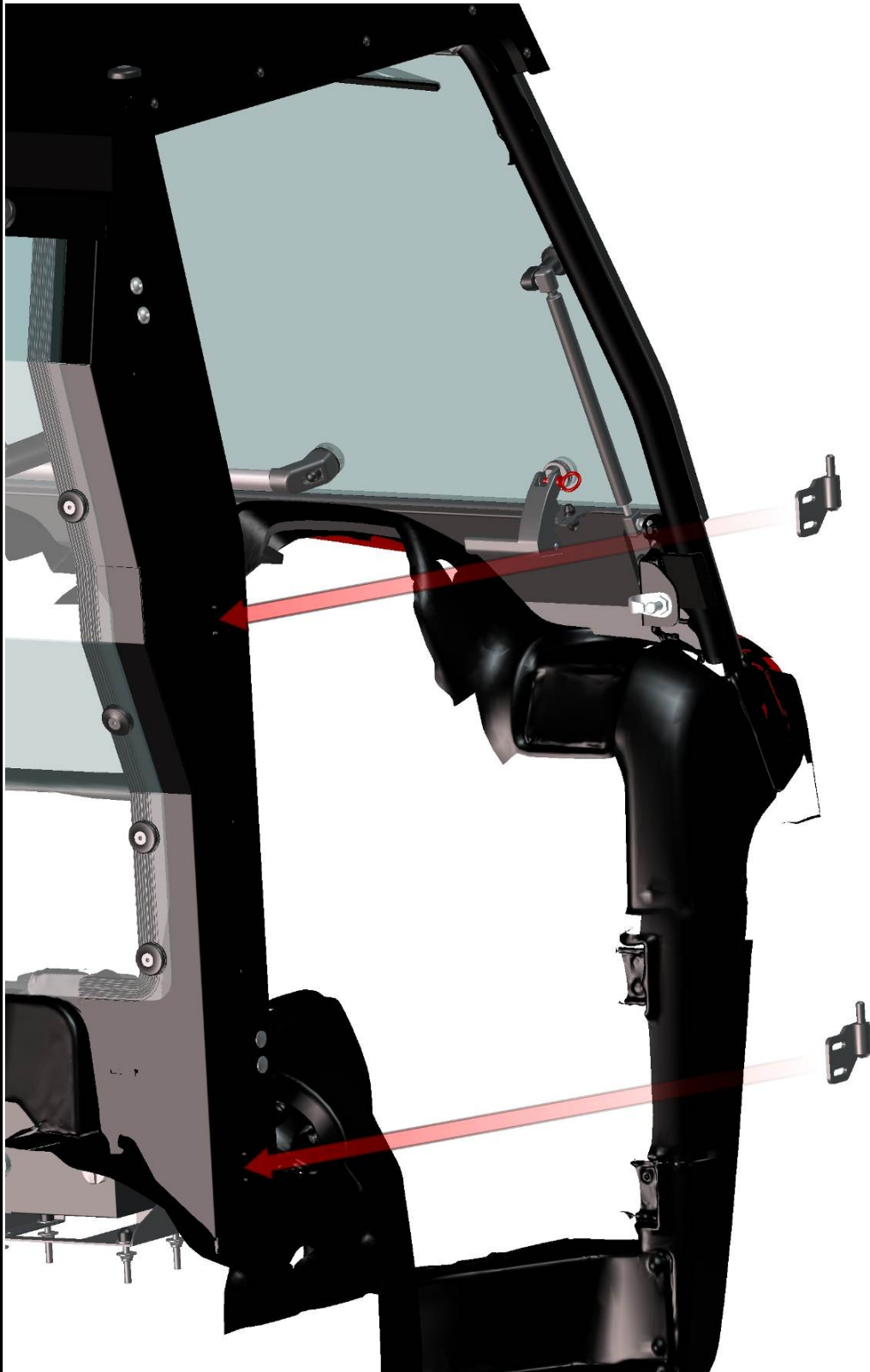

Fix the door hinges with the door base by screws, washers, nuts and nut covers.

FOR ALL TECHNICAL QUESTIONS, PLEASE CALL
DFK AMERICA INC.
(630) 324-8585

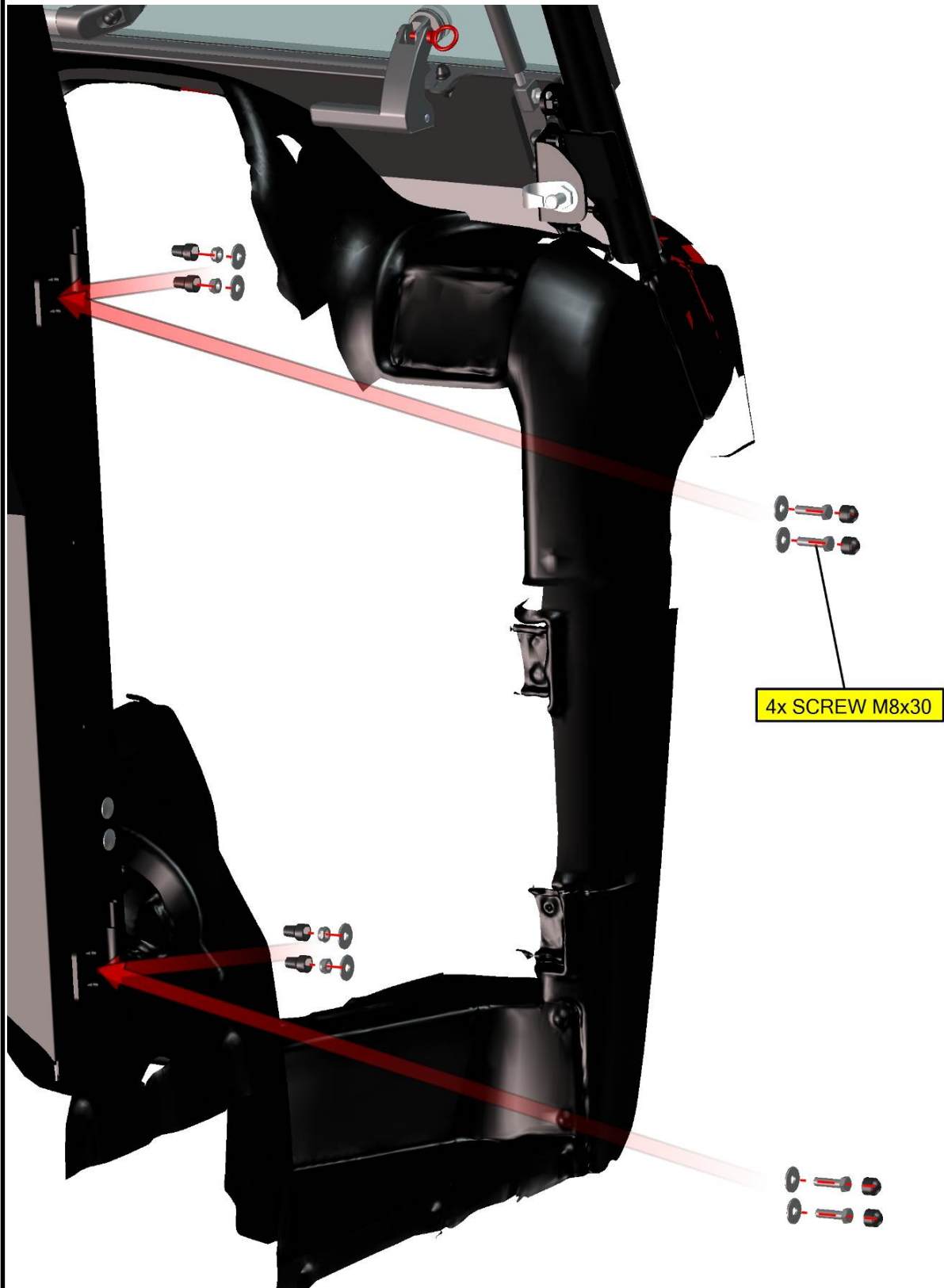

80

Lubricate the door hinge's pins and insert the washers on the pins.

FOR ALL TECHNICAL QUESTIONS, PLEASE CALL
DFK AMERICA INC.
(630) 324-8585

HONDA BIG RED 2012

Insert the door onto the hinges.

WASHER 10

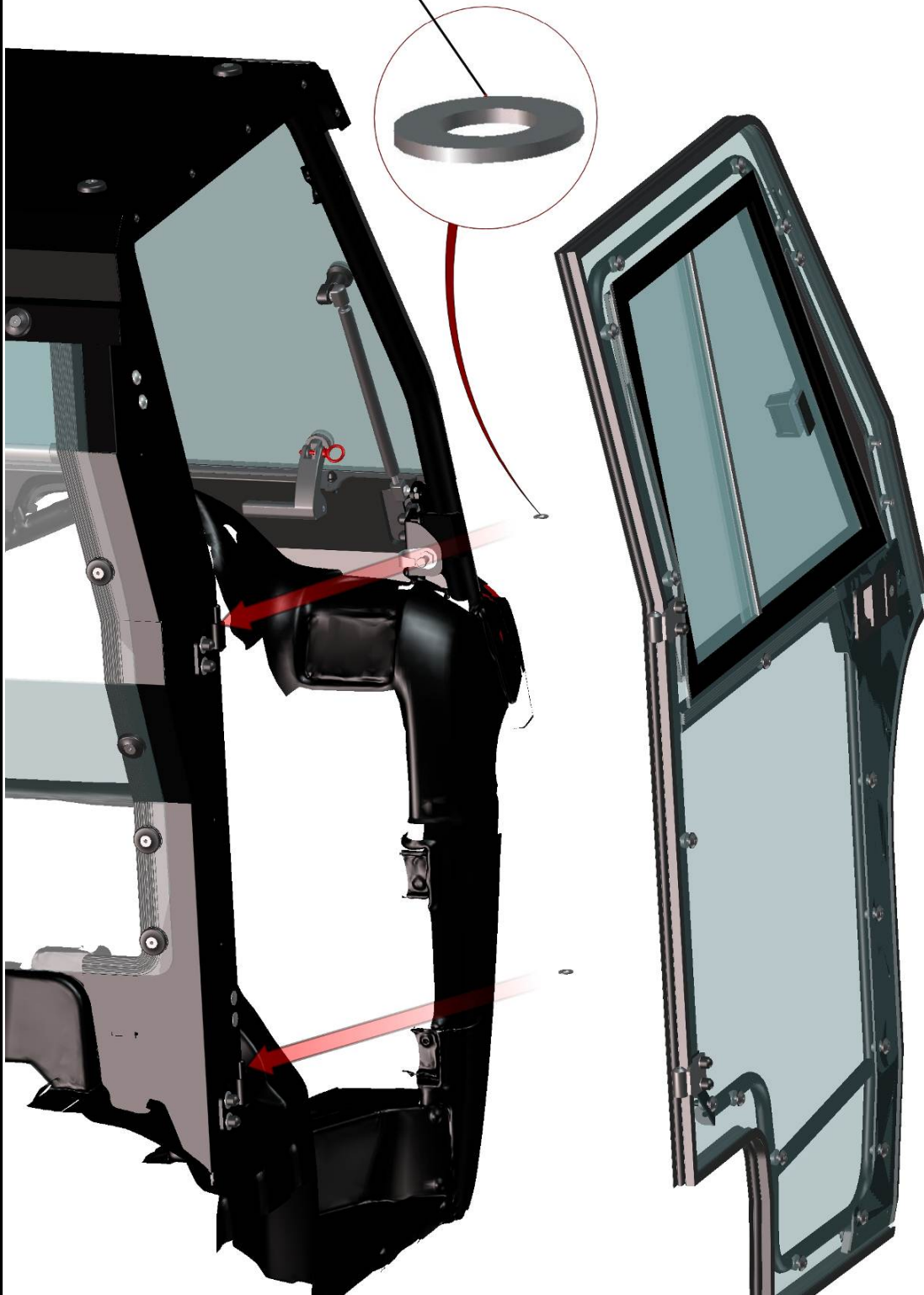

Adjust the door to best position (no gapes between the door and the UTV) and tighten the door hinge's screws and nuts hard.



Adjust the pin of door stop holder.

FOR ALL TECHNICAL QUESTIONS, PLEASE CALL
DFK AMERICA INC.
(630) 324-8585

If you close the door slowly and holder has been adjusted correctly, you can hear 2 clear metallic click.
If you have problems with adjusting the pin holders, adjust the door hinges again to better position.

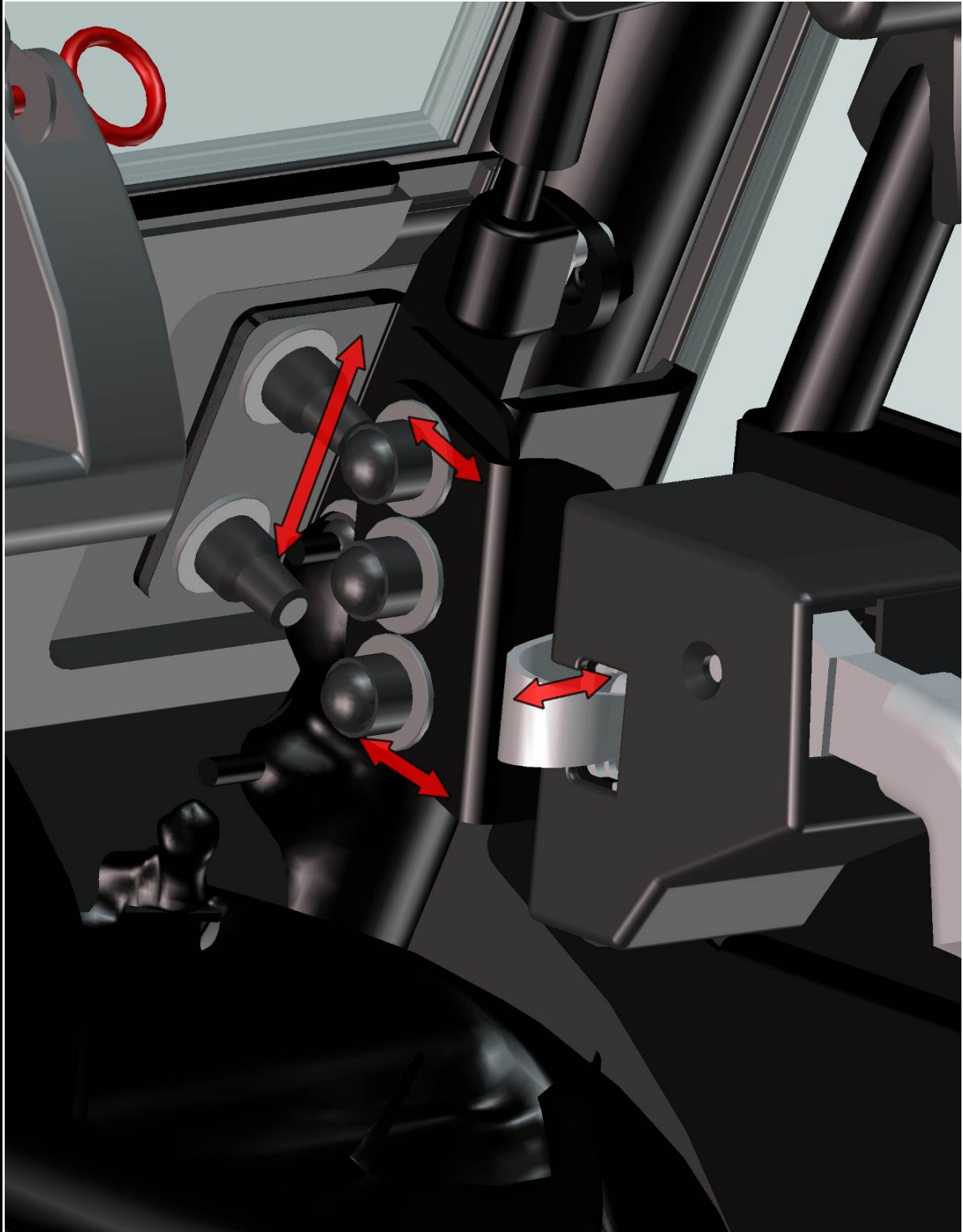

HONDA BIG RED 2012

Tighten the nuts (in red circles).



FOR ALL TECHNICAL QUESTIONS, PLEASE CALL
DFK AMERICA INC.
(630) 324-8585

Take out the screws and washer from door and place the rear mirror washer and rear mirror assembly onto the door panel. Fix the mirror and mirror washer with the door by screws from previous step.

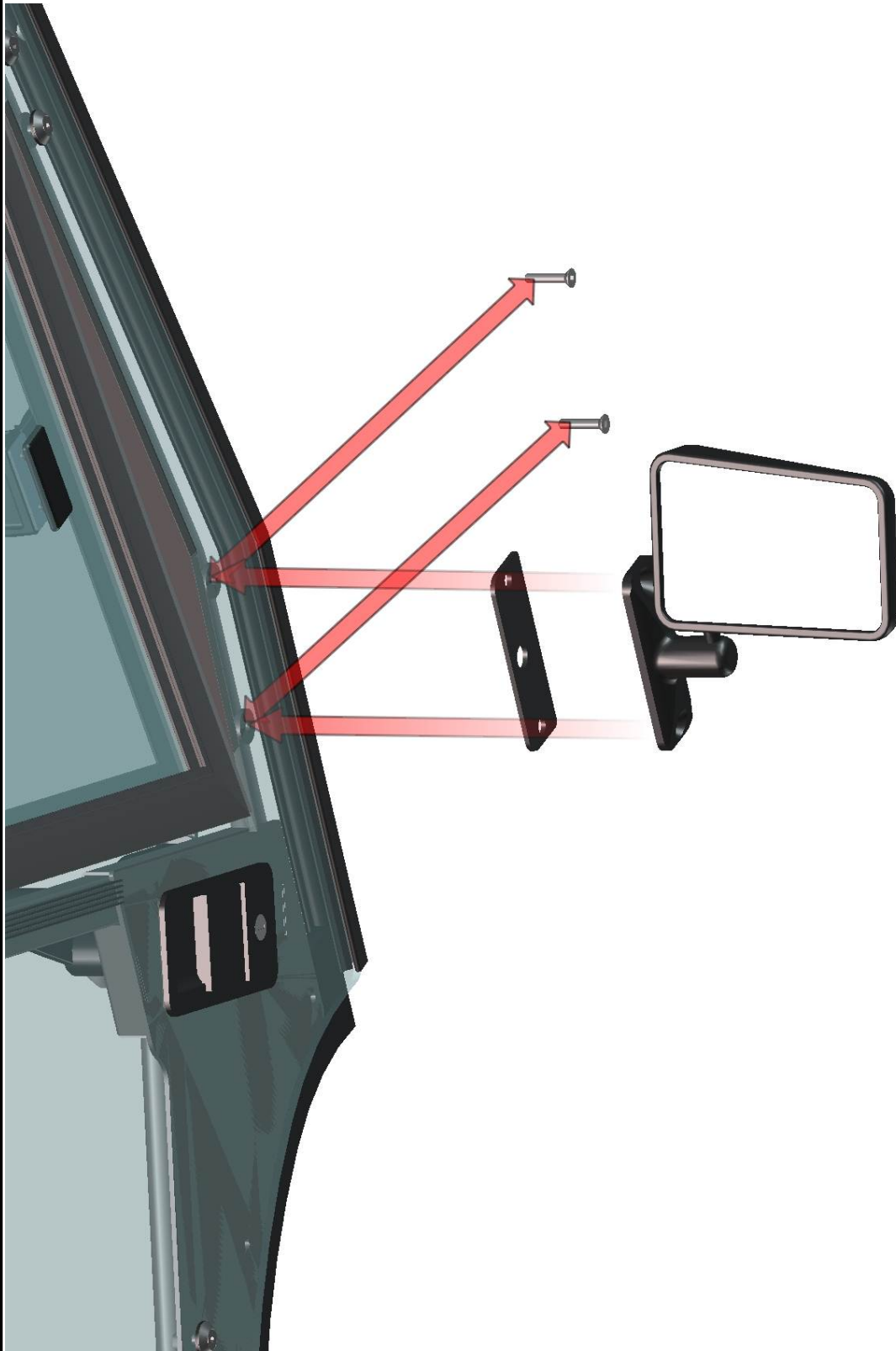

Adjust the rear mirror to best position.

FOR ALL TECHNICAL QUESTIONS, PLEASE CALL
DFK AMERICA INC.
(630) 324-8585



Take out nut covers and untighten nuts (in red circles), adjust the EPDM ledge on best position and tighten nuts. Place the nut covers back to nuts.

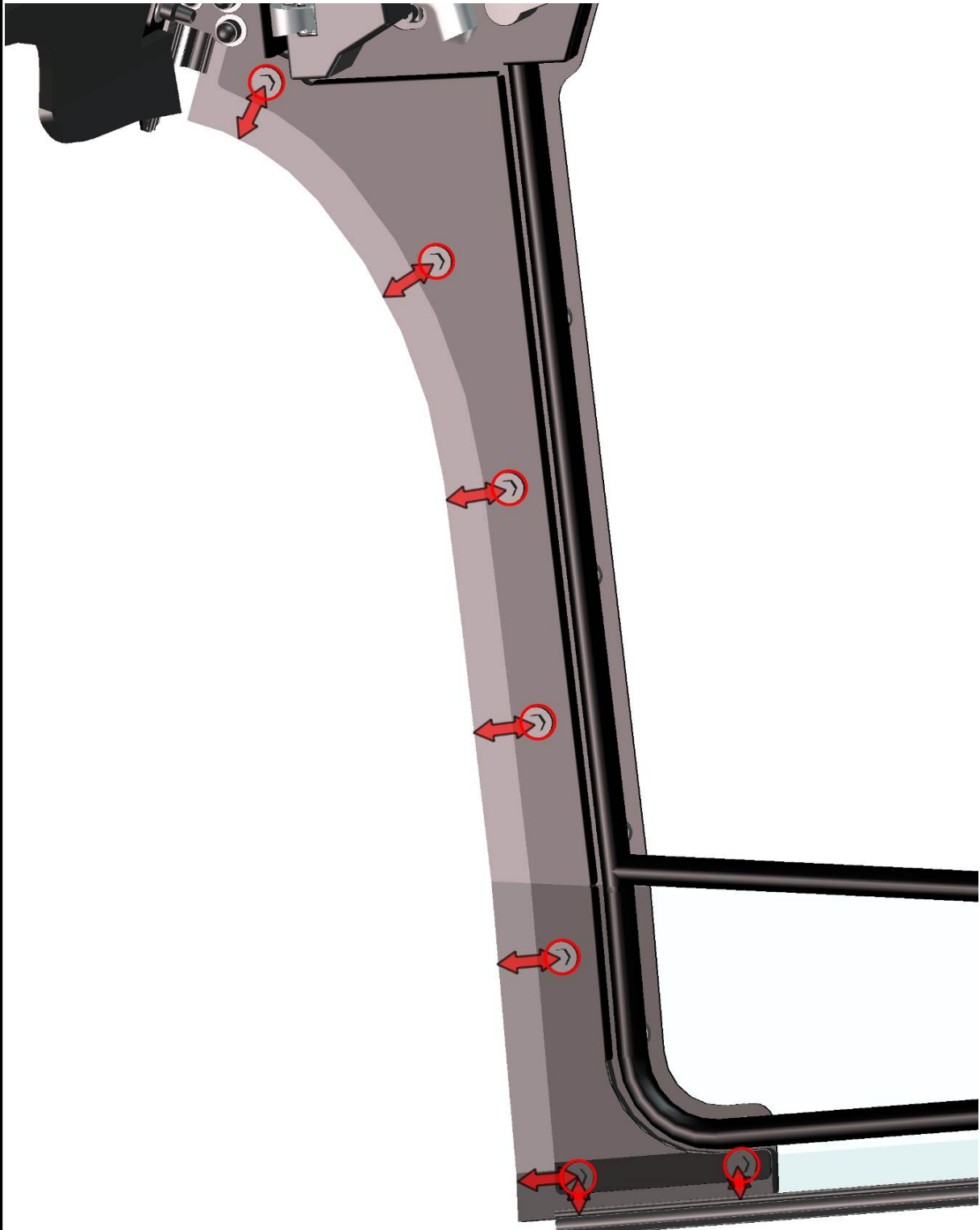

90

Installation of the left door is identical with installation of the right door.

Tighten all screws and nuts on cab and insert all nut covers.

ELECTROINSTALLATION

Overall wiring diagram (wiper, washer, heating).

Connect the wiper/ washer/heater harness with the UTV's electrification

(+ to the main UTV's switch, - earthed to the UTV'S frame).

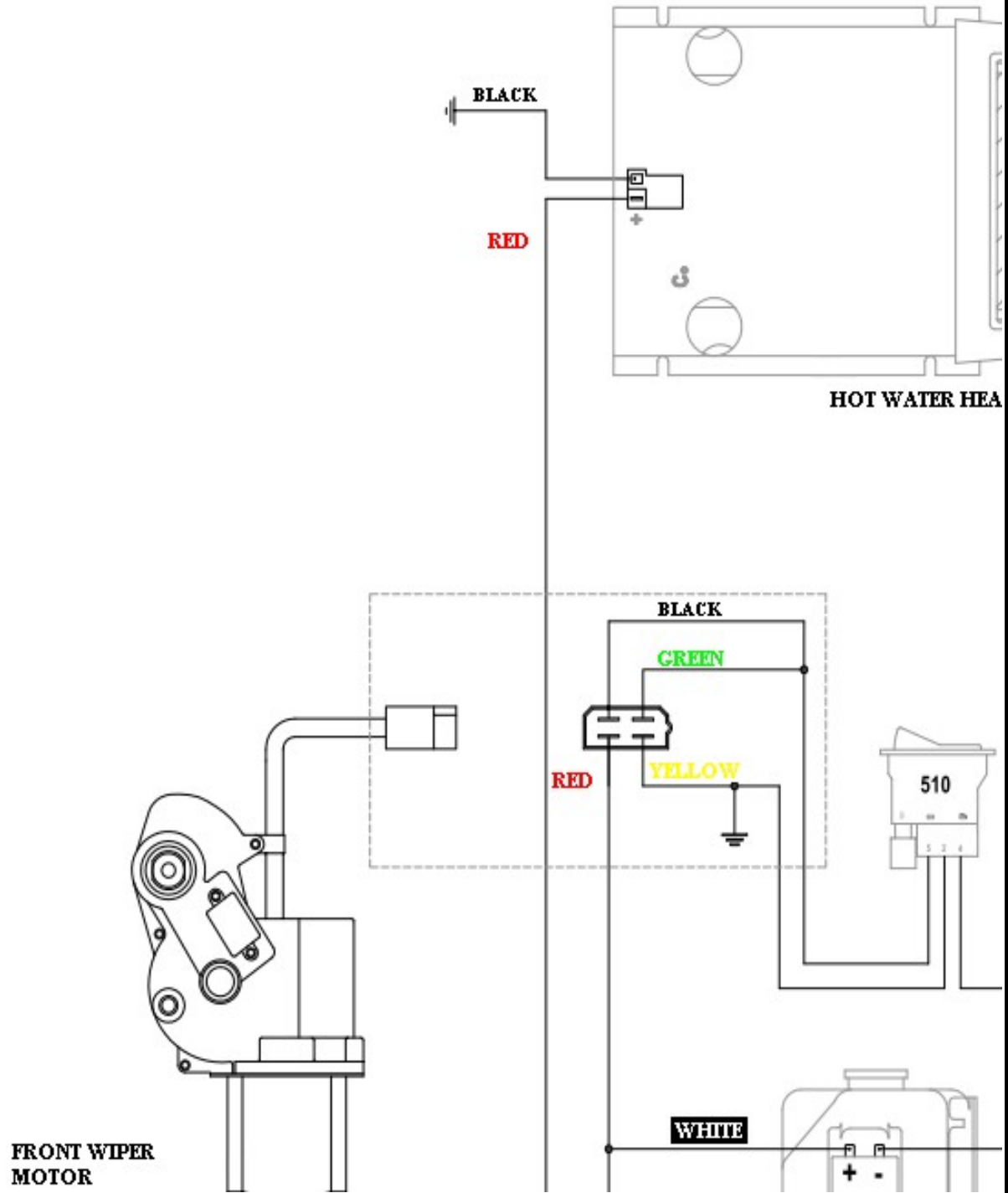

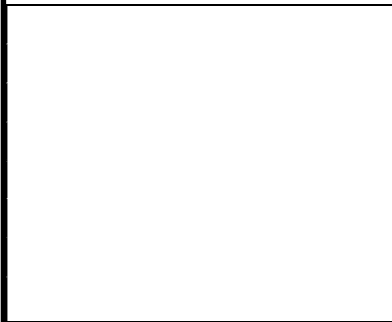

HEATER 12V



HARNESS WIPER

SWITCH WIPER/WASHER/OFF



HARNESS WASHER

WASHER TANK 12V



HARNESS HEATER

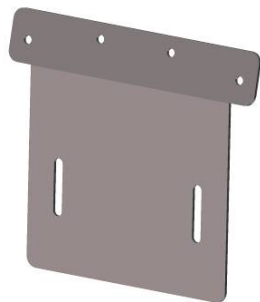

HEATER HOLDER WALL



HEATER HOLDER UNIVERSAL



TUBE 12mm/16mm

		
<p>METAL STRAP LARGE</p>	<p>METAL STRAP MEDIUM</p>	<p>"Y" COUPLING</p>
		
<p>WASHER TANK HOLDER</p>		

WIPER/WASHER INSTALLATION

Fix the washer tank holder with the UTV frame by original screw, and washer.



Install the washer tank onto the washer tank holder.



Lead the harness (red arrows) from washer tank to the main forklift switch electrification.

FOR ALL TECHNICAL QUESTIONS, PLEASE CALL
DFK AMERICA INC.
(630) 324-8585

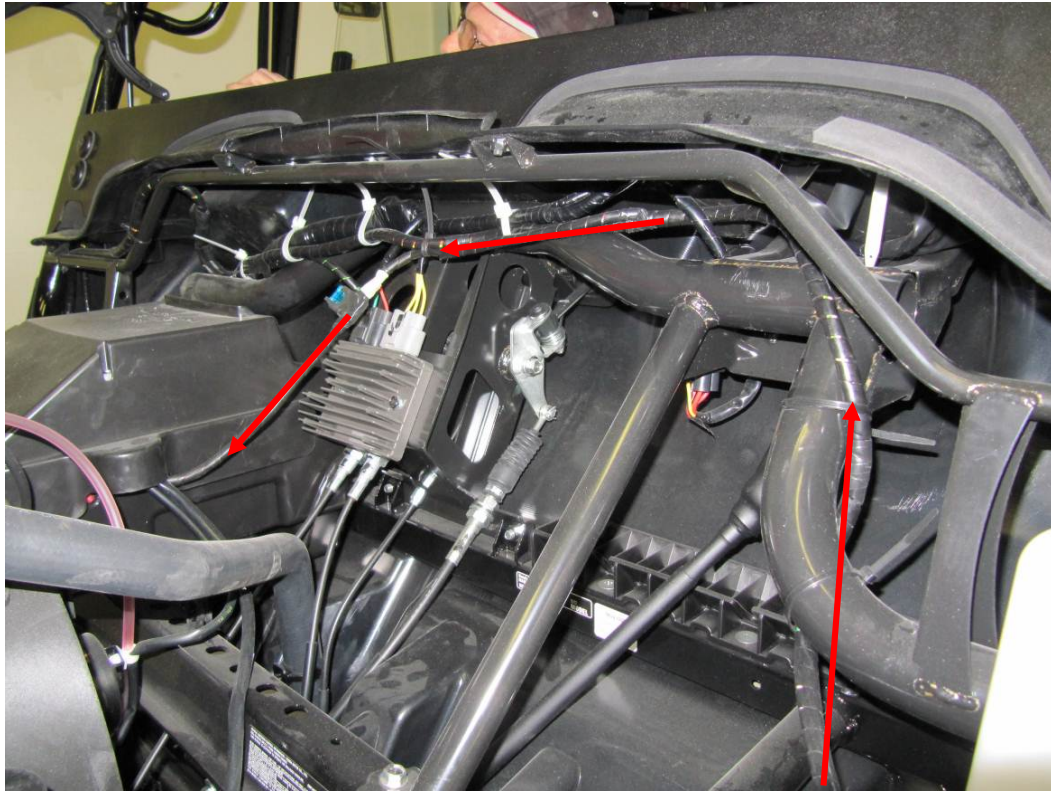

Connect the harness branch No.: 5 with the "+" 12V UTV's connector or cable.

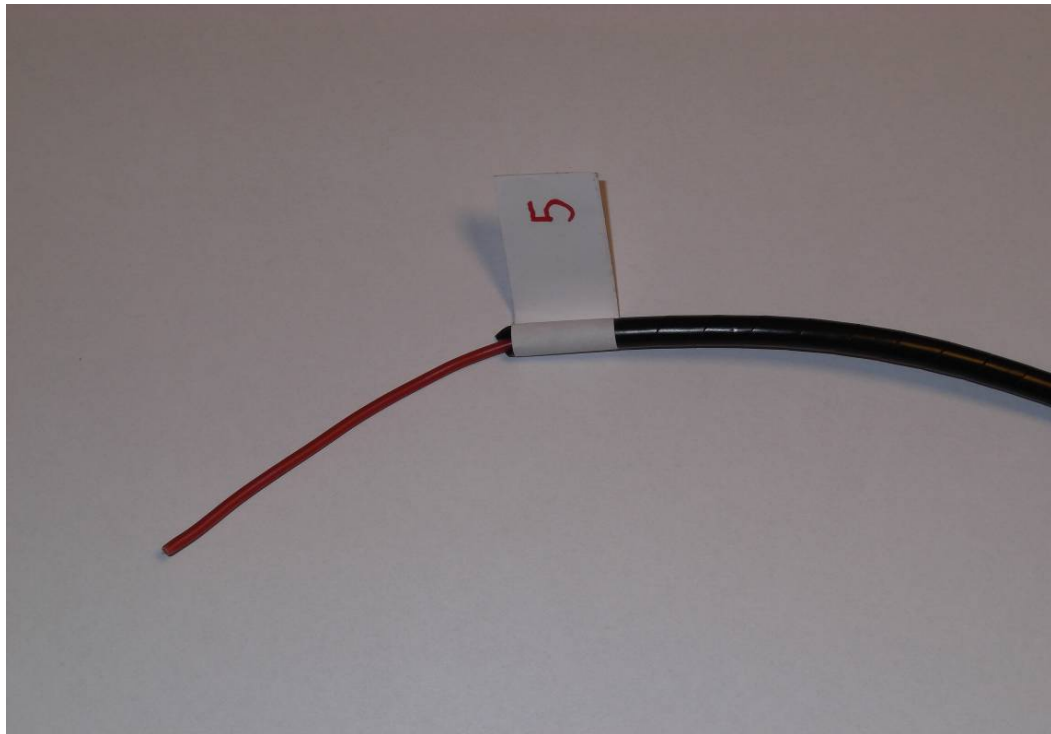

For connection you can use some of these connectors (included).

FOR ALL TECHNICAL QUESTIONS, PLEASE CALL
DFK AMERICA INC.
(630) 324-8585



After you connect the harness with the UTV's electrification don't turn UTV's main switch on yet.
Connect the harness branch No.: 2 with the UTV frame by original screw (in red circle).

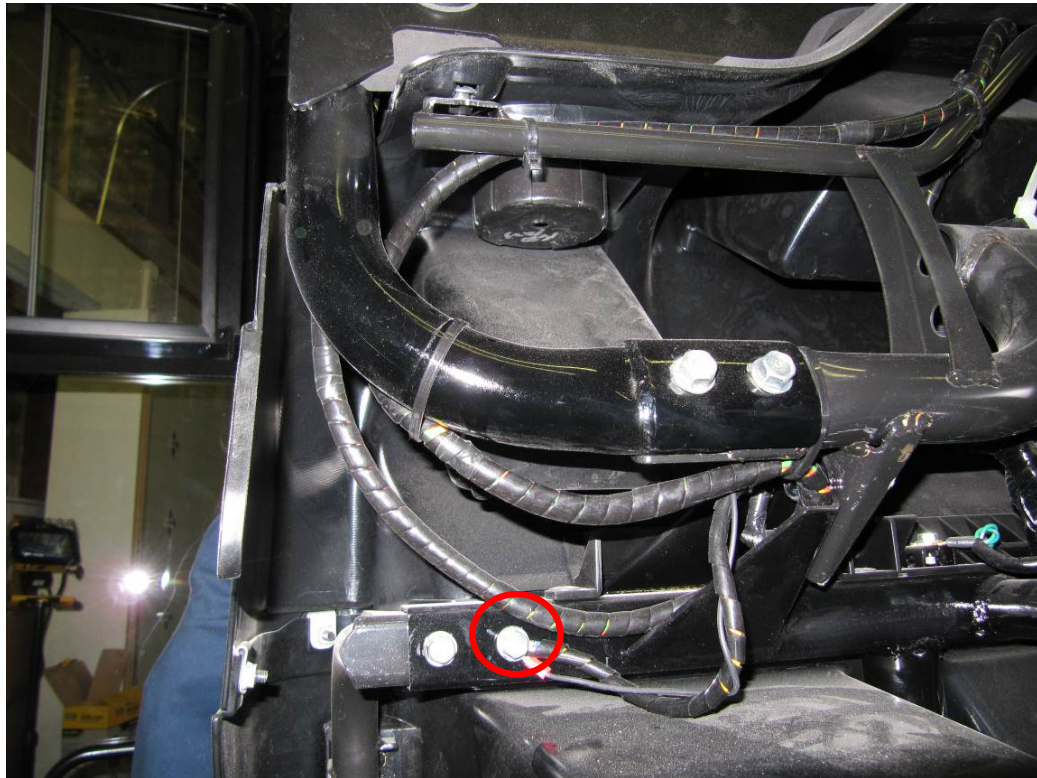

Lead the harness No.: 4 through the front dashboard cover.

FOR ALL TECHNICAL QUESTIONS, PLEASE CALL
DFK AMERICA INC.
(630) 324-8585

HONDA BIG RED 2012

If you don't have usable hole, drill that (red circle).



Detail view on harness branch

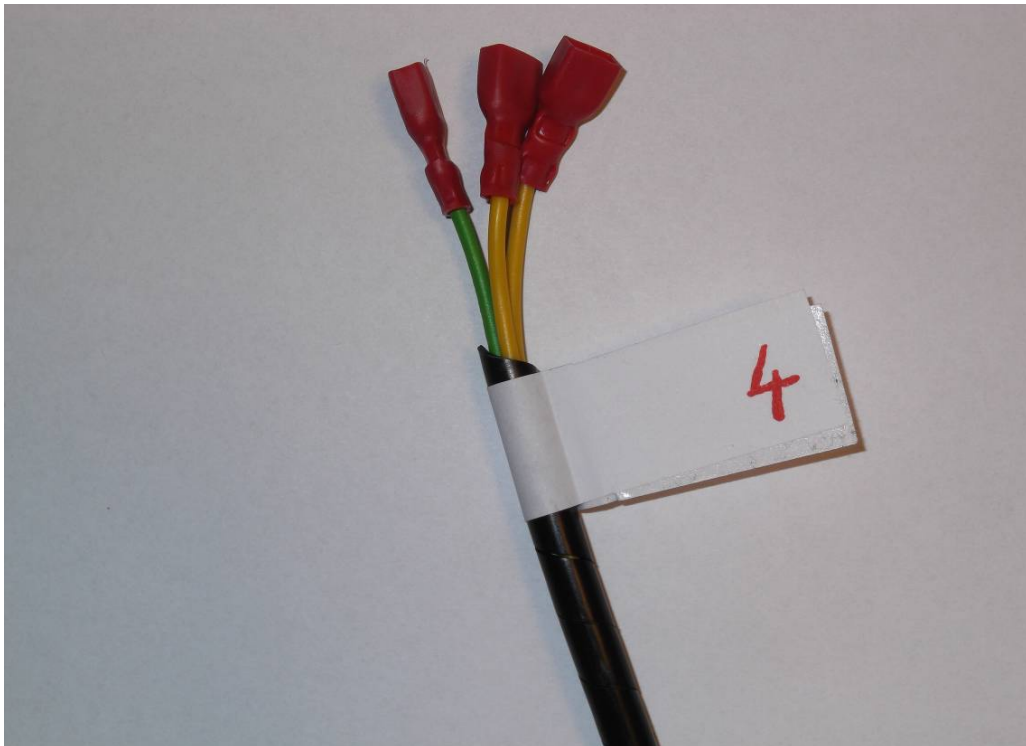

Cut the rectangle hole (red rectangle) onto the UTV's dashboard on correct position.

FOR ALL TECHNICAL QUESTIONS, PLEASE CALL
DFK AMERICA INC.
(630) 324-8585

HONDA BIG RED 2012



Pull the harness branch No.: 4 through the rectangle hole in dashboard, and connect the branch with switch (detail of connection).



FOR ALL TECHNICAL QUESTIONS, PLEASE CALL
DFK AMERICA INC.
(630) 324-8585

Insert the switch into the hole in the dashboard. Lead the harness branch No.: 1 to the right front UTV's roller cage.

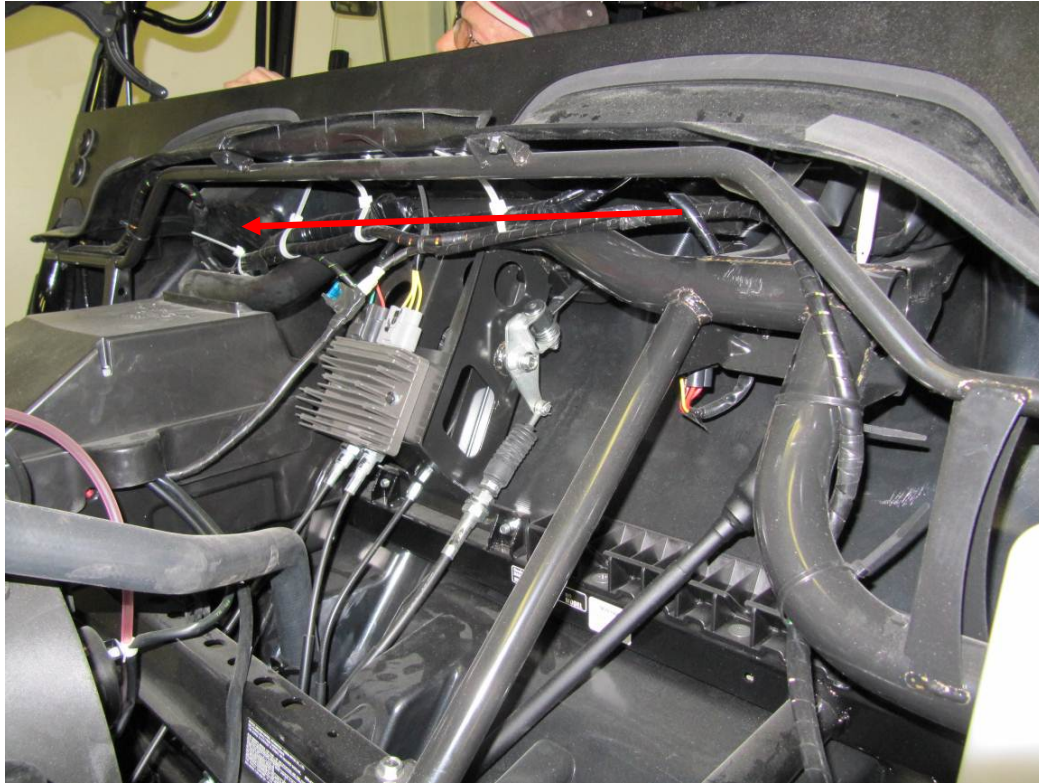

Detail view to the harness branch.

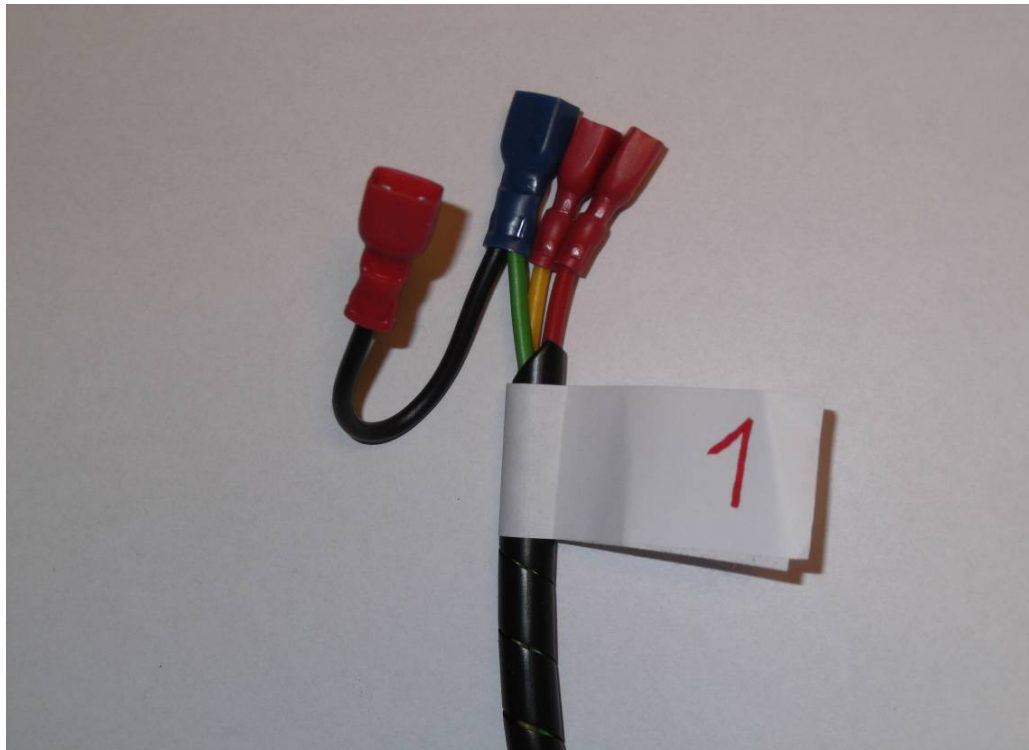

FOR ALL TECHNICAL QUESTIONS, PLEASE CALL
DFK AMERICA INC.
(630) 324-8585

Lead the harness branch (red arrow) from previous page through the hole (red ellipse) between roller cage and dashboard and on the roller cage. If that hole is too small, cut them to correct size.



101

HONDA BIG RED 2012

Lead the harness branch No.:1 (red line) around the roller cage to the wiper motor.
Fix the harness with the roller cge by plastic tightening straps.

102



103

Uninstall the wiper motor cover and connect the harness branch with the wiper motor connector.

FOR ALL TECHNICAL QUESTIONS, PLEASE CALL
DFK AMERICA INC.
(630) 324-8585

Detail view of connection.

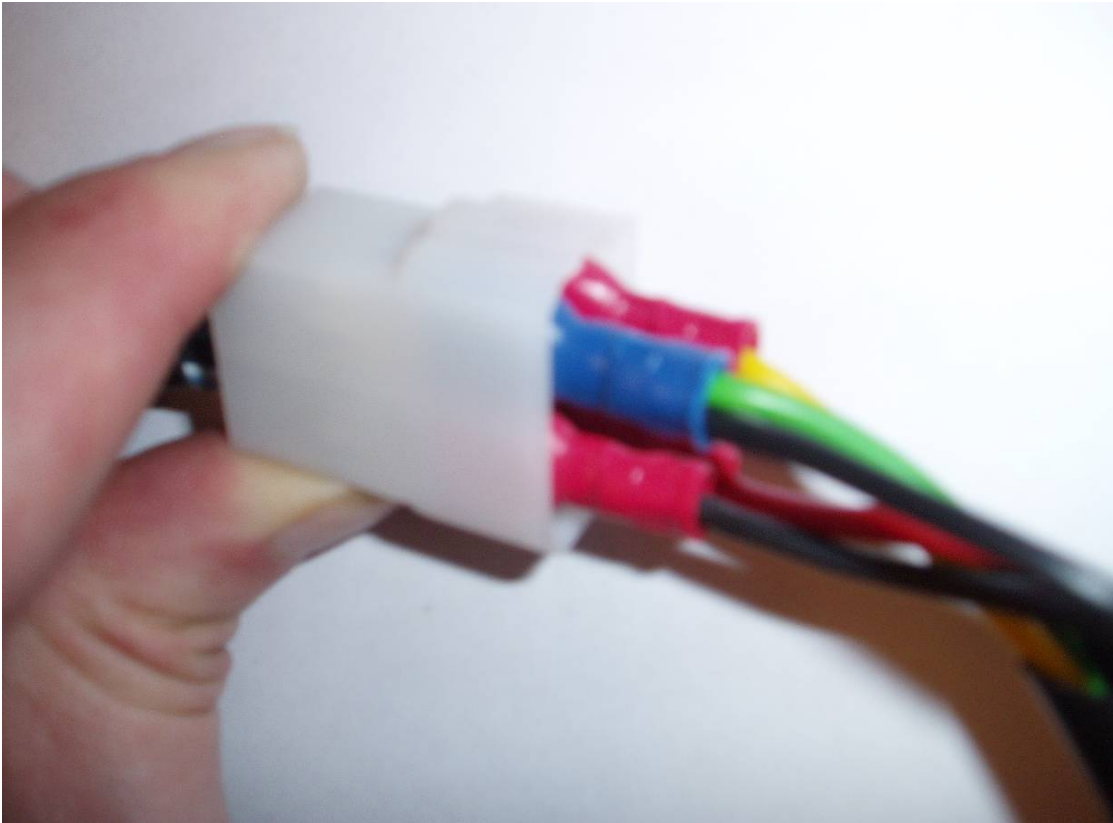

Pull the washer hose through the front panel bushing and the roof bushing and connect the hose with the washer jet.

(You may by have to install the washer jet onto the wiper arm.)

Fill the water to the washer tank before starting usage.

HEATER INSTALLATION

FOR ALL TECHNICAL QUESTIONS, PLEASE CALL
DFK AMERICA INC.
(630) 324-8585

IMPORTANT

IT IS ABSOLUTELY NECESSARY TO TAKE OUT THE RUBBER PLUGS FROM THE HEATER TUBES!!!

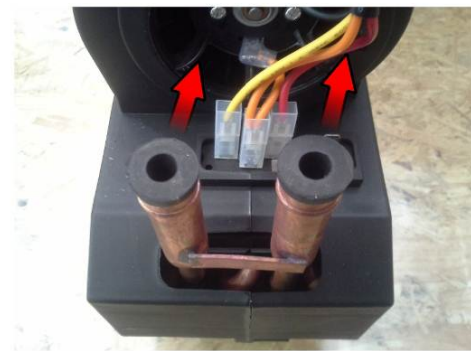
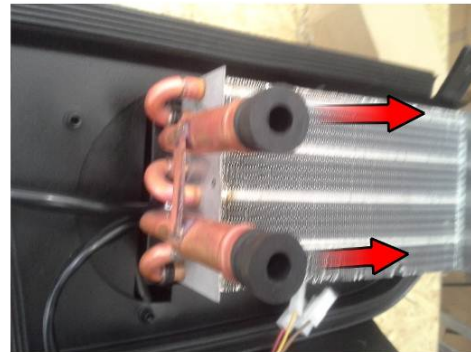
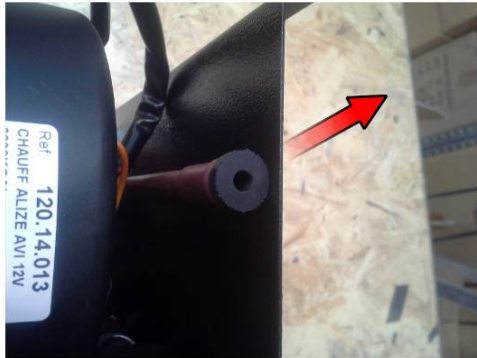

The heater has been install onto the front bottom dashboard.

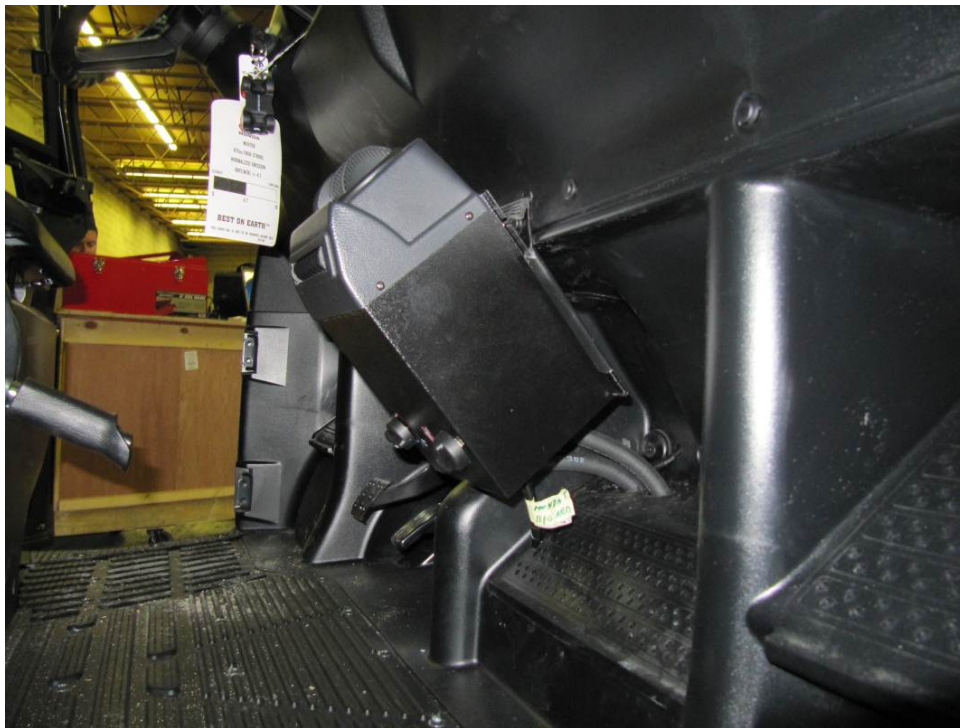

FOR ALL TECHNICAL QUESTIONS, PLEASE CALL
DFK AMERICA INC.
(630) 324-8585

Connect the heater hoses inner \varnothing 12mm with the heater (see next picture).

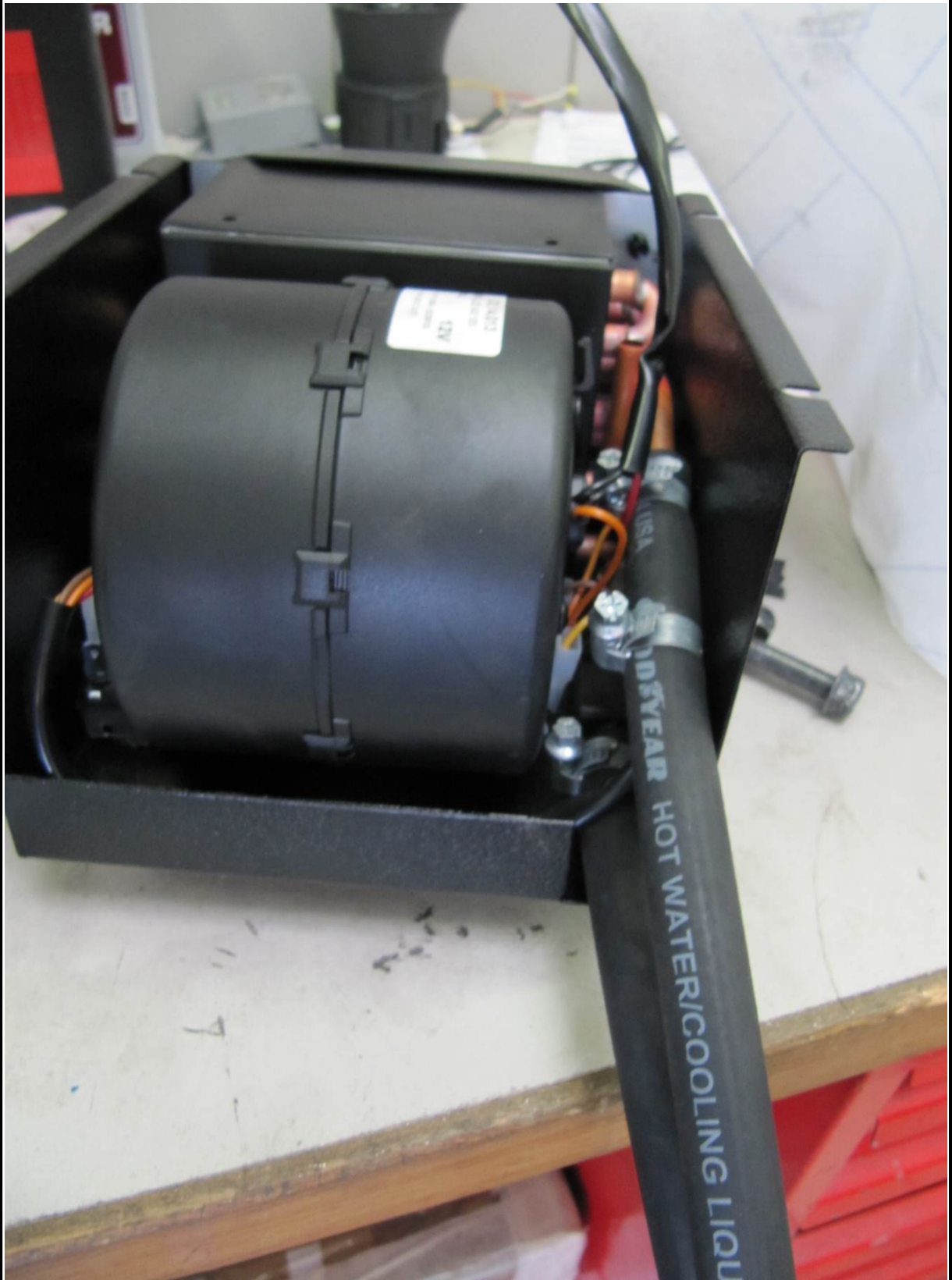

107

FOR ALL TECHNICAL QUESTIONS, PLEASE CALL
DFK AMERICA INC.
(630) 324-8585

Install the heater with correct holders onto the dashboard in correct position.



Fix the holder universal with the holder wall, fix the holders with the UTV's wall (you have to drill 2 holes $\varnothing 11\text{mm}$ (0,43 in)) and insert heater on holder.

108

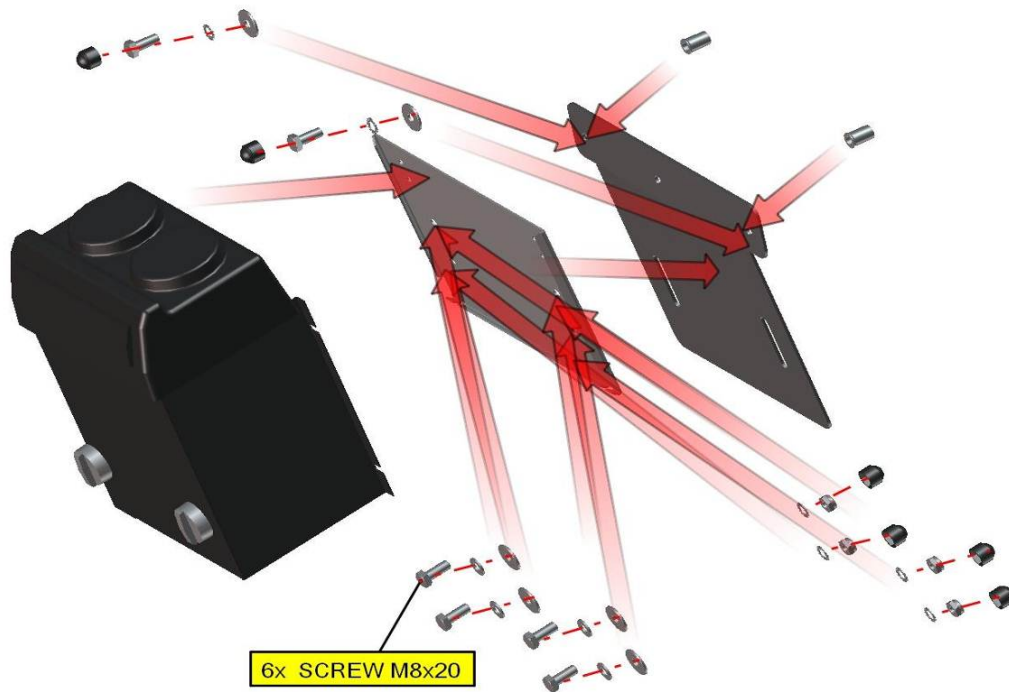

Lead the harness branch No.: 3 from the main UTV's switch to the heater through the dashboard.

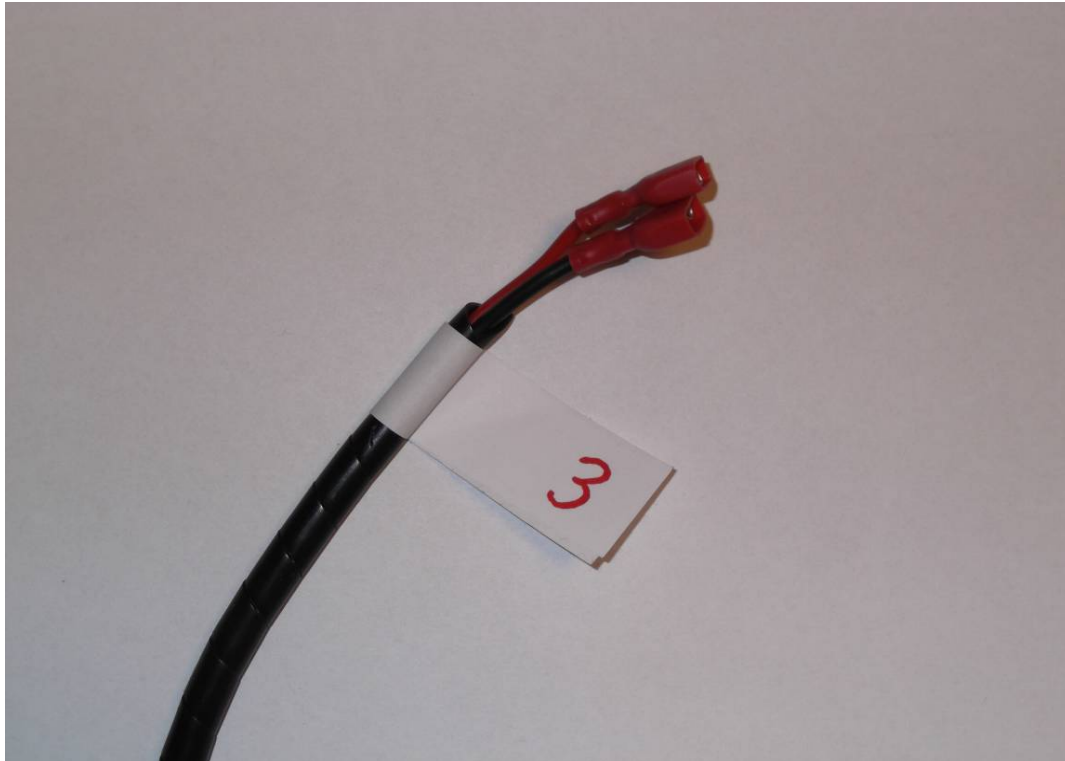

Connect the harness branch No.: 3 with the heater (detail view).

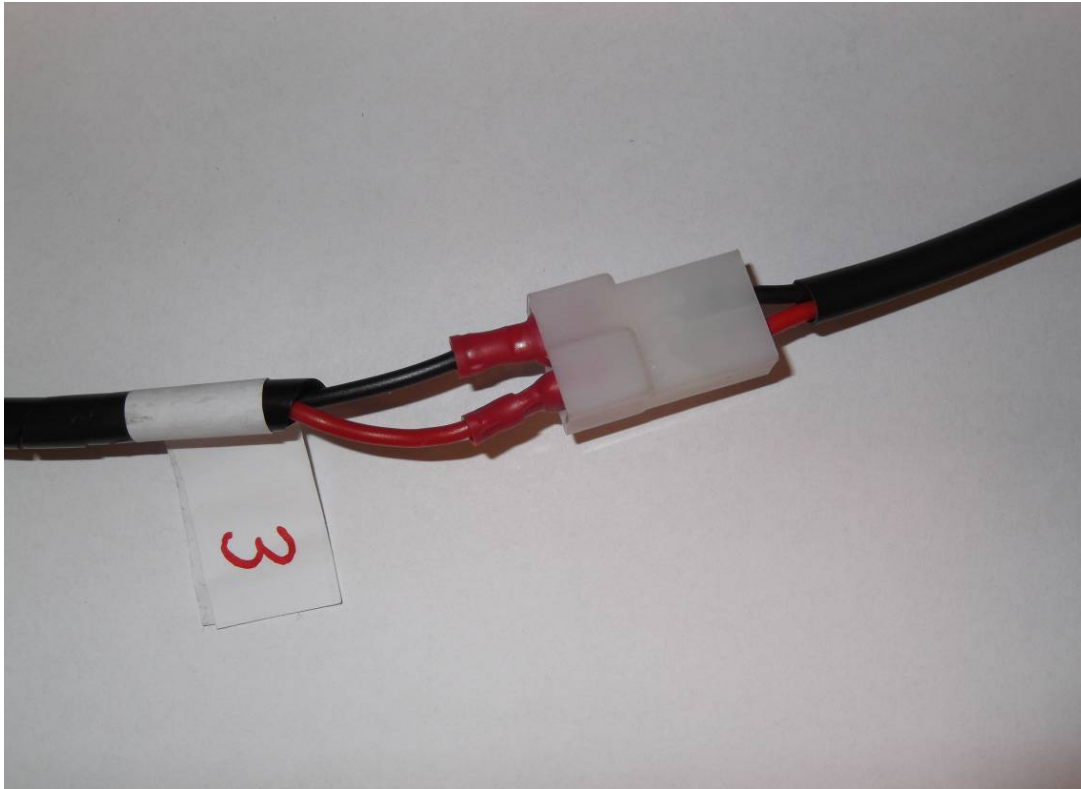

Connect harness branch No.: 1 and 2 with the UTV's battery.

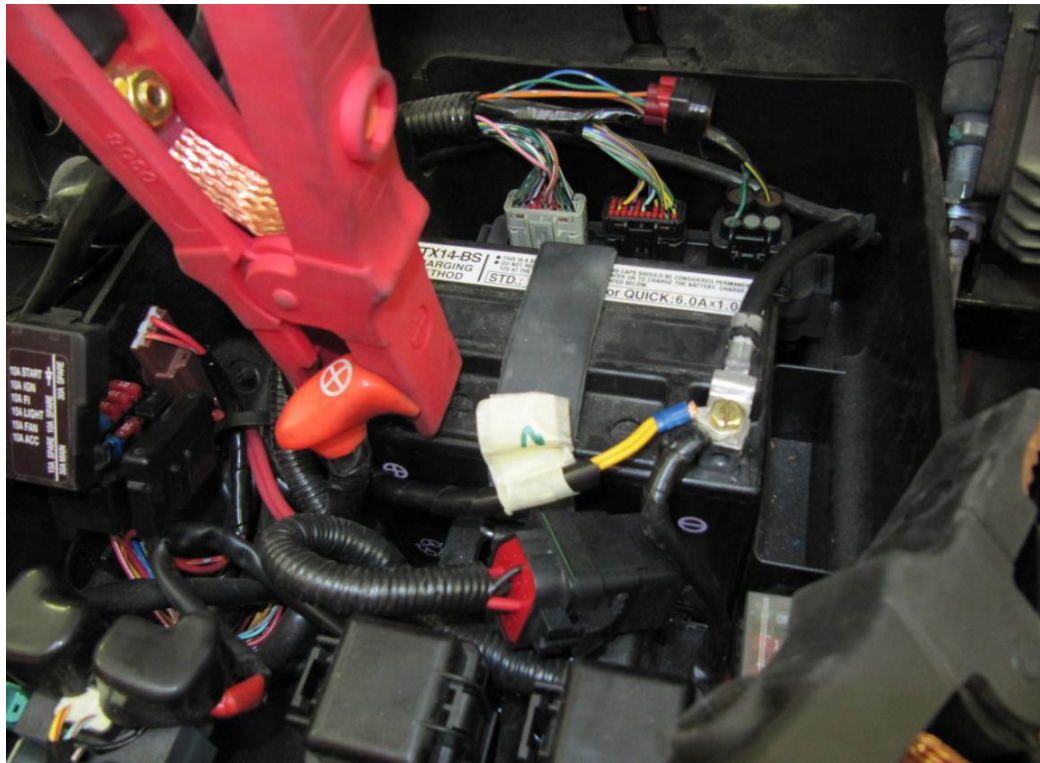

FOR ALL TECHNICAL QUESTIONS, PLEASE CALL
DFK AMERICA INC.
(630) 324-8585

You have to cut 2 holes \varnothing 20-23 mm (*0,79-0,91in*) for the water hoses in plastic covers under the heater.



Insert the tubes 12mm/16mm into the hoses \varnothing 12mm and into the hoses \varnothing 16mm (in the floor tunnel space) and tighten that hard by metal straps medium on both sides.



Lead the water hoses (red arrow) from the heater to the UTV's engine space (see next page).
Cut the hoses longer 10-15inchs more as you need.

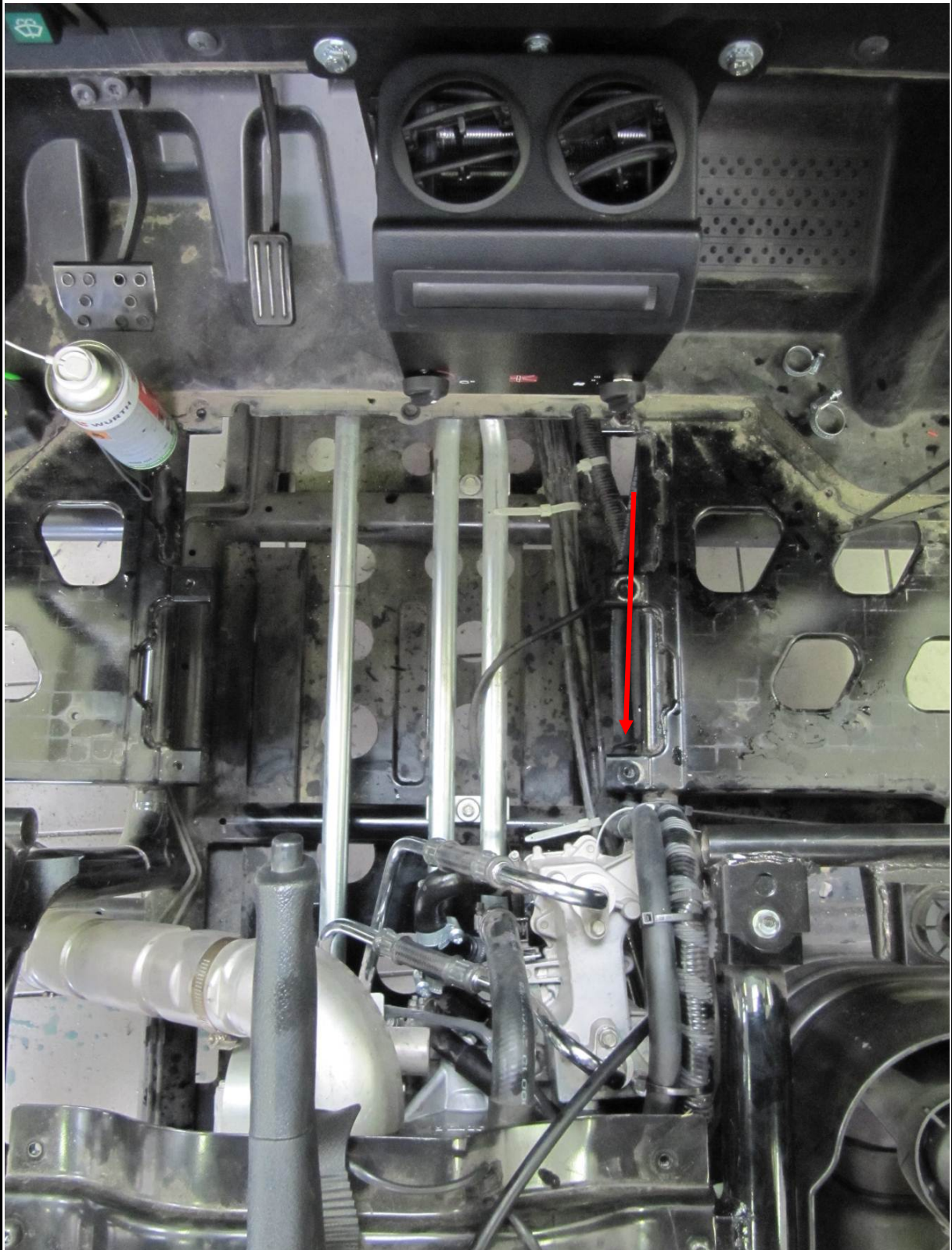

113

Lock the original hose by clamps, and cut that. Insert tightening straps onto the hose

FOR ALL TECHNICAL QUESTIONS, PLEASE CALL
DFK AMERICA INC.
(630) 324-8585

HONDA BIG RED 2012

and insert the "Y" coupling (red circle) into the hose.



Insert the tightening strap into the hot water heater connected with the heater valve, and insert the hose onto the "Y" coupling. Tighten these straps very hard.

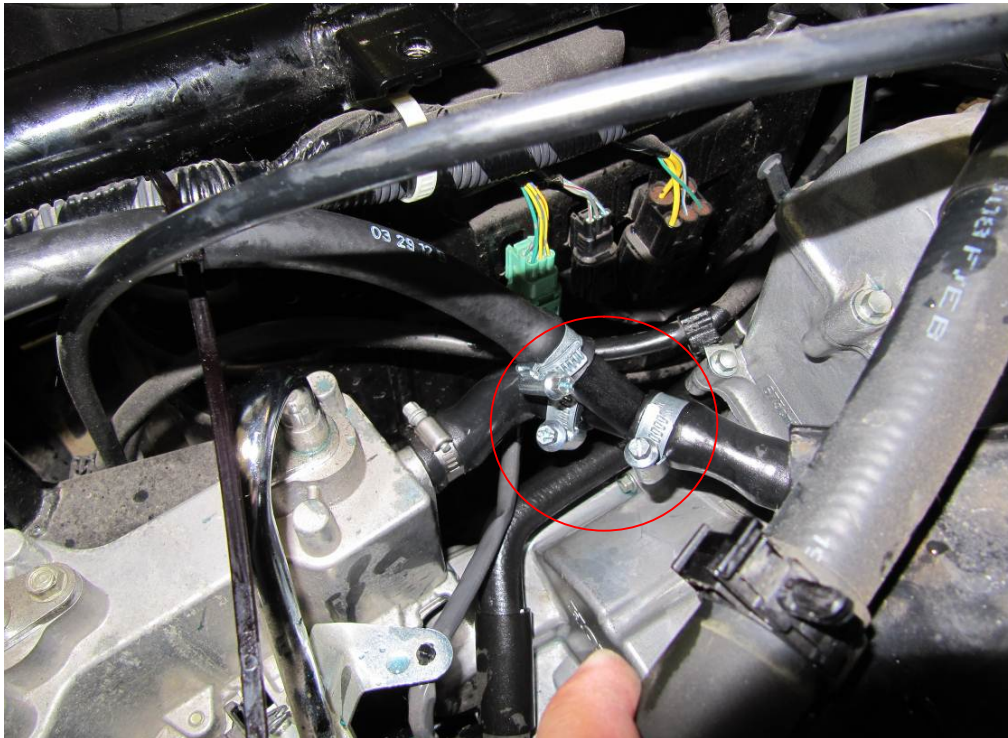

FOR ALL TECHNICAL QUESTIONS, PLEASE CALL
DFK AMERICA INC.
(630) 324-8585

HONDA BIG RED 2012

Lock the original hose by clamps.

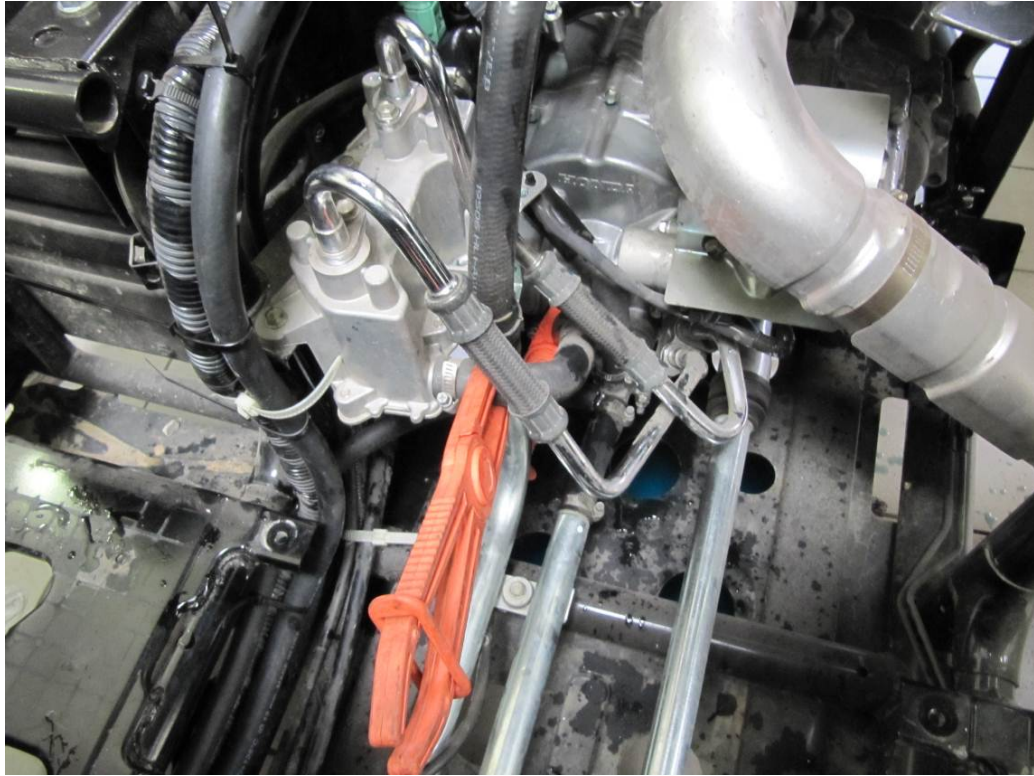

Different side view.

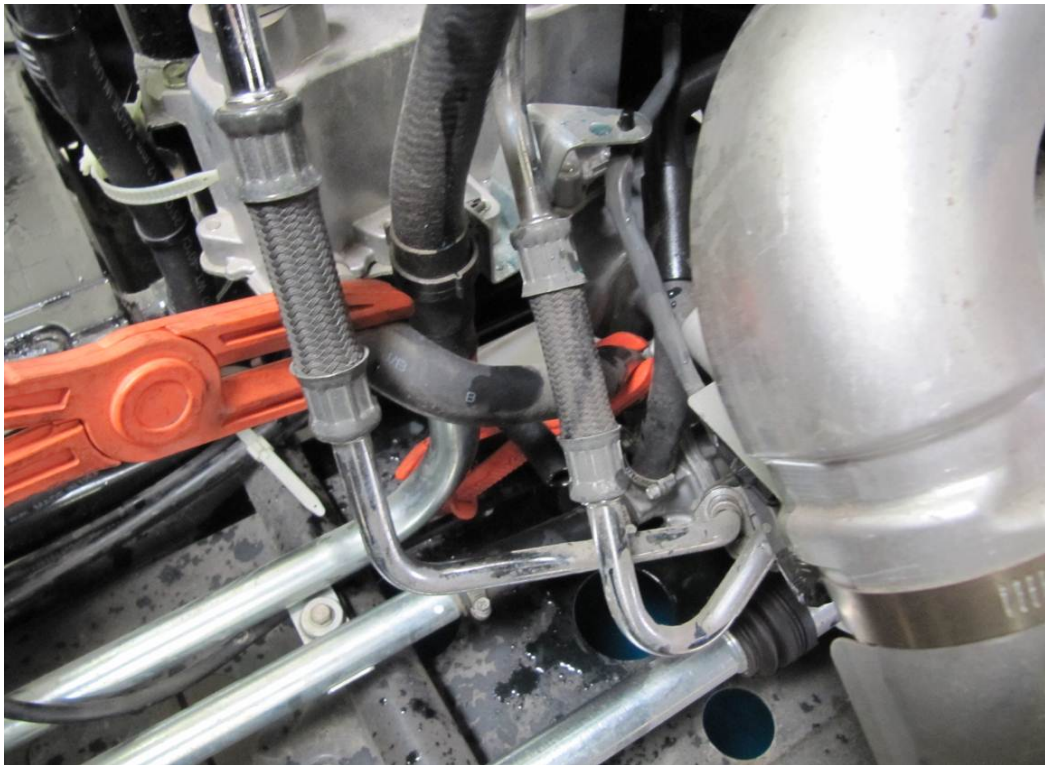

FOR ALL TECHNICAL QUESTIONS, PLEASE CALL
DFK AMERICA INC.
(630) 324-8585

Insert tightening straps onto the hose and insert the "Y" coupling (red circle) into the hose.
Insert the tightening strap into the second hot water heater,
and insert the hose onto the "Y" coupling. Tighten these straps very hard. Take out the clamps from hoses.



Take out the heater from the holder and lay that onto the UTV's floor.
Loosen original screw and use that for bleeding out the cooling system.



FOR ALL TECHNICAL QUESTIONS, PLEASE CALL
DFK AMERICA INC.
(630) 324-8585

SEE NEXT PAGE

After you bled out the cooling system correctly, install the heater back to holder and tighten original screw from previous page. Install back all plastic parts and fix these by original screws.

Before the first turning on the hot water heater it is necessary to check the tightness of the cooling circuit of the hot water heater.

If necessary add more cooling liquid to the cooling circuit.

Please note that additional heater system will absorb more than 2 liters of coolant fluid.

Turn off heater and add more cooling liquid to the cooling circuit if need it.