



*INSTALLATION INSTRUCTIONS*

**POLARIS RANGER**  
**800 XP**



**4x4**



**6x6**

## **SAFETY INSTRUCTIONS**

***Warning: Failure to heed all safety and operating instructions and warnings regarding use of this product can result in serious bodily injury.***

### **READ PROPERLY COMPLETE ASSEMBLY INSTRUCTIONS BEFORE STARTING OF ASSEMBLY**

***Install all parts indicated in assembly instructions. Failure to fully assemble product before use could result in personal injury.***

***Assembly of product requires use of hand or power tools. If you are not experienced in using these types of tools, have product dealer do the install for you.***

***Some parts contain sharp edges, wear protective gloves if necessary.***

***Always keep your assembly area clean, uncluttered and well lit.***

***Keep visitors and children a safe distance away from the assembly area. Visitors should wear the same safety equipment described under.***

***Never operate your UTV with the cab doors open. Failure to properly latch the doors before moving the vehicle could result in serious injury.***

***Dress for safety. DO NOT wear loose clothing, gloves, neckties or jewelry if using power tools to assemble this product.***

***Tight the front glass holders screws with attention, if you tight these screws too hard the front glass may by crackle.***

***Insert all nut covers after you finish installation.***

***Never drive your UTV with the cab front window in open position. Failure of improperly latched/locked front window before driving the vehicle could result in serious injury.***

## **MAINTENANCE AND CLEANING**

*To clean polycarbonate surface use soapy water solution or other subtle means.*

*Dirt and dust wash by gently water stream and swipe only with wet or damp means in the direction from top to bottom.*

*The recommended frequency of cleaning of polycarbonate part is about 1 time per month or according to the actual degree of pollution.*

*Do not use detergents that could scratch the surface plates.  
(abrasives, harsh fabrics, etc.)*

*Do not use solvents or alkaline detergents or cleaners with ammonia  
(ammonium hydroxide).*

*Do not remove the impurities from the surface of the razor blades or other sharp items.*

*Do not clean cabine, when the polycarbonate plates are heated by the sun.*

*Do not use the squeegee, it could be scratched surface plates.*





*Do not clean the water current strength greater than 50 bar (WAP)*

*The manufacturer is not responsible for scratching the surface in case of failure to comply with the above instructions.*

*All bolted connections of cab must be by user at regular intervals checked and tightened.*

**TOOLS NEEDED**  
**Not included**

		
<b>Ratchet handle</b>	<b>Socket beg 19 mm (0,75 in)</b>	<b>Socket beg 13 mm (0,51 in)</b>
		
<b>Socket beg 10 mm (0,39 in)</b>	<b>Hex key 5 mm and 6 mm</b>	<b>Metric wrench 19mm</b>
		
<b>Metric wrench 13mm</b>	<b>Metric wrench 10mm</b>	<b>Utility knife</b>

		
<p><b>Drill <math>\phi</math> 8mm</b> <b>(0,31-0,33 in)</b></p>	<p><b>Drill <math>\phi</math> 12mm</b> <b>(0,5 in)</b></p>	<p><b>Drill <math>\phi</math> 20-23mm</b> <b>(0,79-0,91 in)</b></p>
		
<p><b>Drill <math>\phi</math> 25 mm</b> <b>(1 in)</b></p>	<p><b>Isolating tape</b> <b>clear OR black</b></p>	

CAB PREVIEW

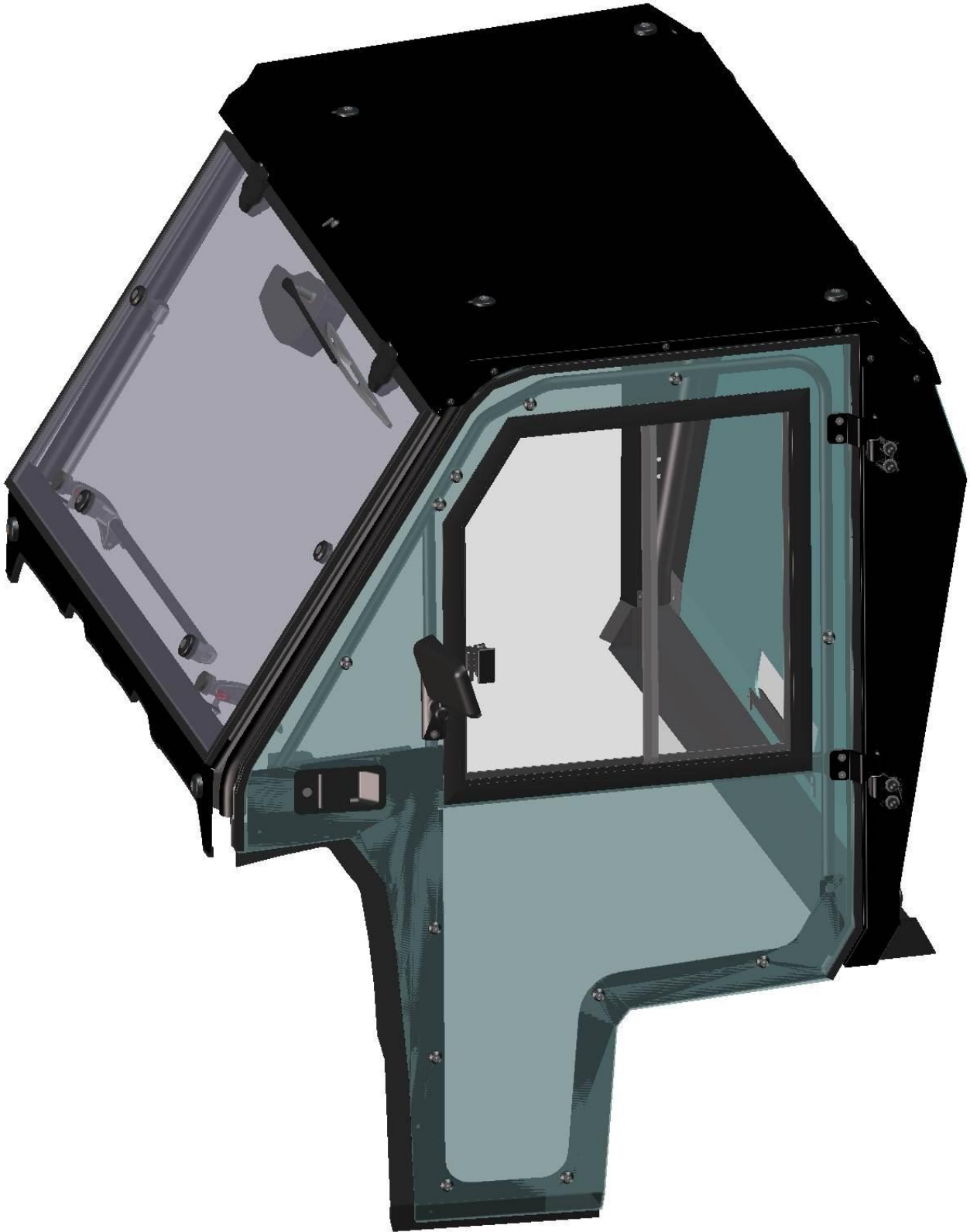

**PREPARATION FOR INSTALLATION:**

Uninstall the side safety networks assembly from both sides. (In red poligon)



View on to the left bottom corner.

Detail onto the safety networkks holder.  
(In red rectangle.)



**FRONT PANEL (1-part):**

Place the front bottom ledge onto the roller cage and press that on to the dashboard.

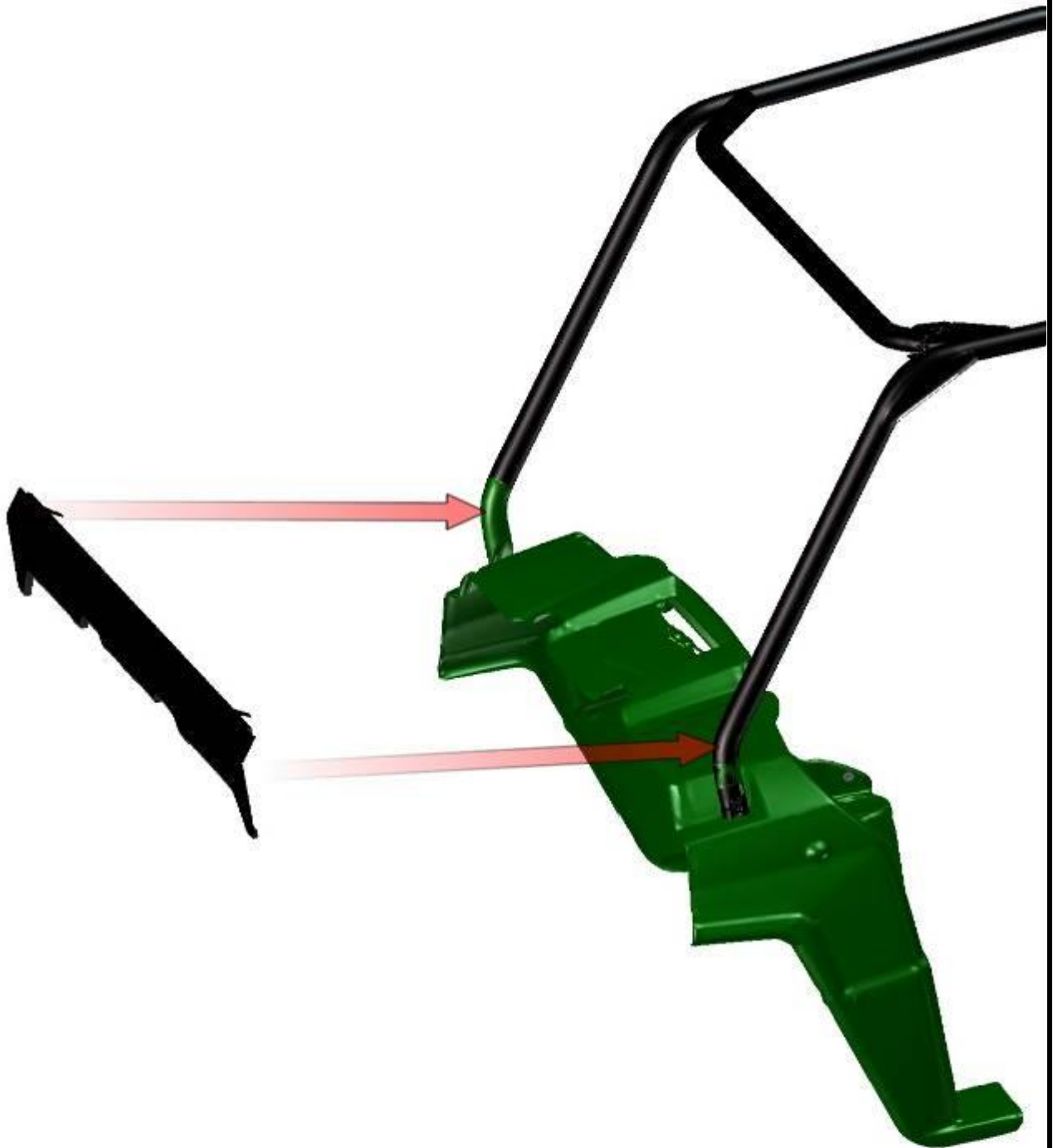



Install the door stop assembly (pin, hook, washer and nut) with door stop holder(1,2). Place the door stop holder onto the front ledge right holder (3). Place the gas spring holder onto the front ledge holder (4). Fix the front ledge holder with the door stop holder and with gas spring holder by nuts, wahers and nut cover (5).

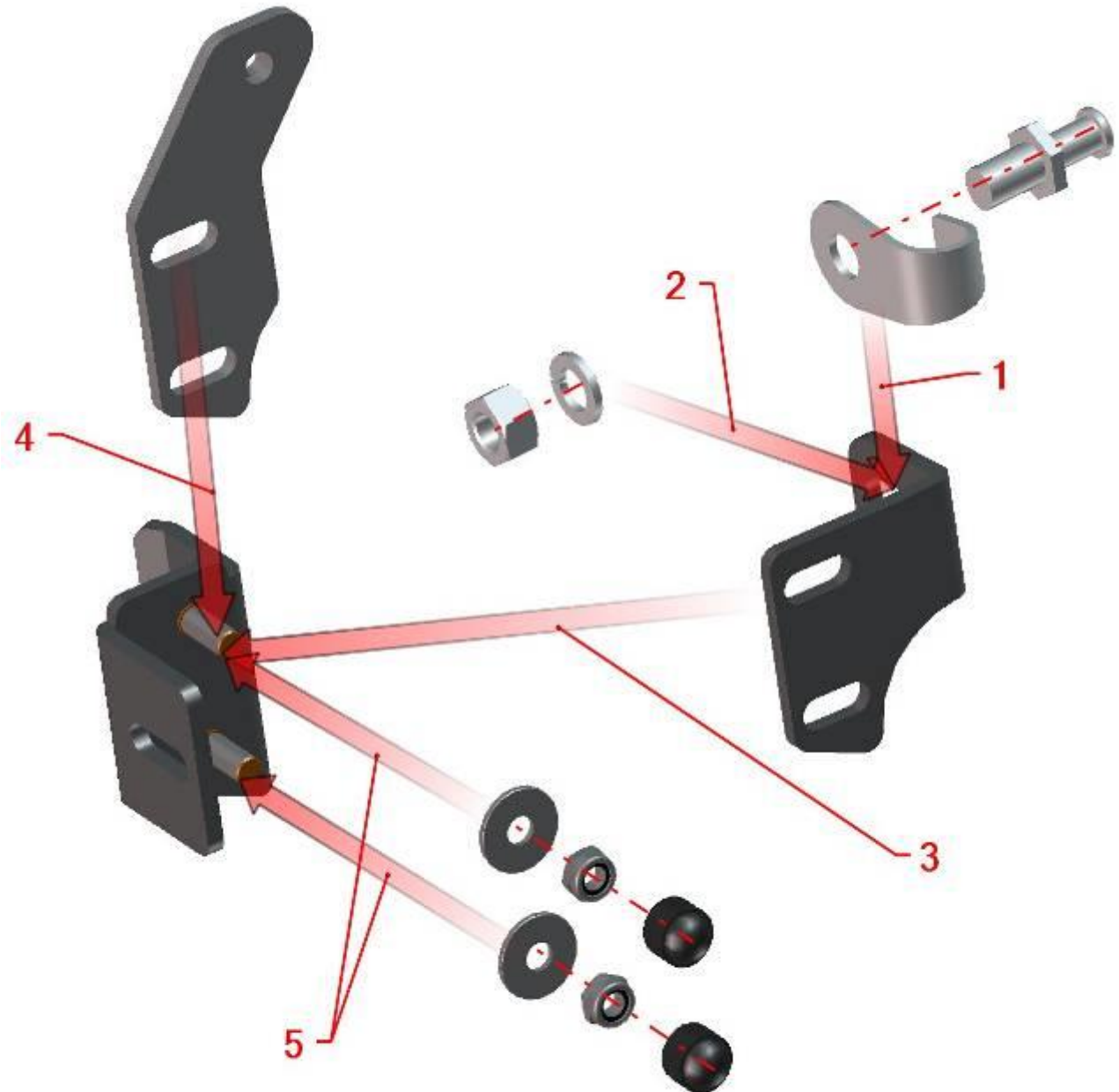

Repeat the steps from previous page with the front ledge left holder.

Place the front bottom ledge holders on both sides.

Fix holders with the ledge to the roller cage by screws, washers, nuts and nut covers.

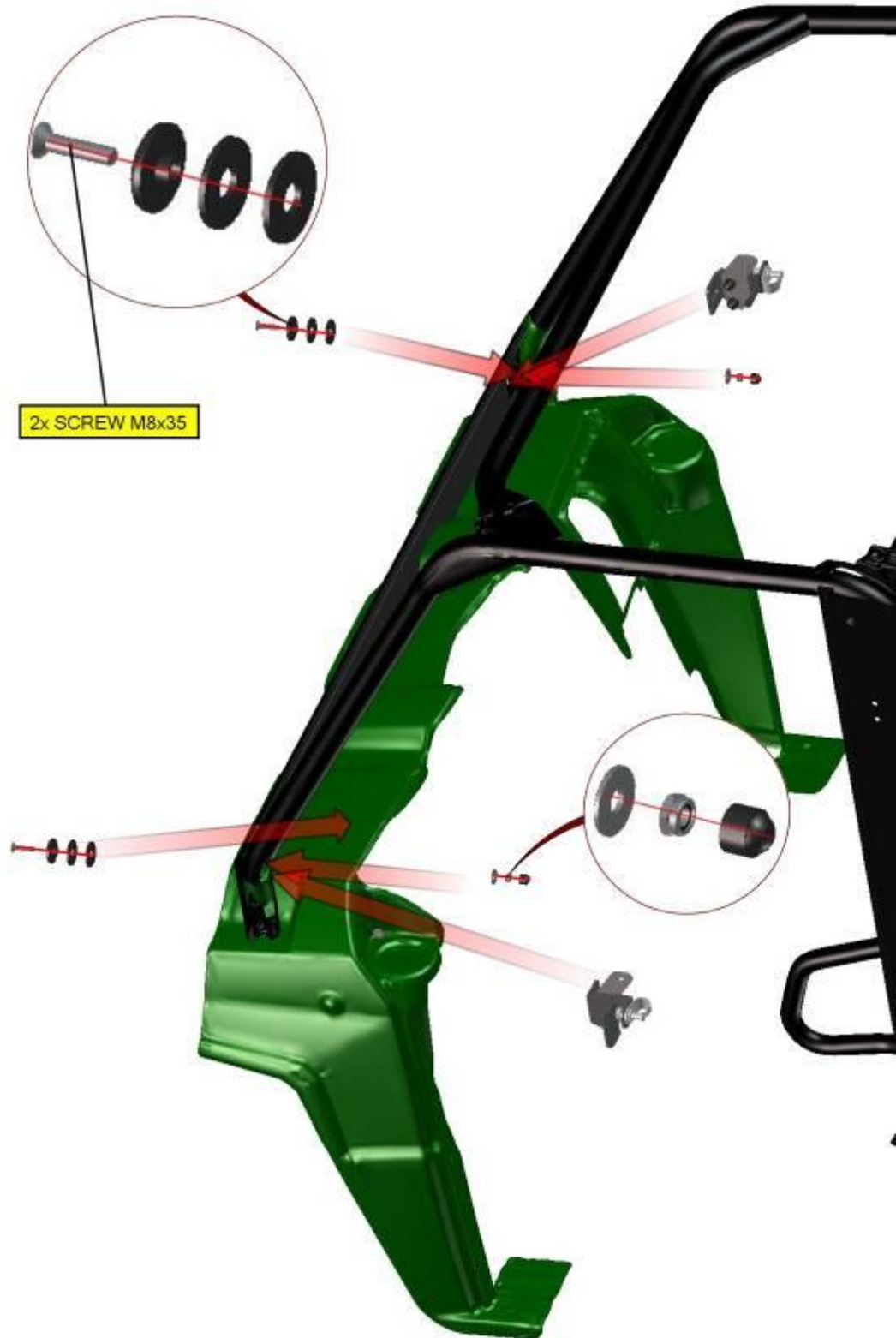

Cut the tightening straps in the hinges and place the hinge washers onto the front window hinges and place the upper front ledge onto the hinge washers.

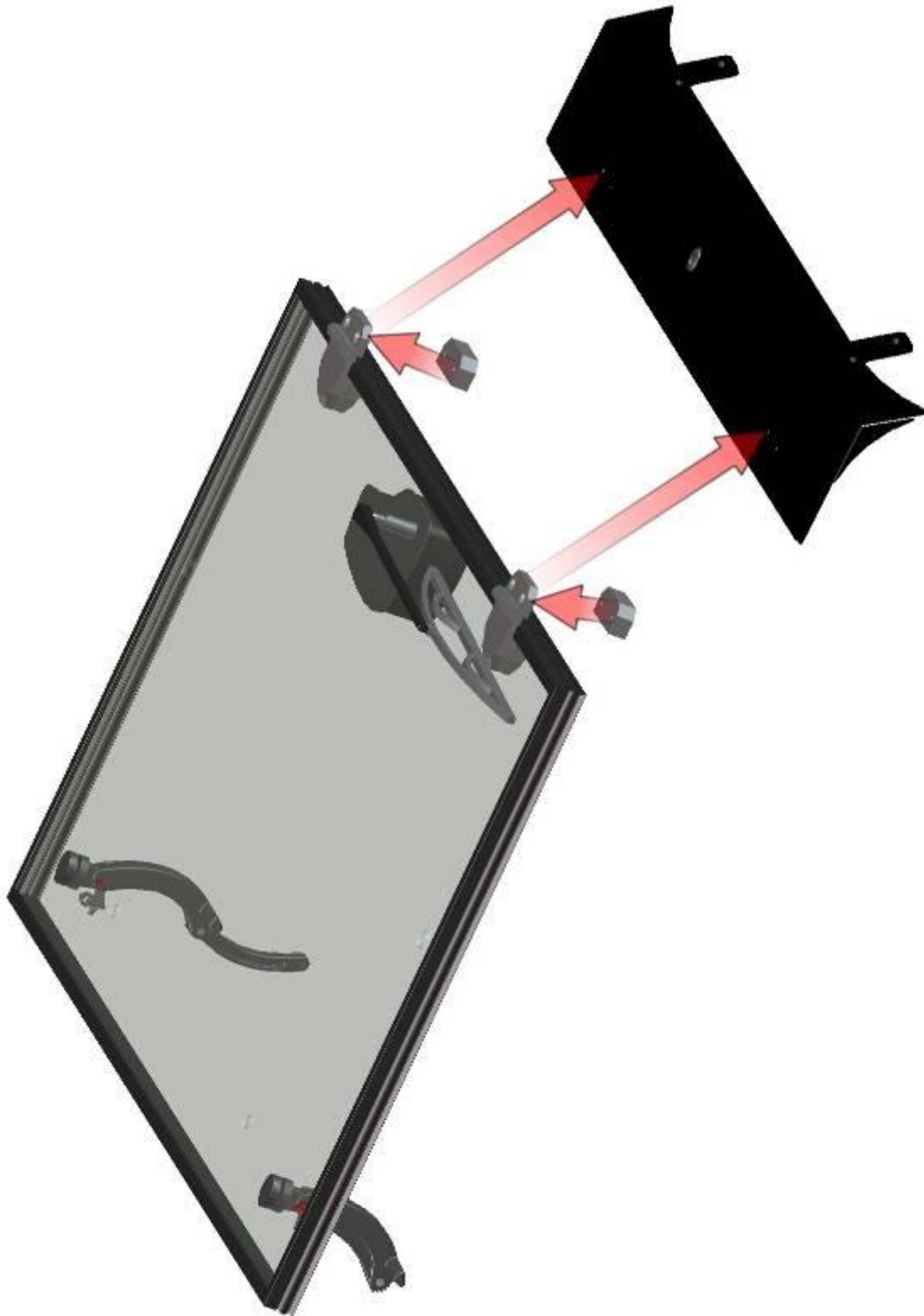

Fix the hinges with the front upper lege by screws, washers, nuts and nut covers.

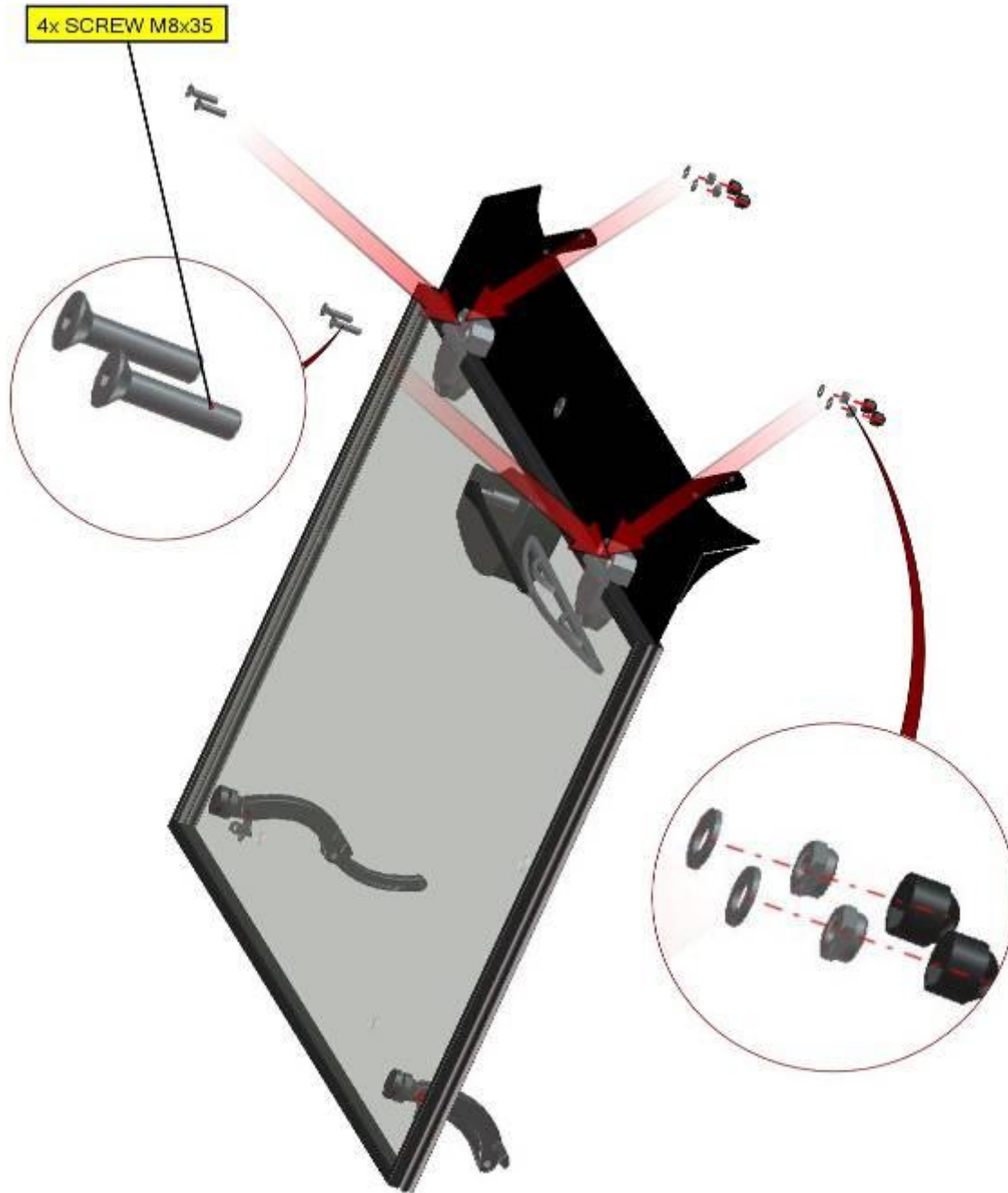

**ROOF PANEL (1-part):**

Place the rear roof holders onto the roof part of the UTV's roller cage.

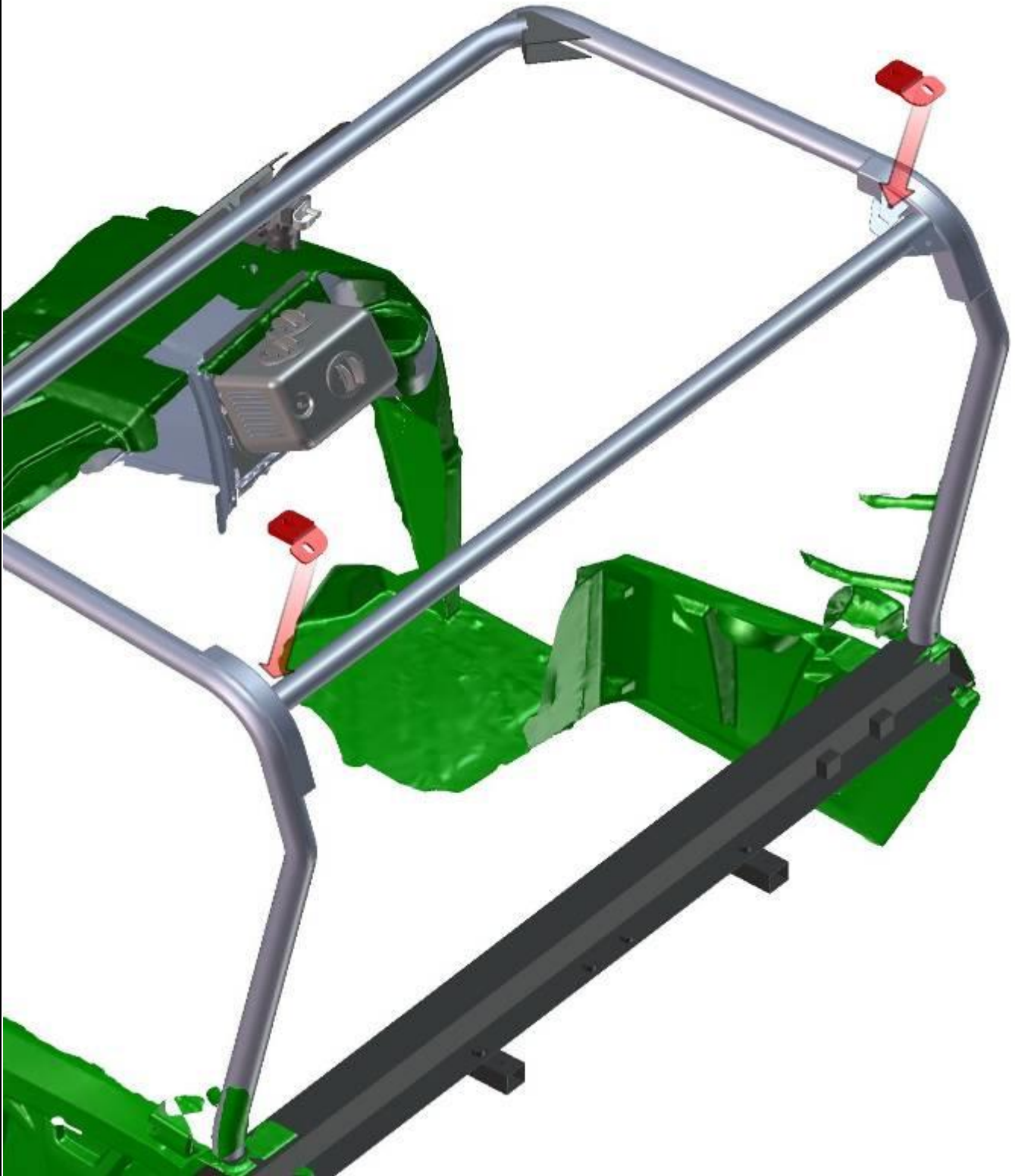

13

Fix the rear roof holders with roller cage by screws, washers, nut and nut covers.

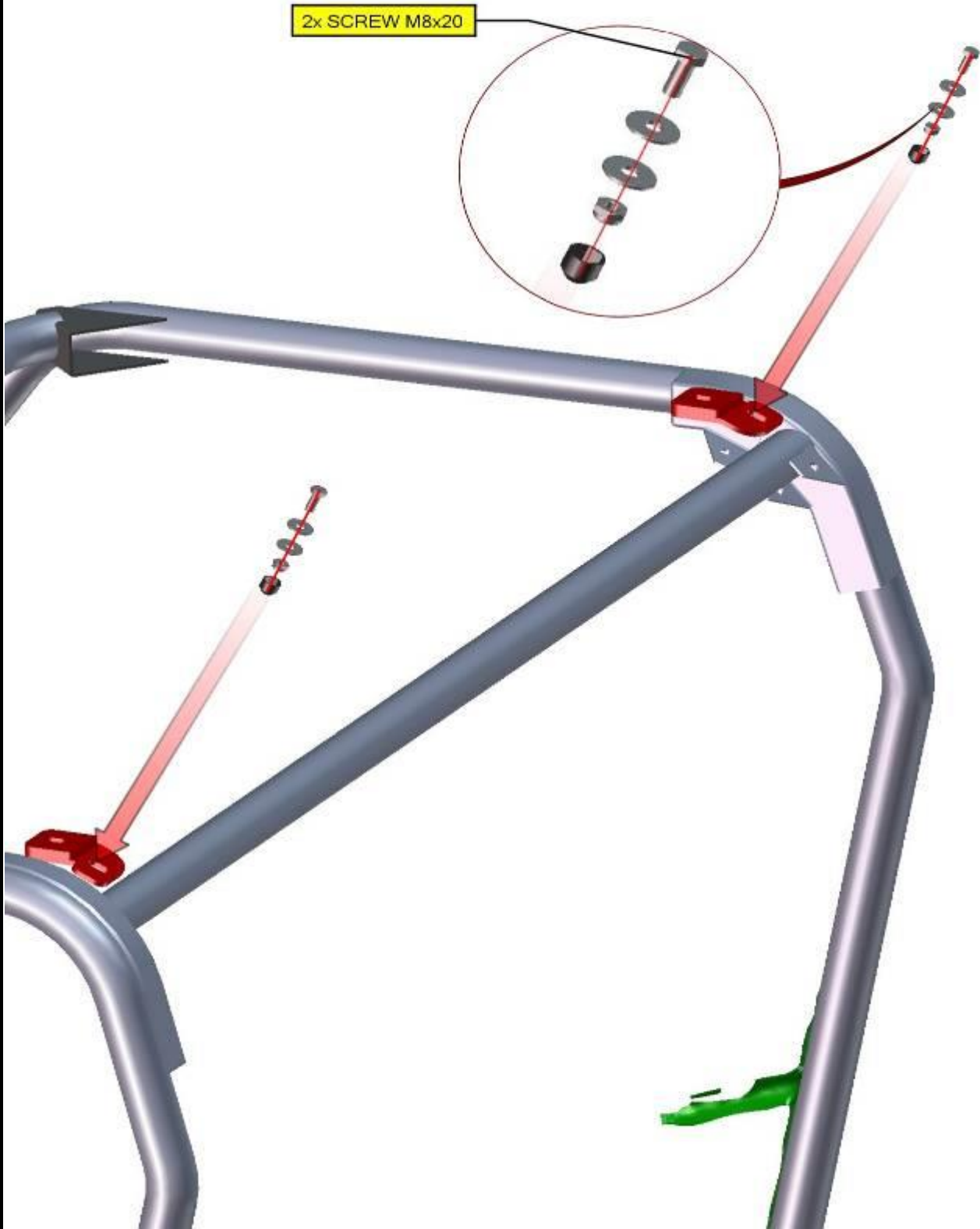

Detail view on the rear roof holder.



**FRONT PANEL (2-part):**

Place the front window and the front upper ledge onto the roller cage.

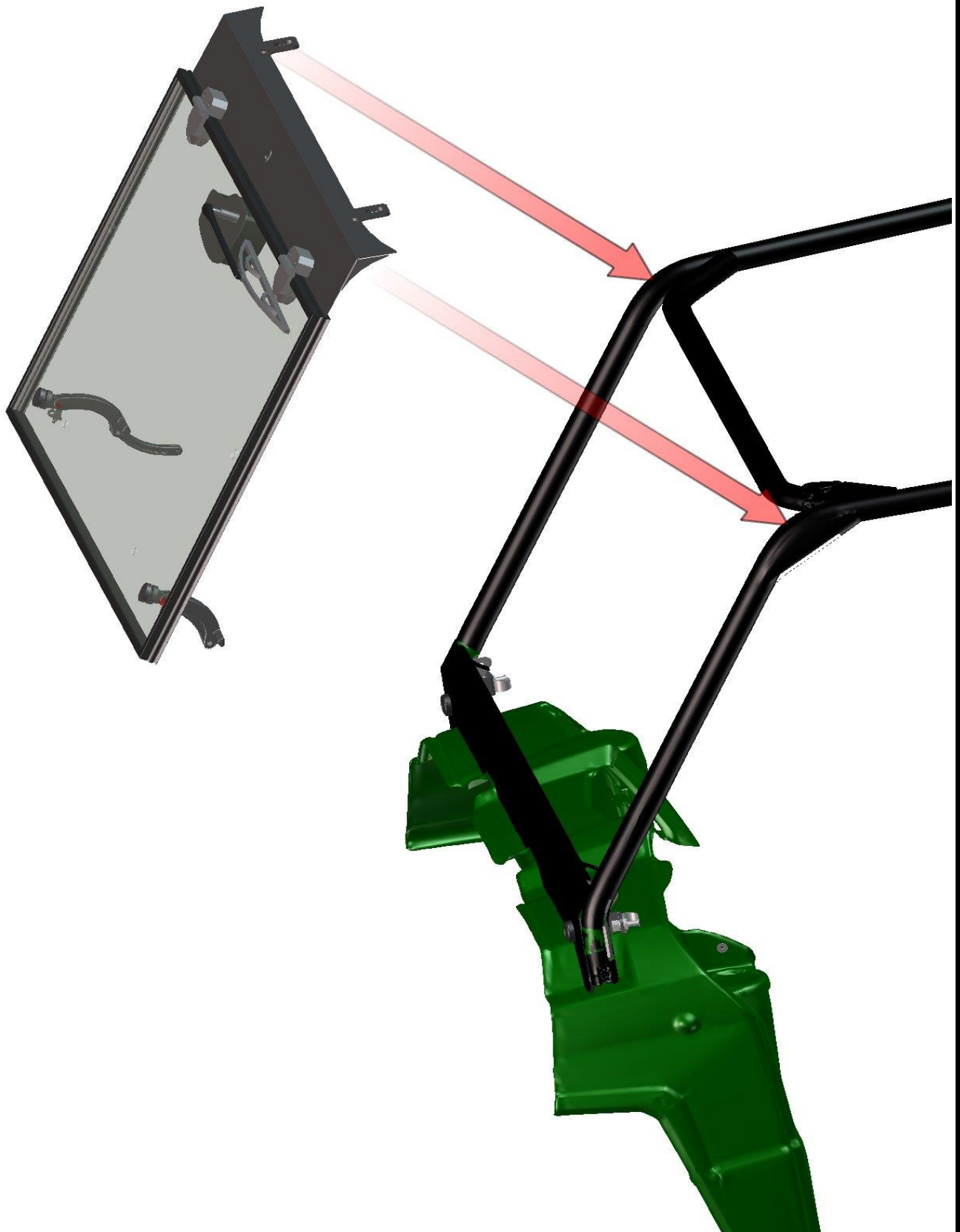



**ROOF PANEL (2-part):**

Place the roof panel onto the UTV's roller cage.

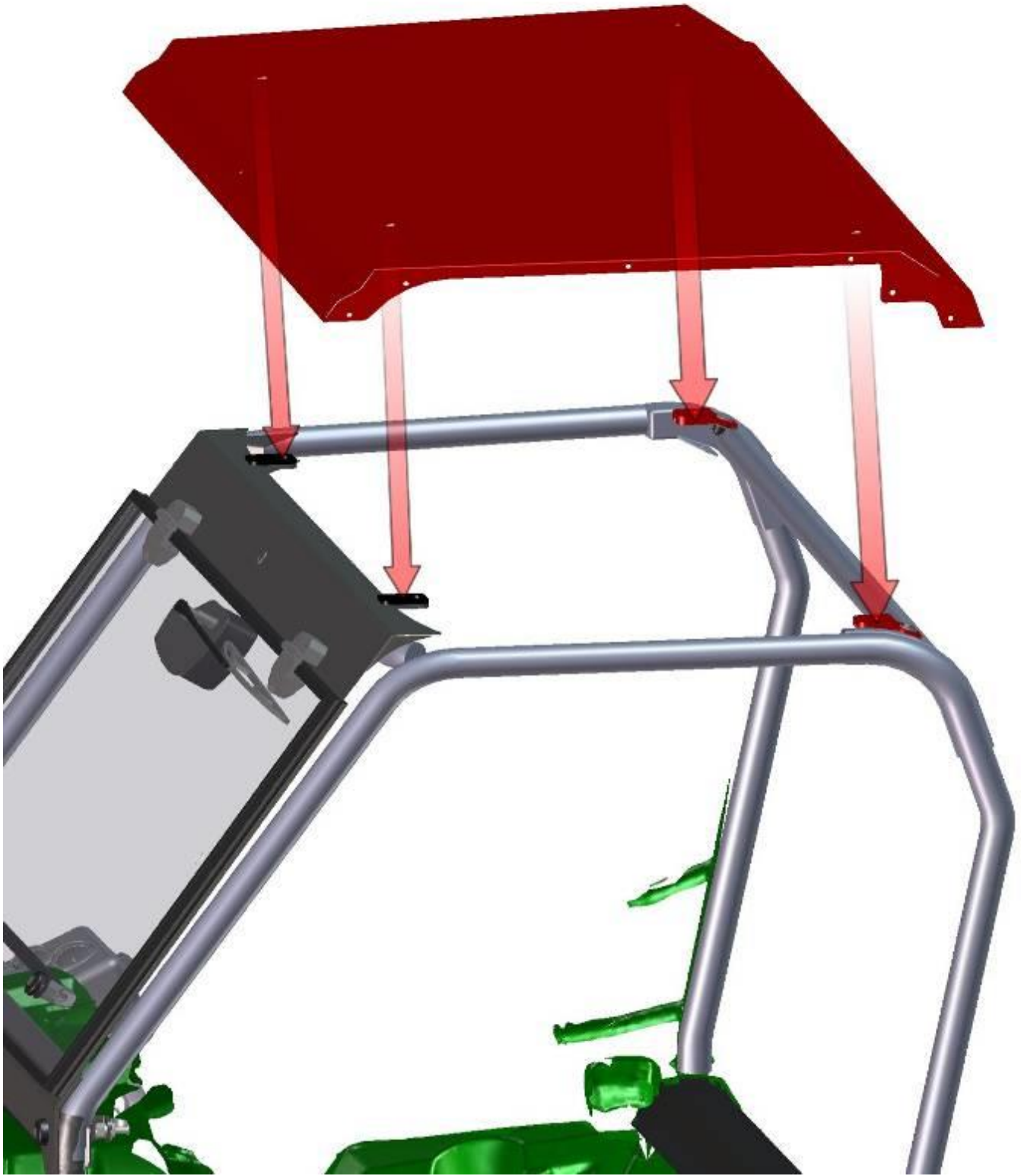

Hold the front window on position and place the front ledge holder onto the front ledge.



Fix the roof panel with the roof holders to UTV's roller cage by screws, washers, nuts and nut covers.  
Do not tight these screws hard yet!

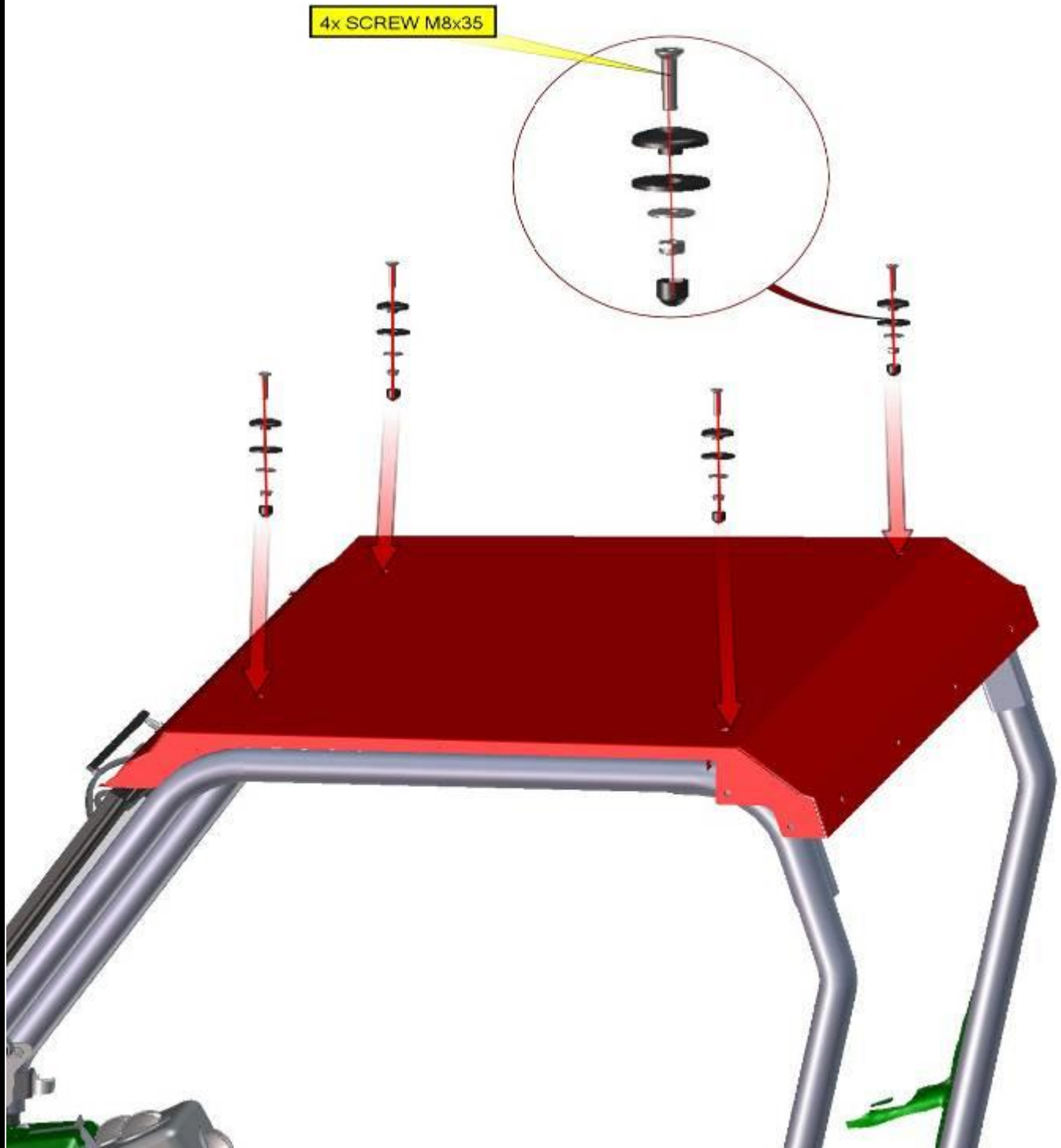

Detail views onto the roof holders.



**FRONT PANEL (3-part):**

Fix the glass adjustable holders holder with the front bottom ledge by screw, washer and nut on both sides.  
**DON'T TIGHT THESE SCREWS NOW**

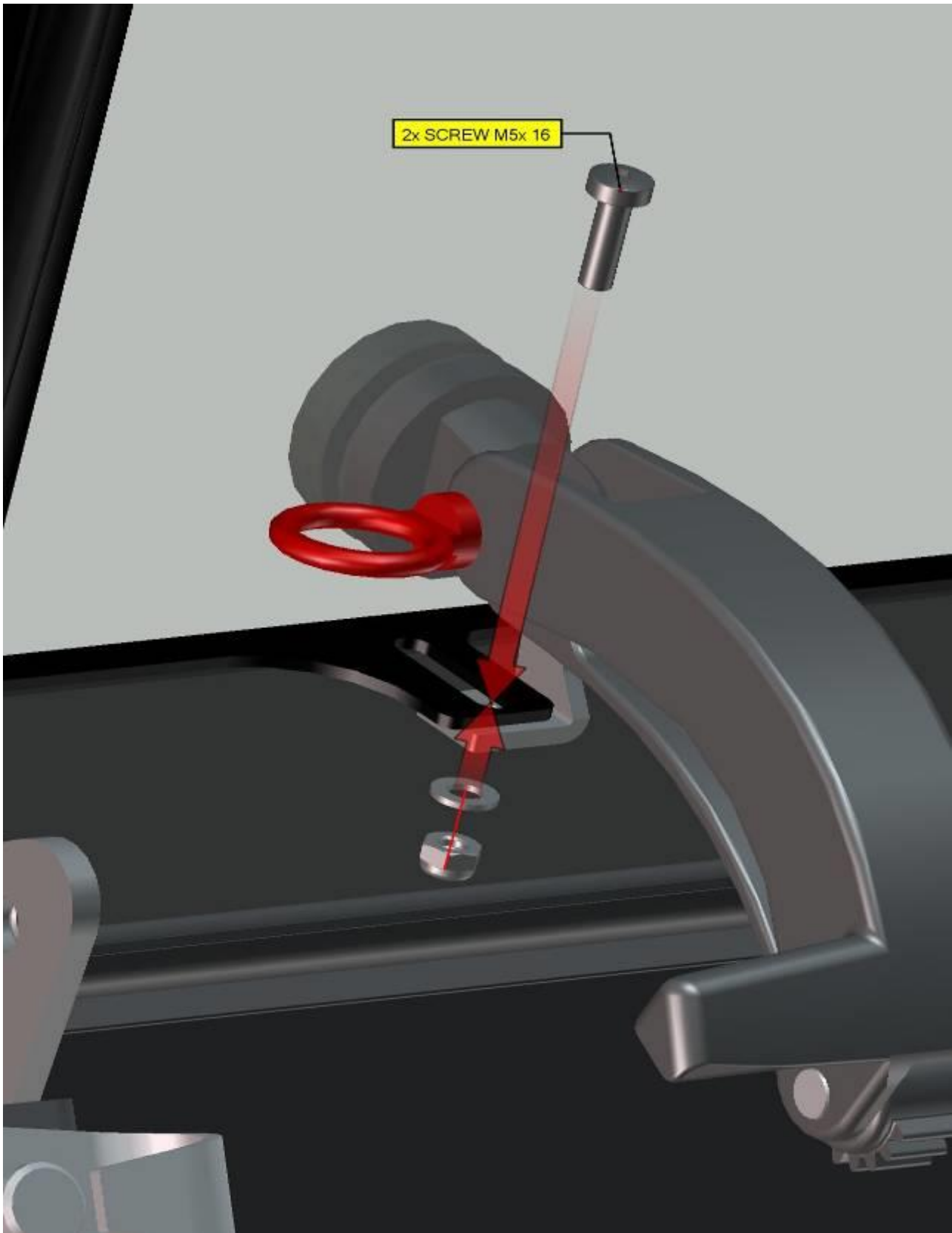

21

Open and close the front window, adjust the holder to best position and tighten screws from previous page hard. By adjusting glass lock holders to you can change press between the front glass seal and the bottom ledge. If you need more pressure you can uninstall glass lock holders and change left with right and rotate around vertical axis.

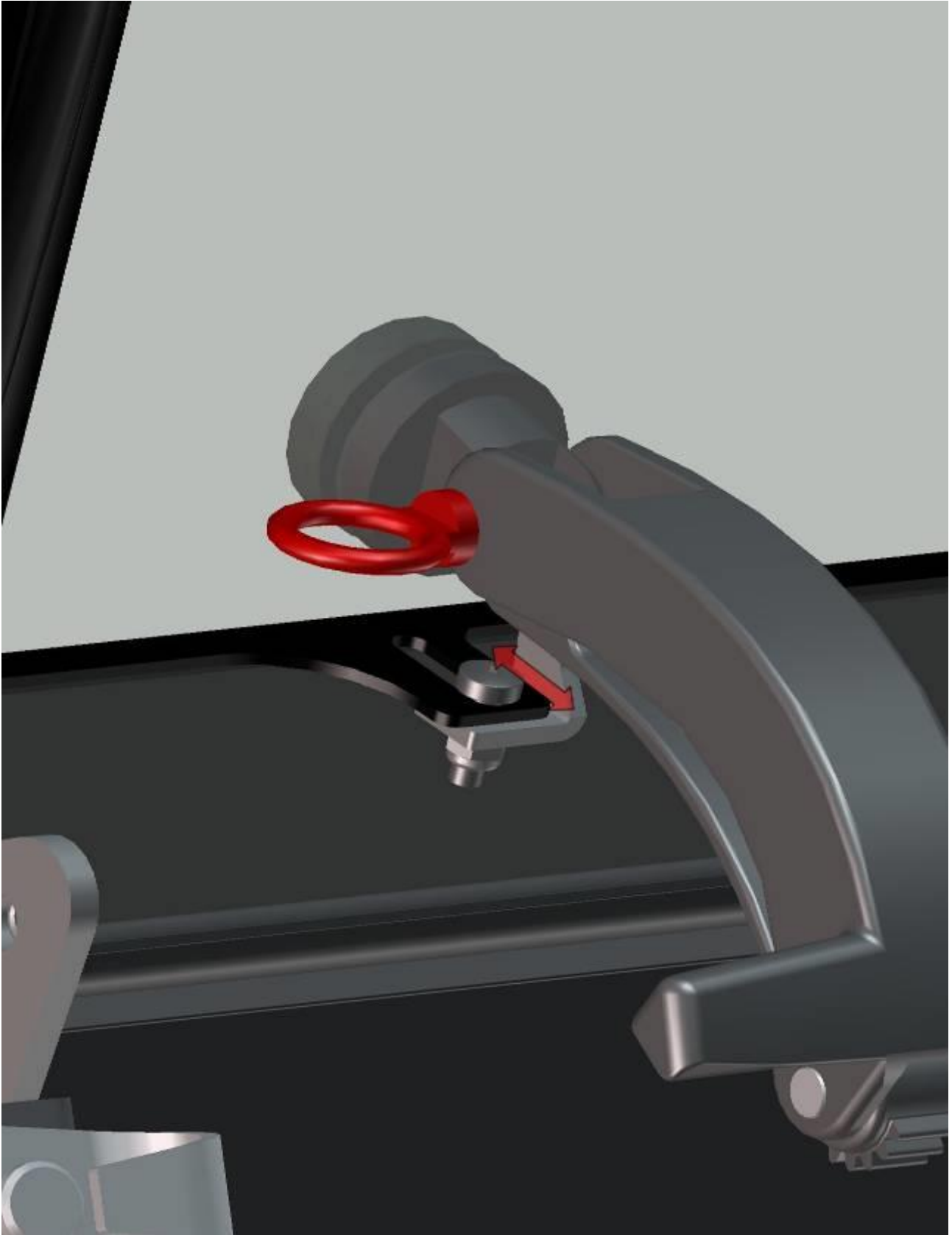

Place the handle holders onto the handle bar and place the handle onto the front window.  
Fix the handle holders with the window by screws, washers nuts and nut covers.

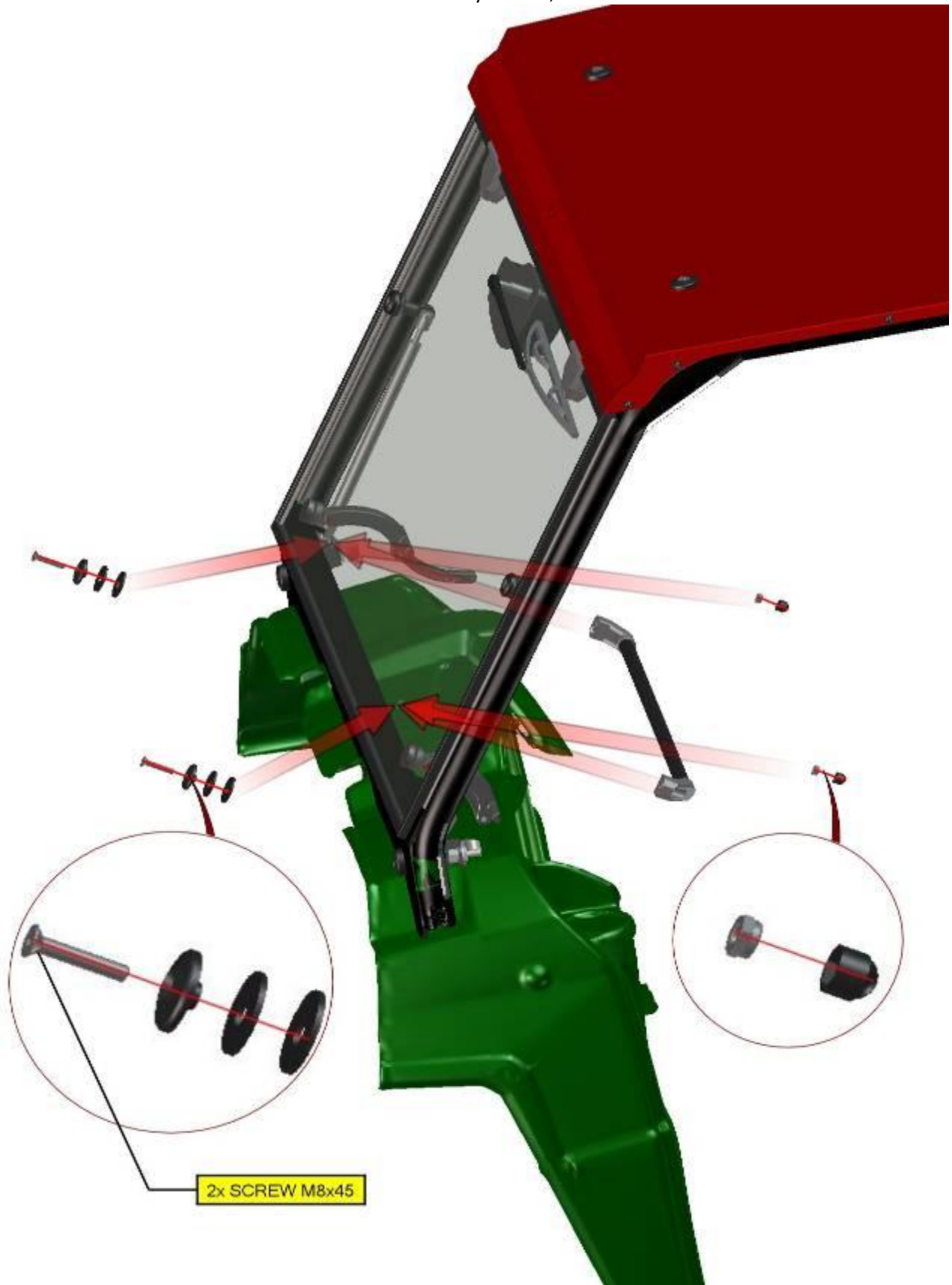

Place the gas spring holder onto the window and fix these by screw and washer on both sides.  
DON'T TIGHT THESE SCREWS NOW

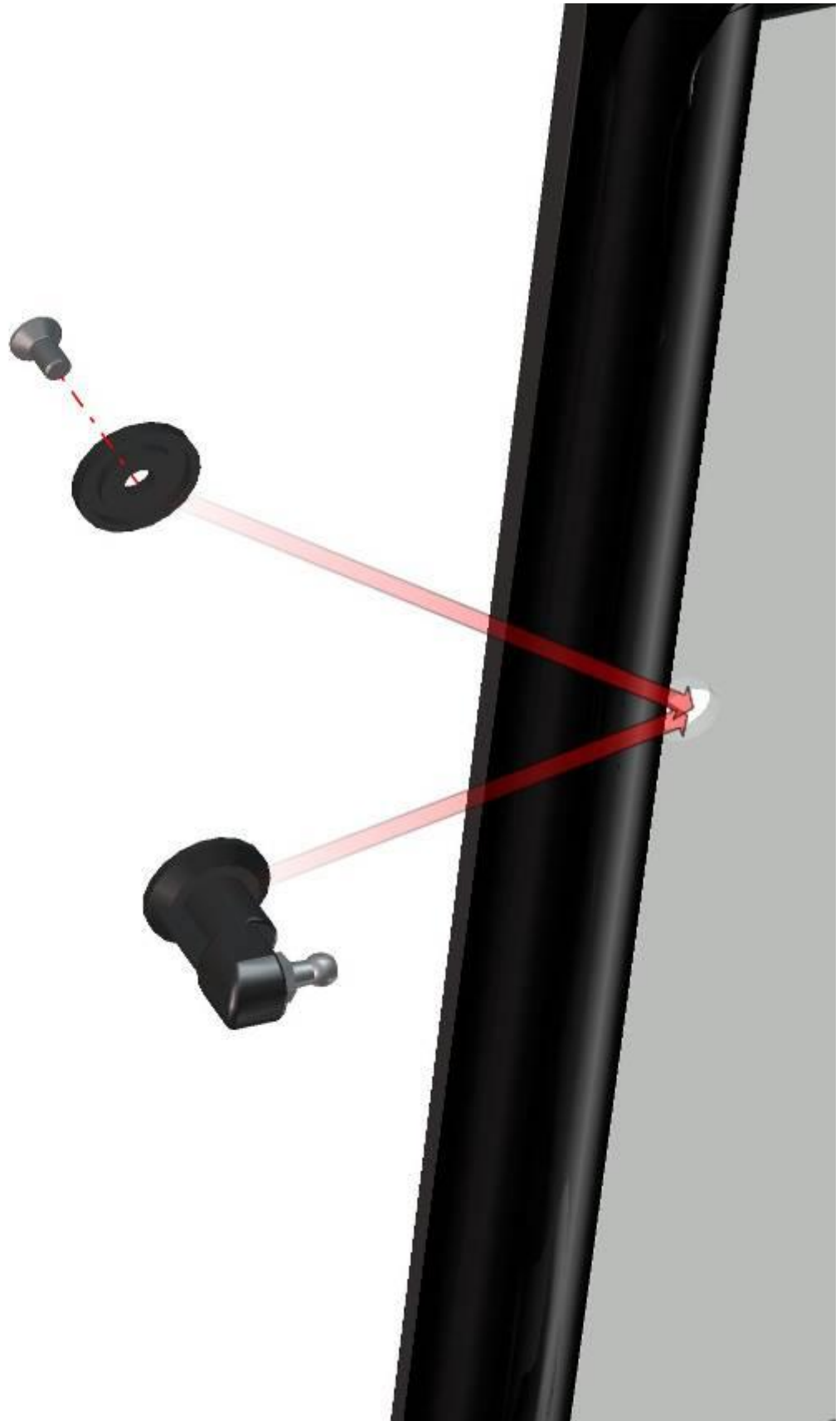



Connect the gas spring with the gas spring holder.

*IT IS IMPORTANT TO INSTALL GAS SPRING IN SAME ORIENTATION LIKE IN PICTURE*



25

FOR ALL TECHNICAL QUESTIONS, PLEASE CALL  
DFK AMERICA INC.  
(630) 324-6793

Fix the gas spring pin with the gas spring holder metal.

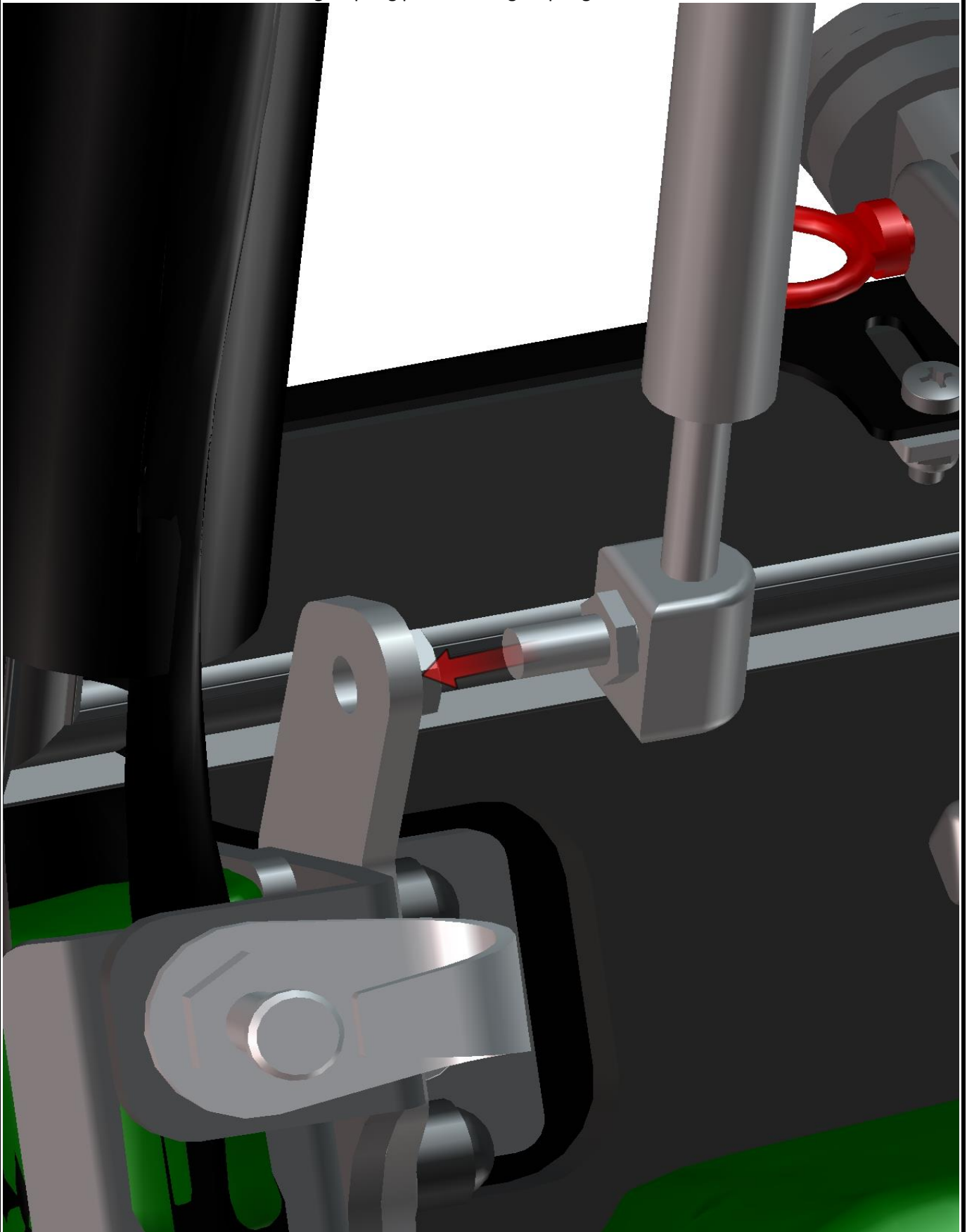

Stick the seal (red line) onto the roller cage on both sides



Detail view on the upper right corner of the front window.



Detail view on the bottom right corner of the front window.



FOR ALL TECHNICAL QUESTIONS, PLEASE CALL  
DFK AMERICA INC.  
(630) 324-6793

**METAL DOOR BASES (LEFT + RIGHT):**

Uninstall the upper outer original screws from the rear safe cross on both sides.



Uninstall the bottom original screws from the rear UTV's roller cage on both sides (in red ellipse).



FOR ALL TECHNICAL QUESTIONS, PLEASE CALL  
DFK AMERICA INC.  
(630) 324-6793

Place the metal door bases onto the UTV's roller cage from both sides.



Fix the roof with the metal door bases by screws on both sides.

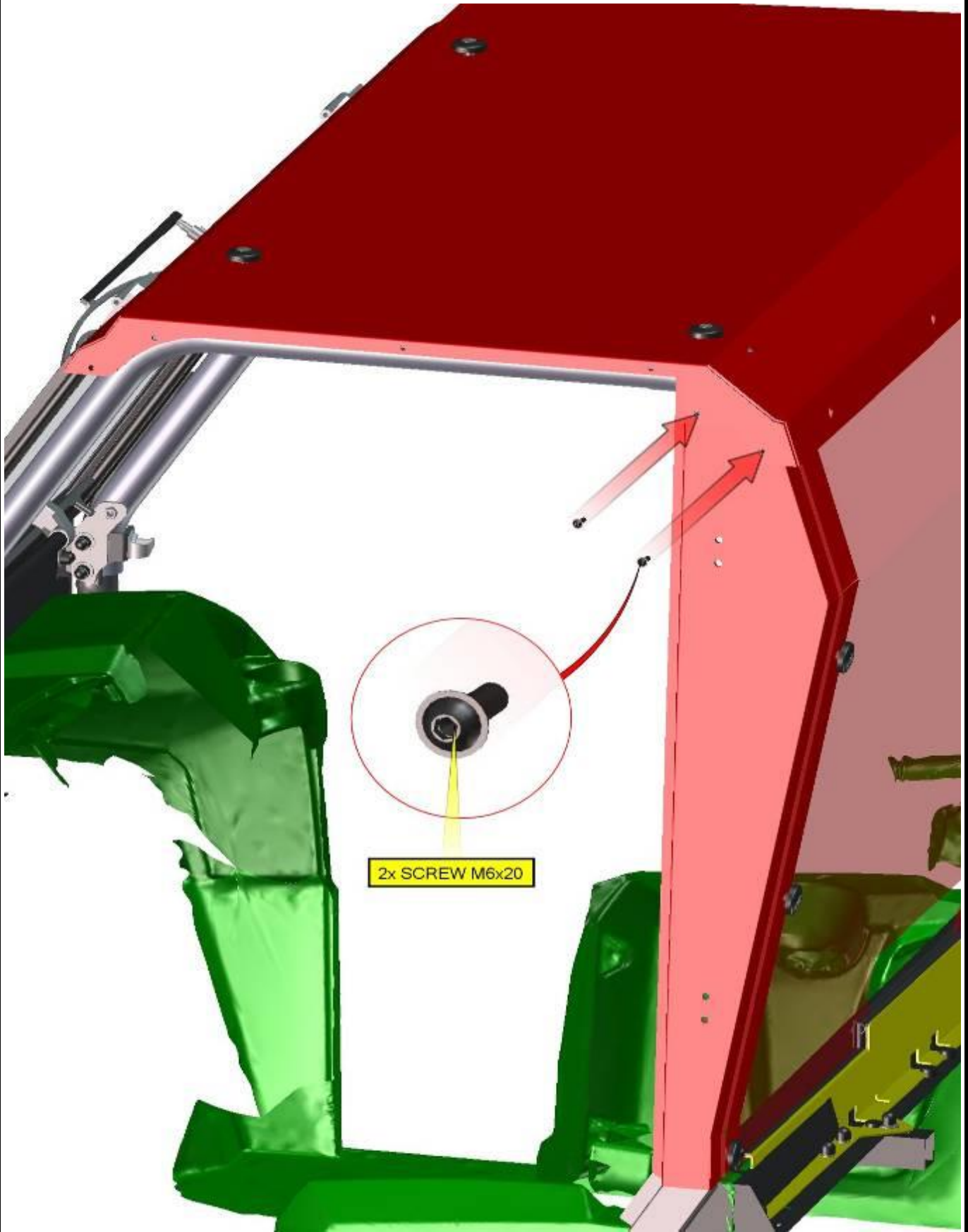

FOR ALL TECHNICAL QUESTIONS, PLEASE CALL  
DFK AMERICA INC.  
(630) 324-6793

**REAR PANEL:**

Stick seal onto the rear central part of the roller cage.





Pull out the safeguard films from rear polycarbonate window.  
Place the rear polycarbonate window onto the metal door bases

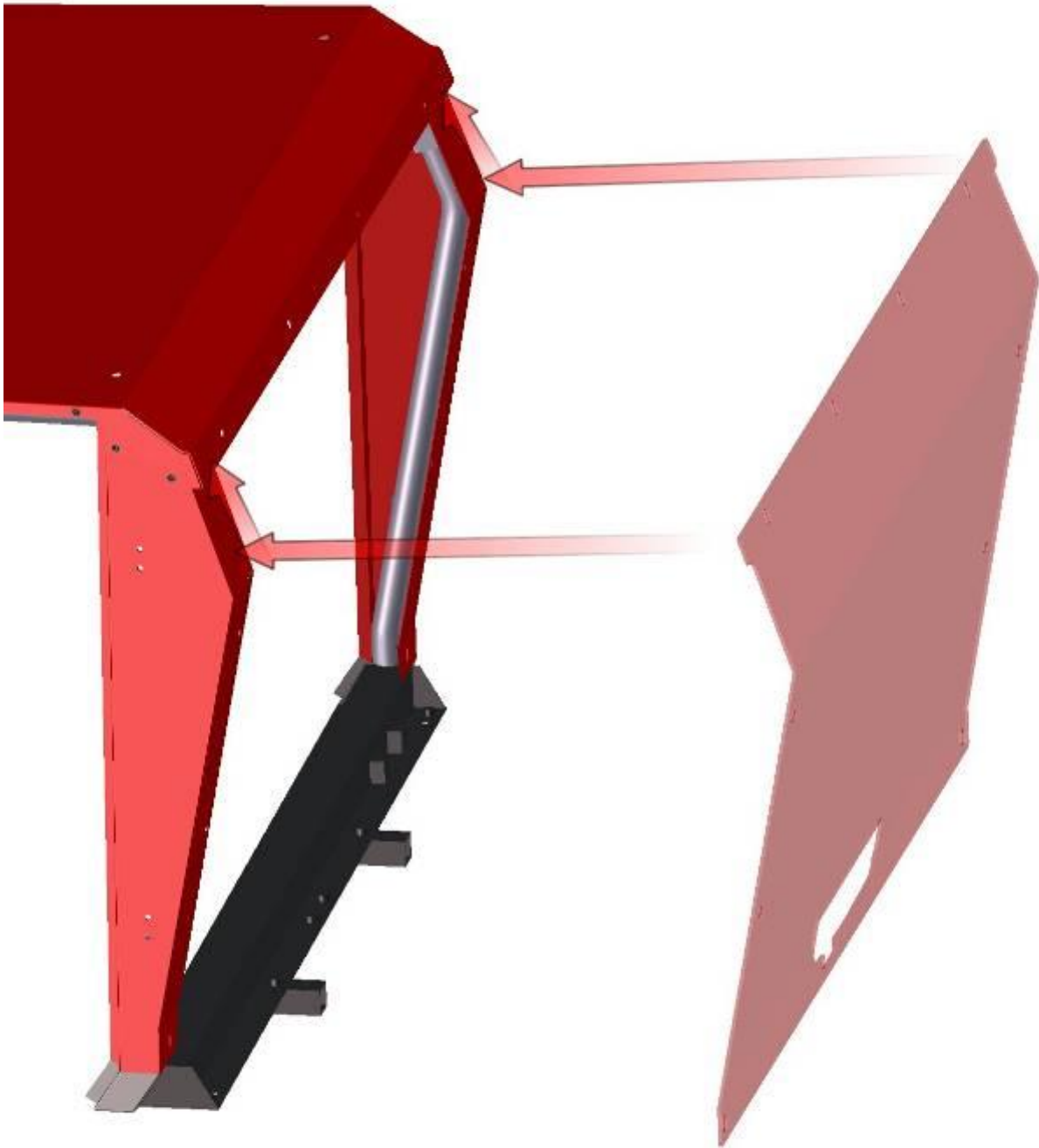

Fix the polycarbonate rear window with the door bases to roller cage by screws, washers, nuts and nut covers.

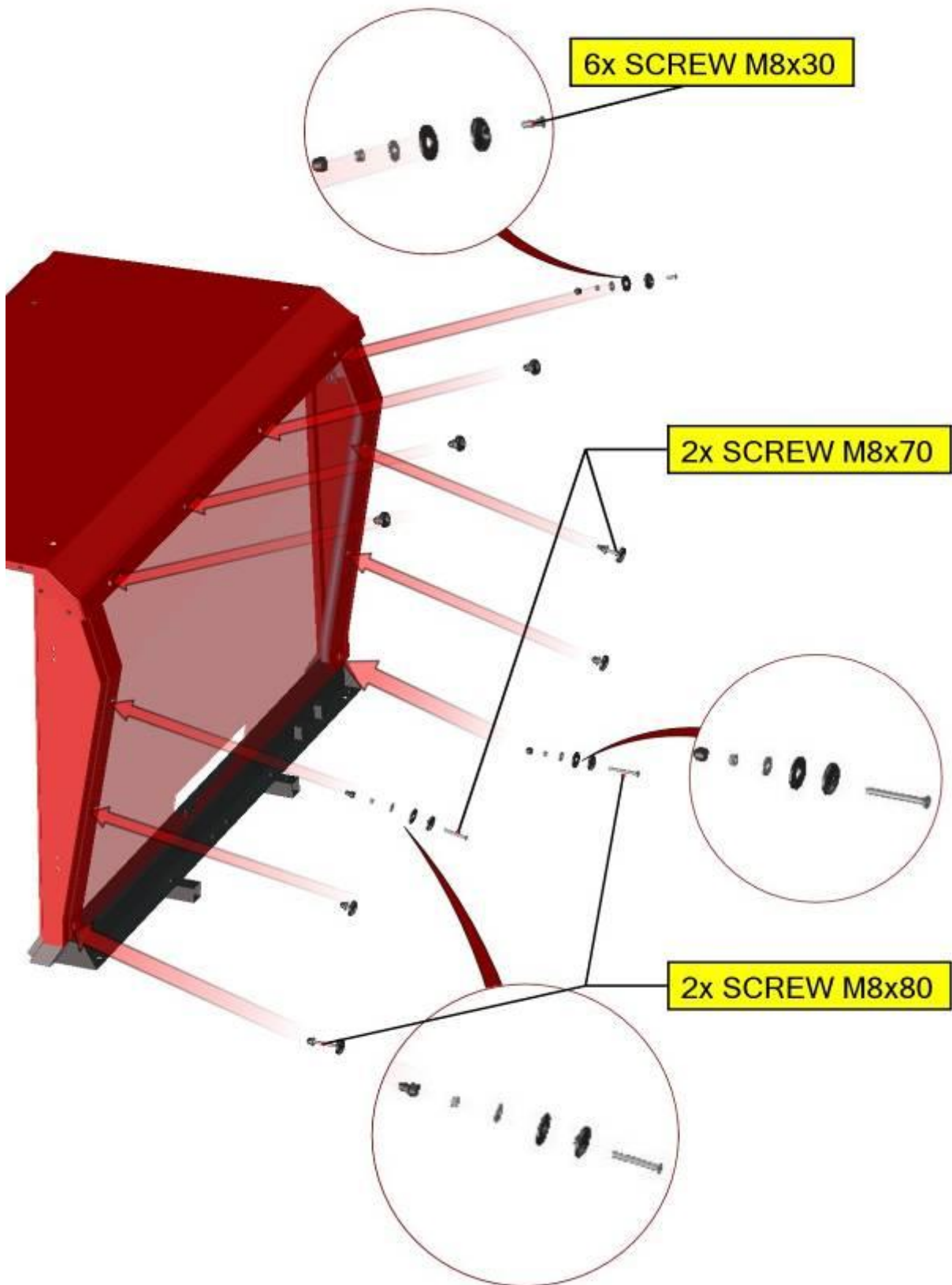

Rear panel after fixing – external view:



Place the rear bottom metal ledge onto the correct position.

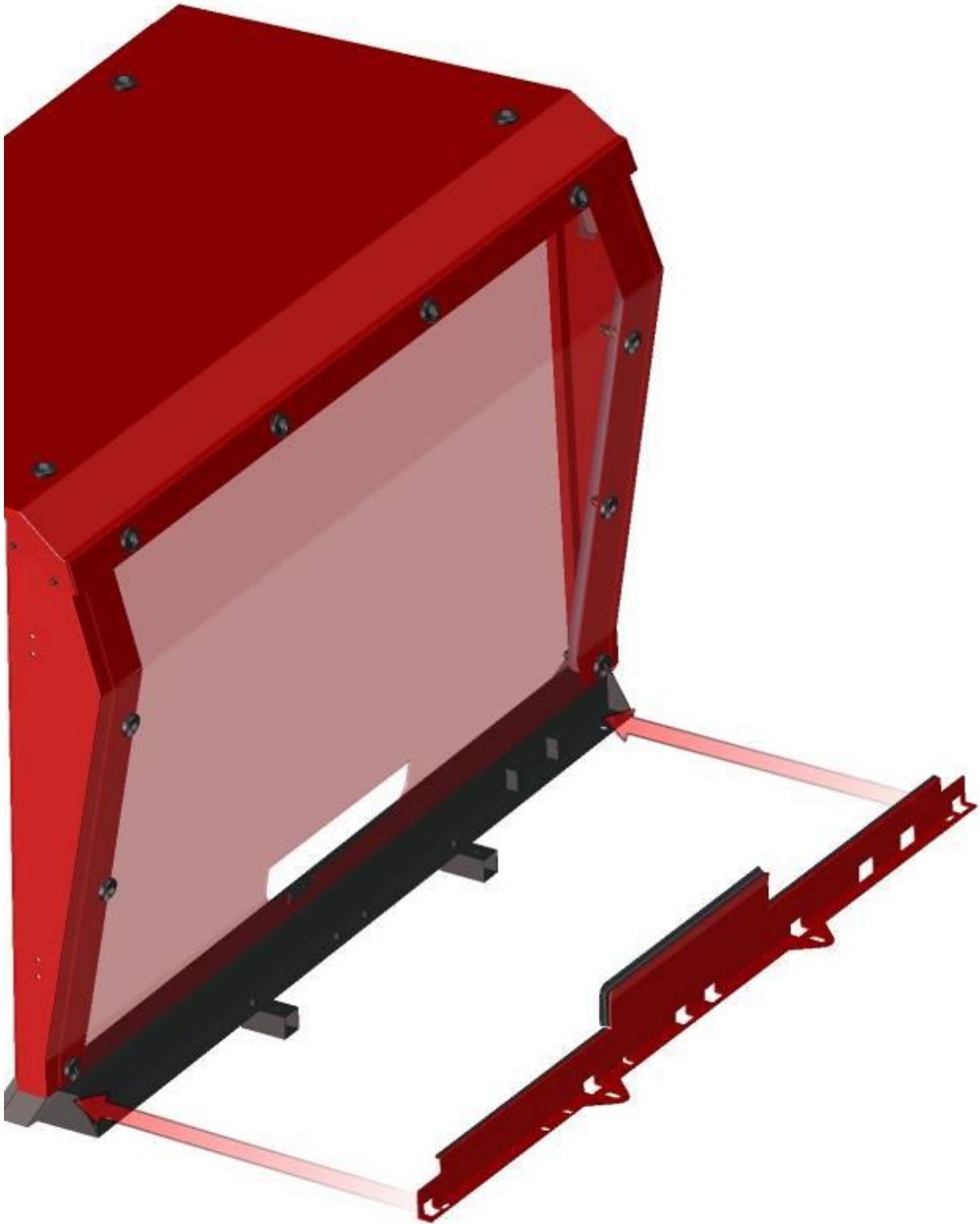

Fix the rear bottom ledge with the UTV's bottom ledge.

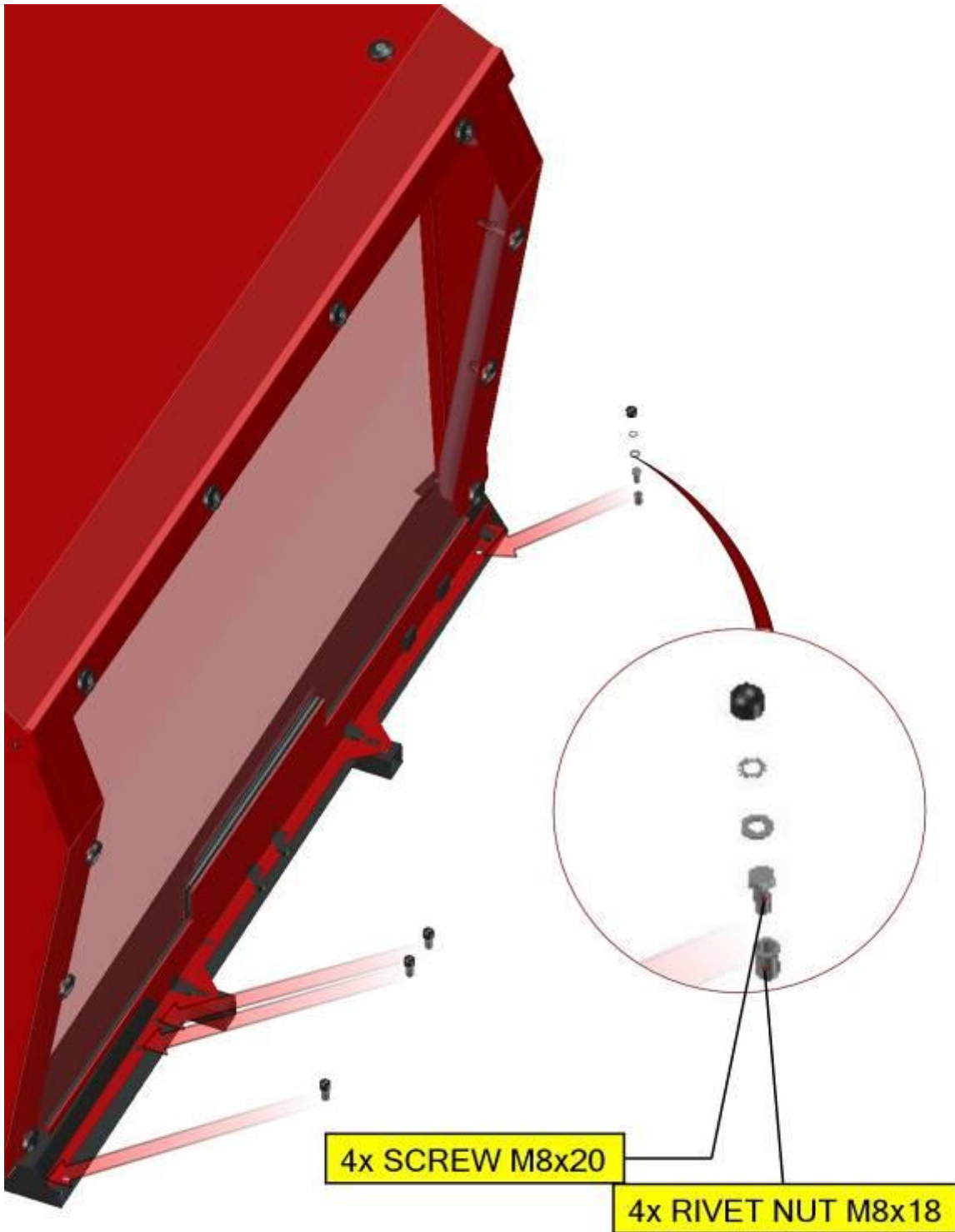

**DOOR LEFT:**

***INSTALLATION OF THE RIGHT DOOR IS IDENTICAL WITH THE INSTALLATION OF THE LEFT DOOR.***

Place the hinges onto the metal door base.



Fix the hinges with the metal door base by screws, washers, nut and nut covers.

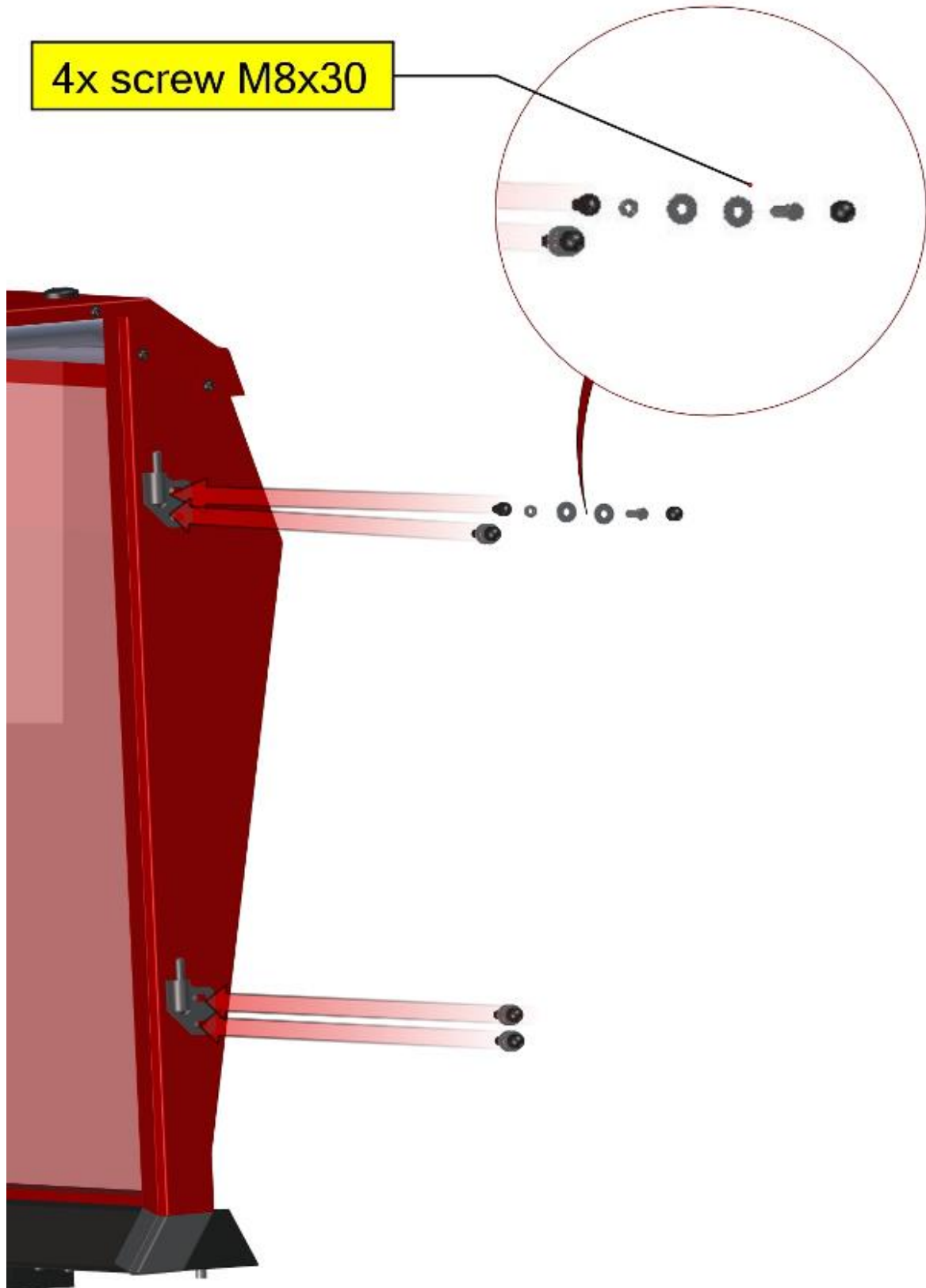

Detail view on fixed hinges from outside and from inside.





You have to lubricate the hinge's pins and place the door onto the hinges.

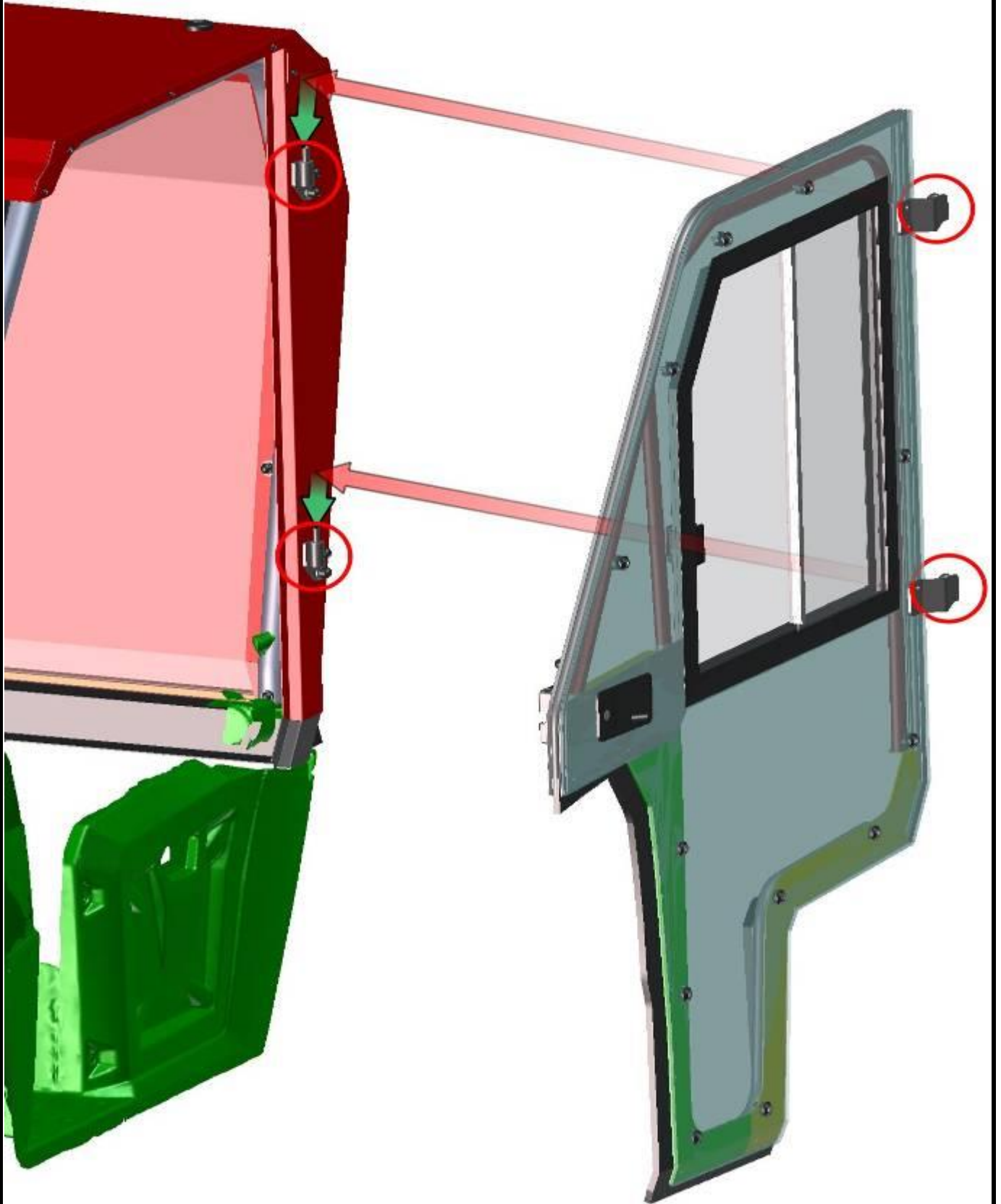

Adjust the door to make no gapes between the front roller cage, the UTV's body and the door sealing.  
Distance between the door, the roof and the door metal base (yellow line) has to be similar (from 4mm to 6mm).



Adjust the pin of door stop holder.

If you close the door slowly and holder has been adjusted correctly, you can hear clear 2 metallic click.

If you have problems with adjusting the pin holders, you can adjust the door hinges again to better position.

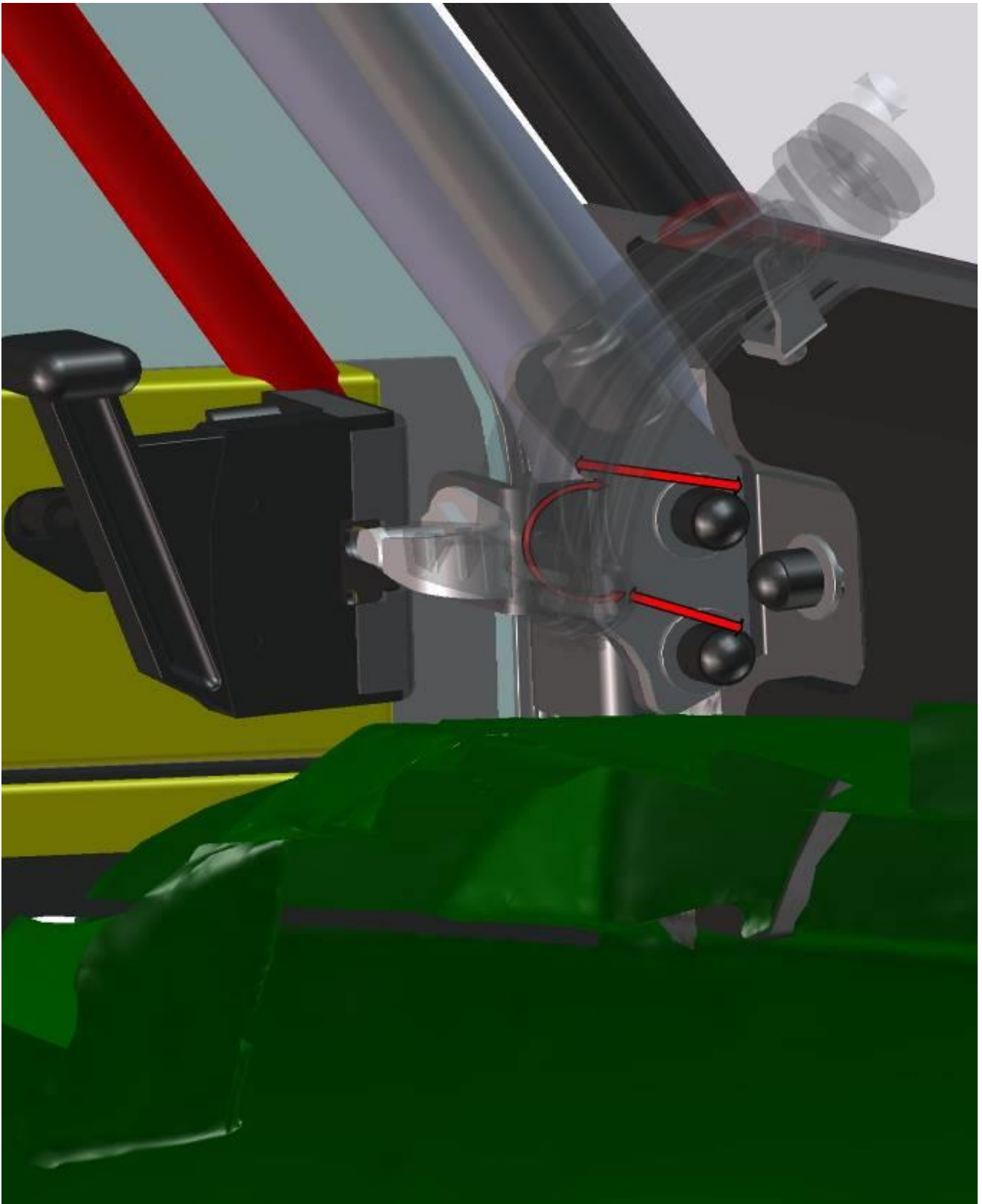

Now loosen the front bottom ledge nuts and adjust the door ledge epdm (red arrows).

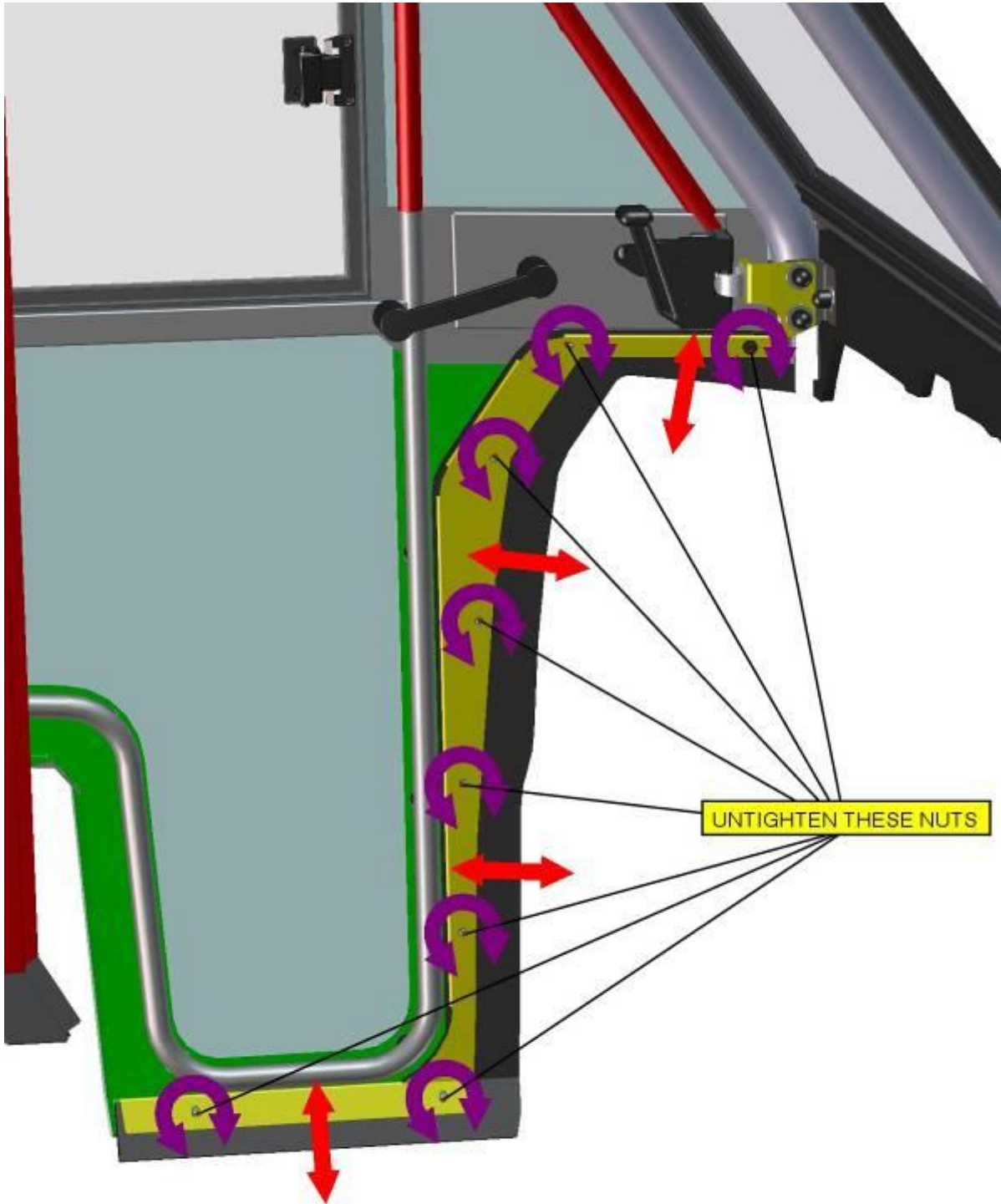

Take out the screws from the door (blue arrows) and place the rear mirror and the mirror washer onto the door panel (red arrows). Fix the mirror and the washer with the door by screws from previous step (blue arrows).

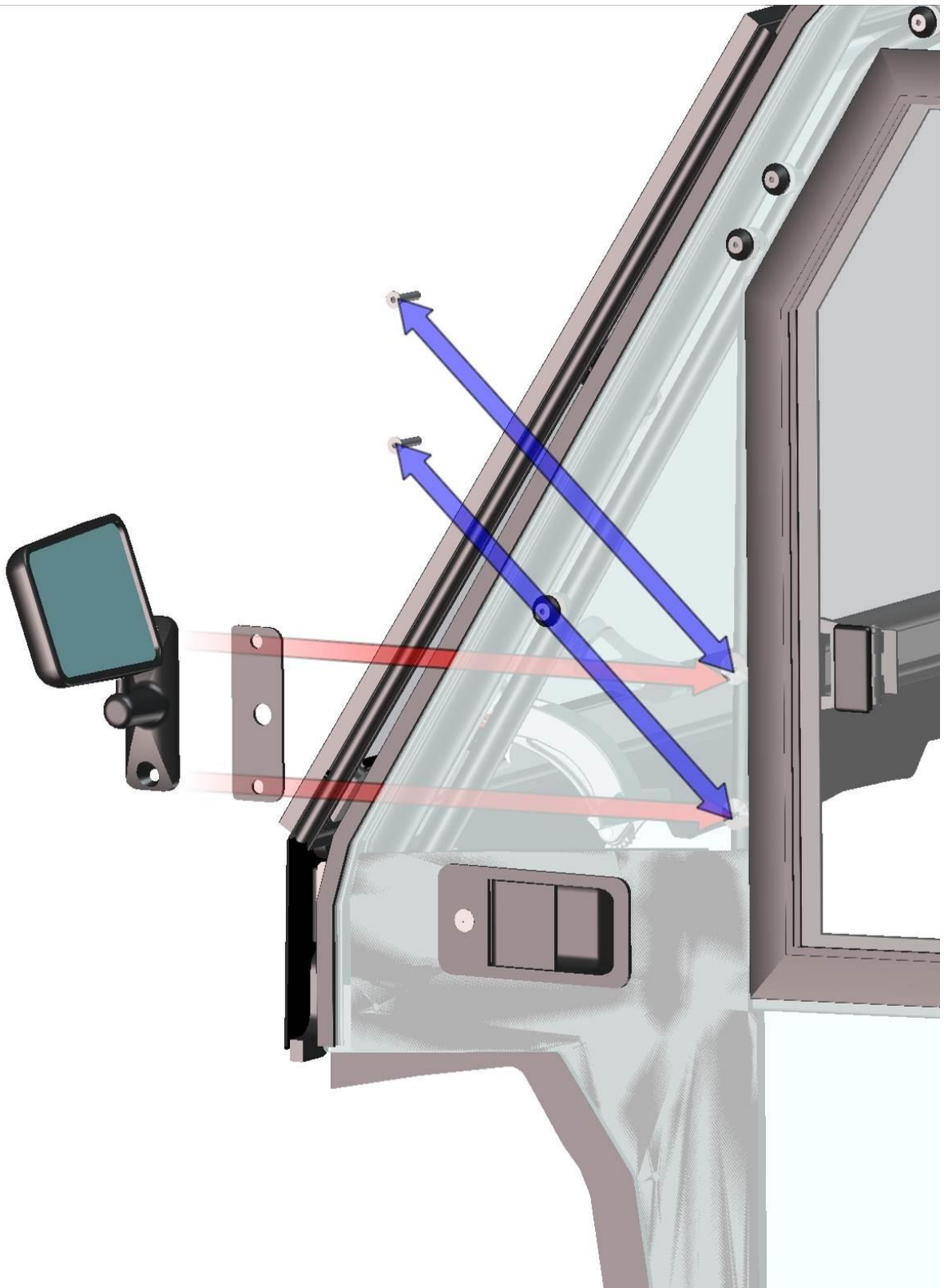

Settle EPDM of front bottom lath so that whole front bottom edge will fit tightly to the profile of dashboard. We recommend to cutting front edge of EPDM under the angle 35° for better sticking to the frame.



**ELECTROINSTALLATION – WASHER SYSTEM:**

Overall wiring diagram (wiper, washer, heating).

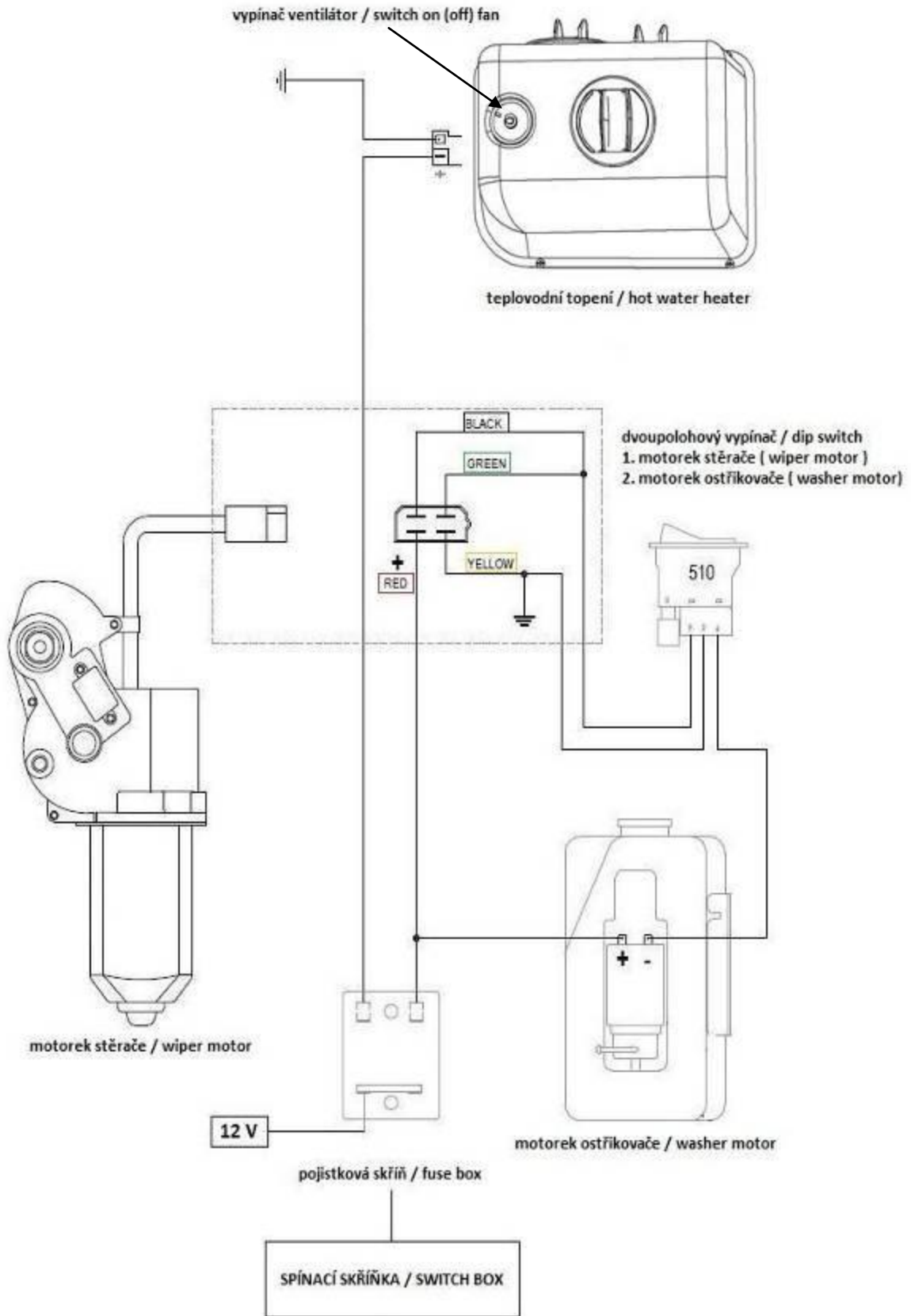

Accessories for mounting the bottle washer.

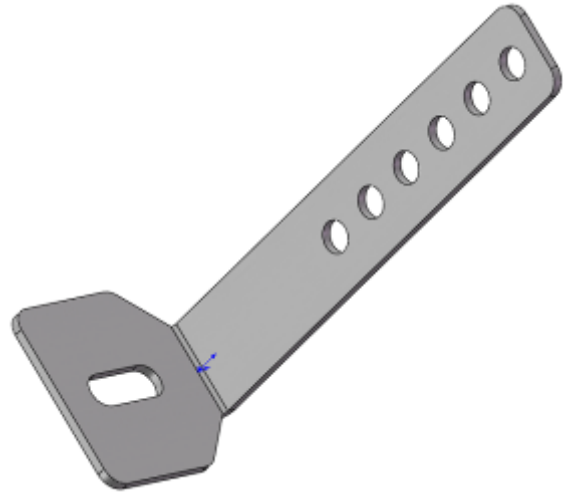

Bottle washer has to be placed below the driver seat near to the battery. Electrical wiring for the washer is kept in a harness.





Connect the harness branch no.: 1 and washer hose with the washer pump. (detail)



Uninstall the plastic cover original screw.



FOR ALL TECHNICAL QUESTIONS, PLEASE CALL  
DFK AMERICA INC.  
(630) 324-6793

Dismount the plastic cover on the cabin floor of the UTV's body.

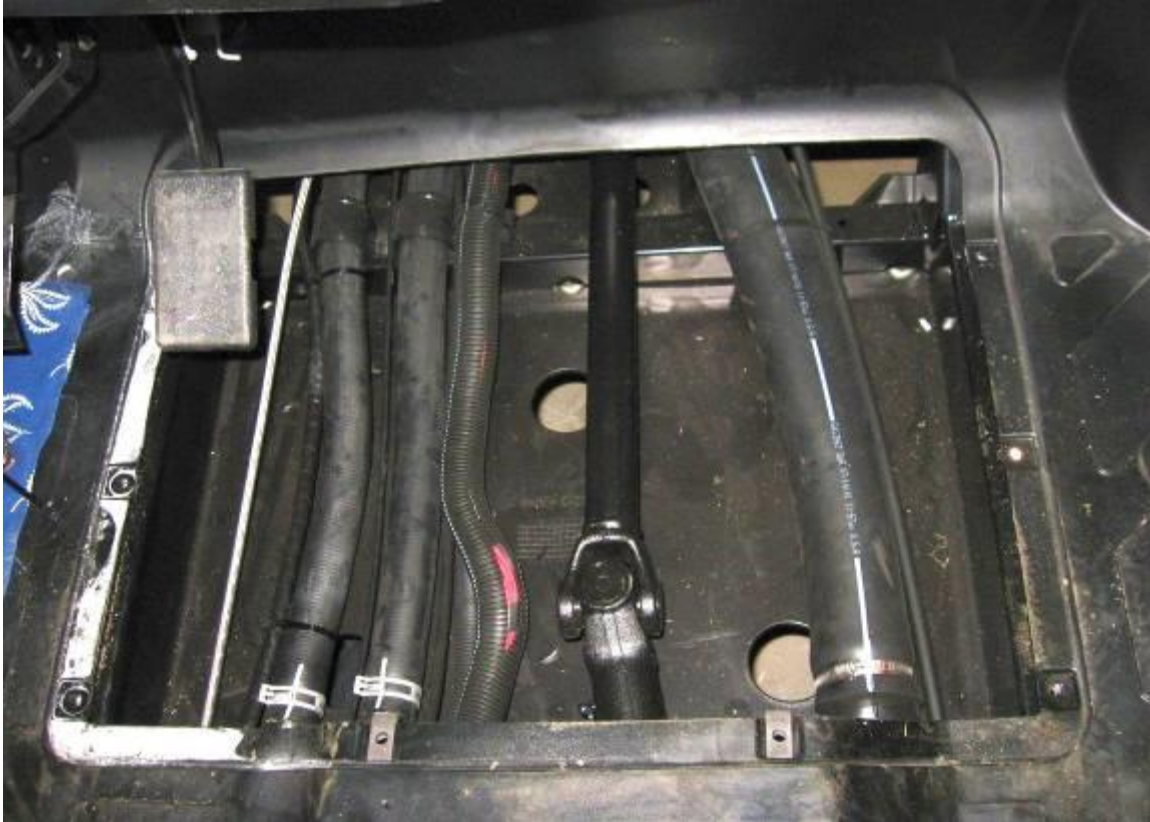

Stretch the harness through the UTV's floor tunnel.



*FOR ALL TECHNICAL QUESTIONS, PLEASE CALL  
DFK AMERICA INC.  
(630) 324-6793*

Pull out the plastic rivet from the plastic cover. Dismount the plastic cover of the left front wheel.



Lead the harness from the floor tunnel to the front battery box as the arrows show at the picture.



Next step of the leading.



Pull out the plastic rivet from the central dashboard panel.



Uninstall the central dashboard panel.



FOR ALL TECHNICAL QUESTIONS, PLEASE CALL  
DFK AMERICA INC.  
(630) 324-6793

Connect the harness branch no.:2 with main UTV's switch (In red circle).



Detail of connection.



FOR ALL TECHNICAL QUESTIONS, PLEASE CALL  
DFK AMERICA INC.  
(630) 324-6793

Cut the rectangle hole 42,1x22,1mm into the central dashboard panel.



Stretch the harness branch no.:3 trough the hole for switch and connect with switch „wiper/washer“ (in red rectangle).



Detail of connection.



View from the battery box.

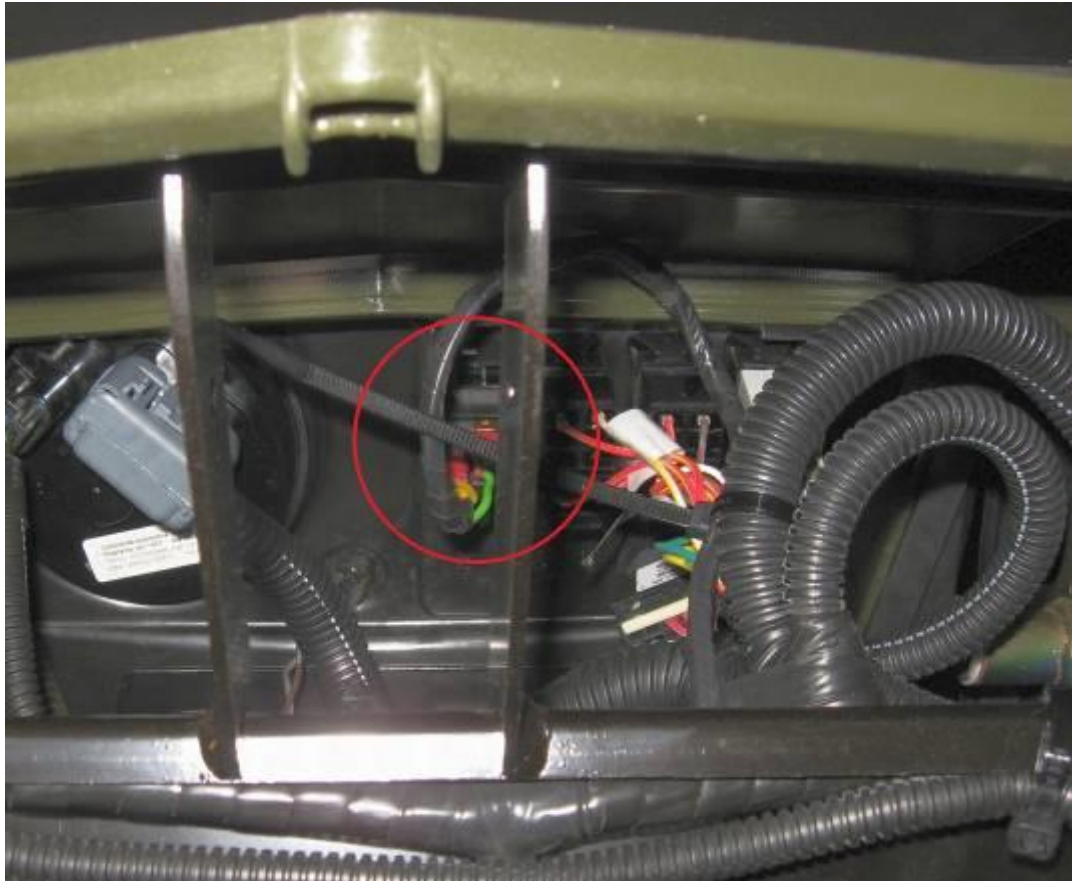

FOR ALL TECHNICAL QUESTIONS, PLEASE CALL  
DFK AMERICA INC.  
(630) 324-6793



Drill hole  $\phi 12\text{mm}$  (0,5 in) onto the dashboard near the right front roller cage.



Continue with the wiring inside the dashboard and lead it up on the left side of the roller cage to the wiper motor.  
Runs along the original wiring harness in the dashboard.

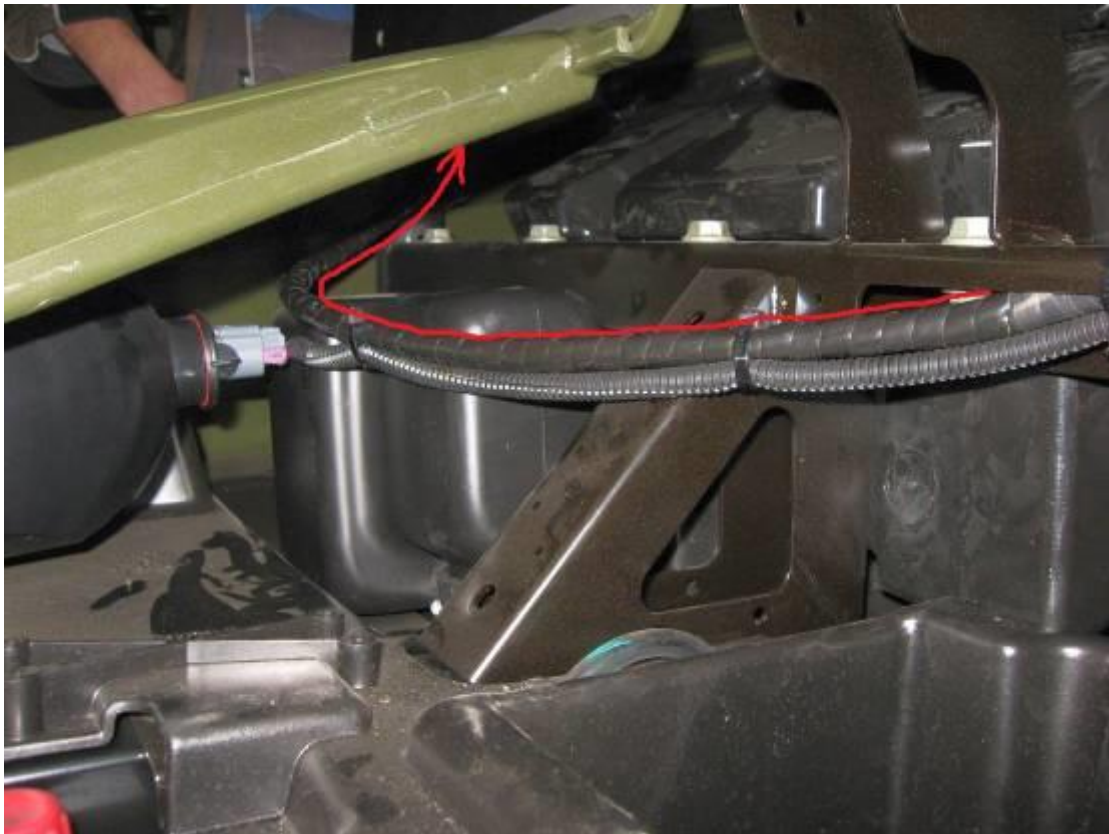

FOR ALL TECHNICAL QUESTIONS, PLEASE CALL  
DFK AMERICA INC.  
(630) 324-6793

Stretch the harness branch no.:4 through the hole.



Lead the harness branch no.:4 around the right front part of the roller cage and around roof



Allow the screw in the wiper motor cover and take the cover out.  
Connect the harness branch no.:4 with the wiper motor.

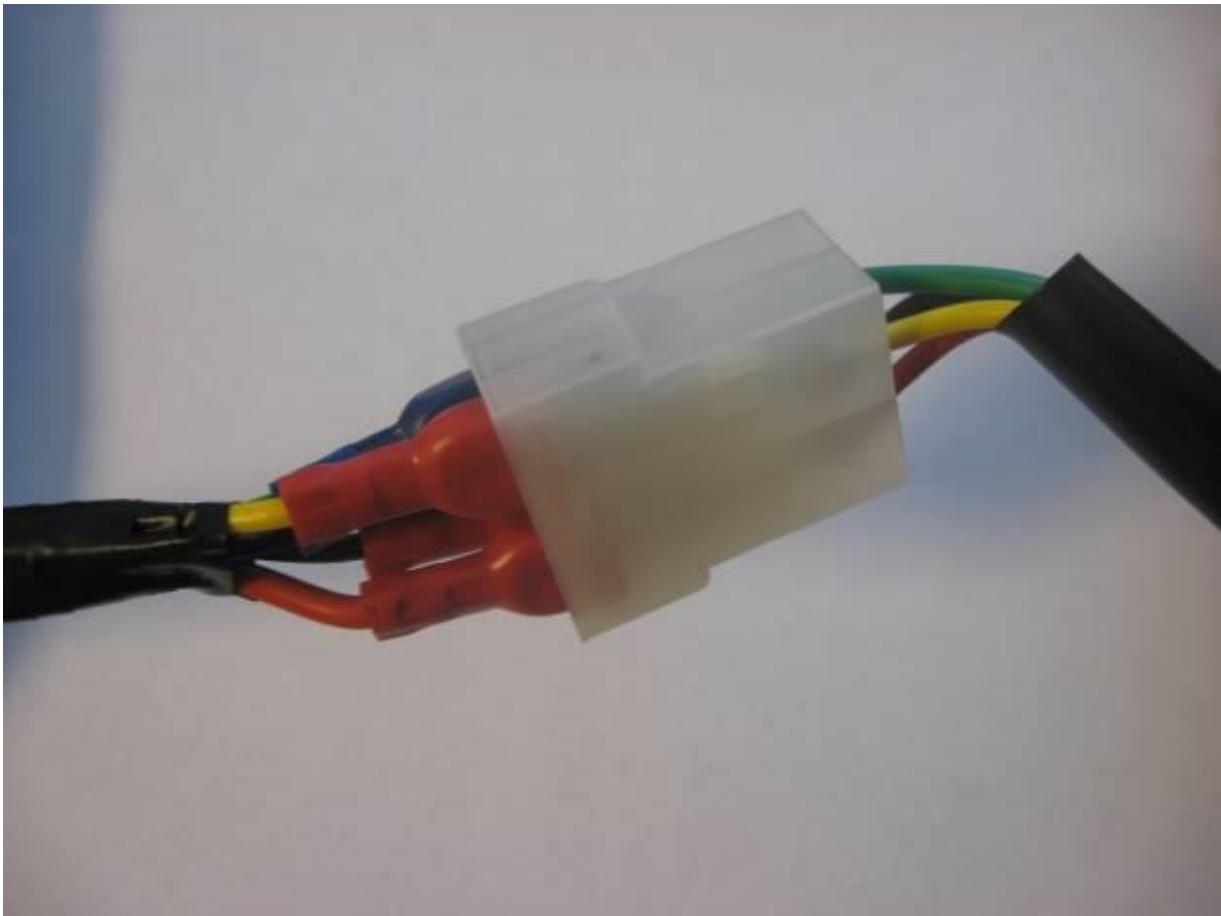

Connect the washer hose from the harness with the washer jet on the wiper arm.  
Fill the water to the washer tank before starting usage.

*FOR ALL TECHNICAL QUESTIONS, PLEASE CALL  
DFK AMERICA INC.  
(630) 324-6793*

**ELECTROINSTALLATION – HEATER SYSTEM:**

The cabin can be supplied with 2 different types of heaters – Type “A” and type “B”.

If in installation instructions is not specified to the which type of heater is concerned step, then the step is the same for both types.

Accessories for mounting the heater system for **heater type “A”**  
harness



Y coupling

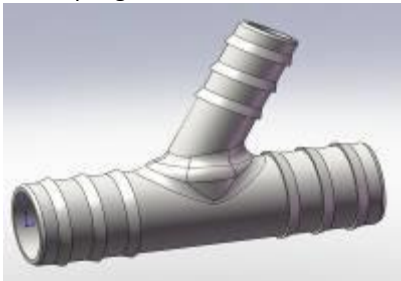

tightening straps



screw rivets



vent switch



heating holder

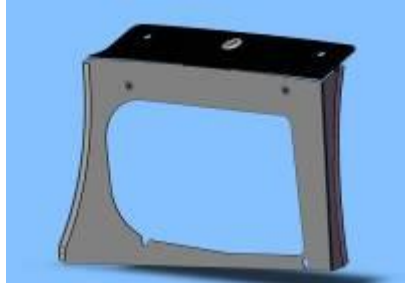

heater

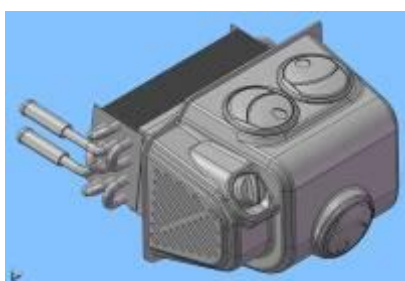

electromagnetic vent



bottom part of heater holder



flange for PETROL engine



air vent valve



heater tube for DIESEL engine



**IMPORTANT**

**IT IS ABSOLUTELY NECESSARY TO TAKE OUT THE RUBBER PLUGS FROM THE HEATER TUBES!!!**

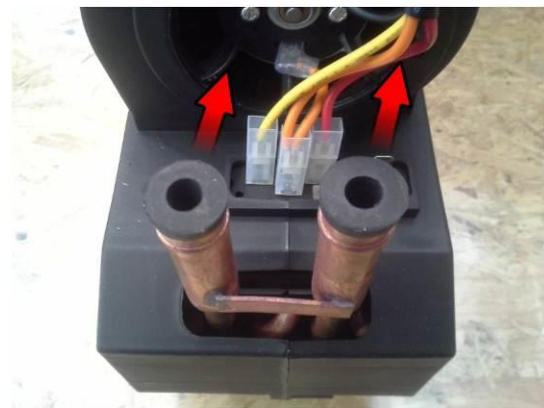
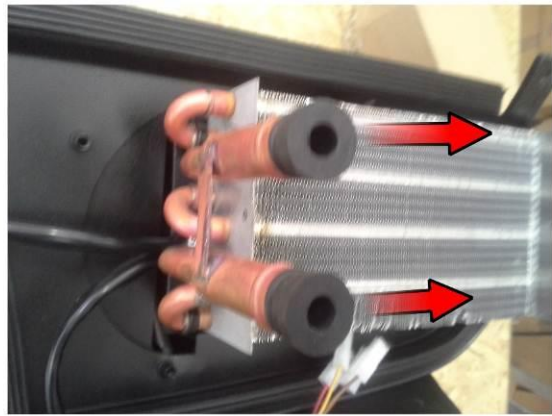

Accessories for mounting the heater system for **heater type "B"**  
harness



heating holder



Y coupling

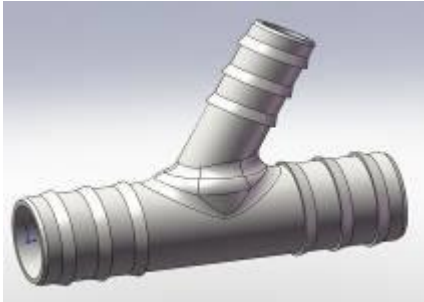

heater

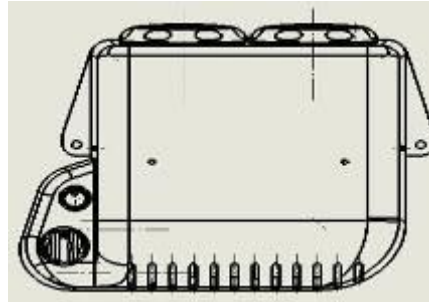

tightening strap



screw rivets



flange for PETROL engine



air vent valve



heater tube for DIESEL engine



Heater is designed to be inside the glove box at the dashboard.

Uninstall door of the glove box from the hinge.



Drill 2 holes  $\phi$  25mm (1 in) on the left side of the glove box at the dashboard.



FOR ALL TECHNICAL QUESTIONS, PLEASE CALL  
DFK AMERICA INC.  
(630) 324-6793

Outside view from the front side. (Holes are in red circles)  
Drill the hole  $\varnothing$  12 mm (0,5 in) to the upper side of glove box.



Insert hot water hoses and harness into the holes.



FOR ALL TECHNICAL QUESTIONS, PLEASE CALL  
DFK AMERICA INC.  
(630) 324-6793



Connect the hoses with the pipes of the heater. **(Heater type "A")**



Connect the harness branch no.: 3 with heater (detail of connection). **(Heater type "A")**

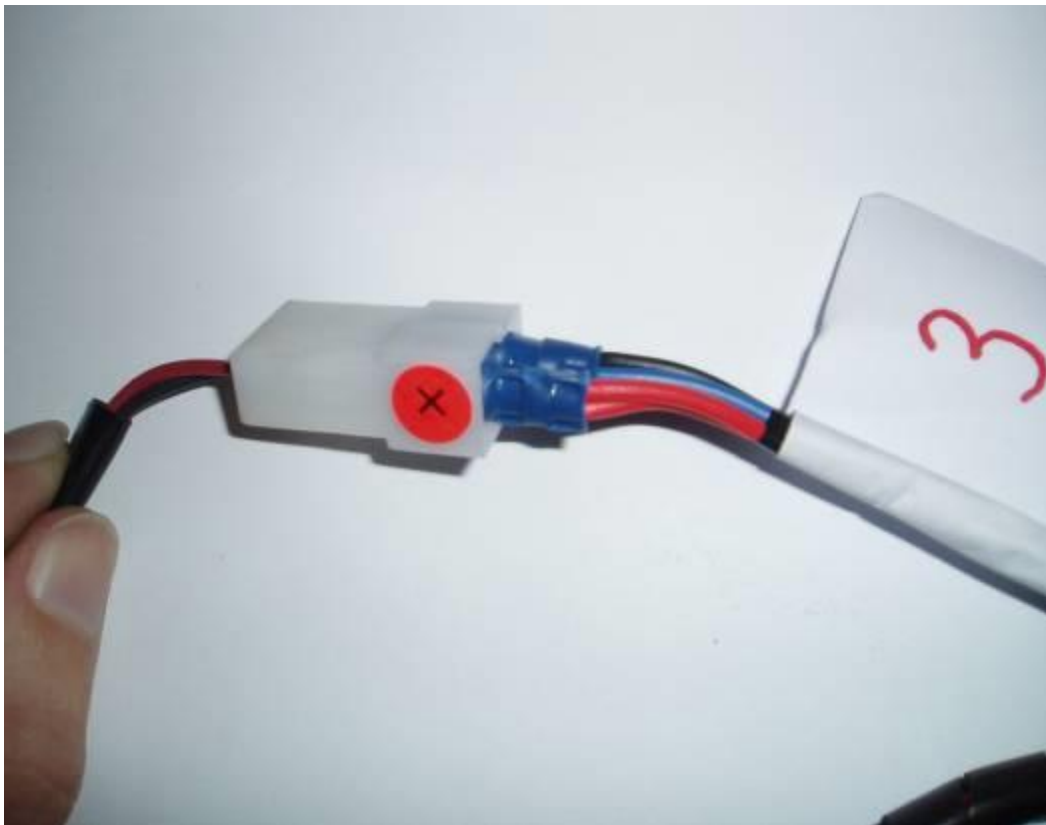

FOR ALL TECHNICAL QUESTIONS, PLEASE CALL  
DFK AMERICA INC.  
(630) 324-6793

Connect the harness of heater with switcher in heater cover. (Heater type "A")  
Pull out the plastic button from switch.



Uninstall the nut from switch and pull the switch out from the cover.



View on to the switch assembly.

Connect the heater harness with switch.



View on to connected harness. Install switcher back into the heater cover.



Connect the harness branch no.: 4 to the electric vent switch on the heater cover. **(Heater type "A")**  
When the switch is backlit, electric vent is turn off and hot water from engine cooling don't run in heater.



Place the bottom part of heater holder onto the position (outlines in red).  
Insert the heater to the glove box (left side first). **(Heater type "A")**



FOR ALL TECHNICAL QUESTIONS, PLEASE CALL  
DFK AMERICA INC.  
(630) 324-6793

Insert the heater holder onto the dashboard, drill 3 holes  $\phi 8\text{mm}$  (0,31-0,33 in), insert screw rivet and tighten.  
**(Heater type "A")**



Fix the heater cover with heater holder by 4 x screw M5x20 (2 upper screws are in red circles). **(Heater type "A")**



For placing of the electric vent cut the water tube connected to the upper pipe of the heater and insert the electric vent.  
Fix the water tube with vent by tightening strap.  
The vent must be in same orientation like in picture. **(Heater type "A")**



Connect the harness branch no.: 2 with the vent. Detail of connection. **(Heater type "A")**



FOR ALL TECHNICAL QUESTIONS, PLEASE CALL  
DFK AMERICA INC.  
(630) 324-6793

**Instructions for heater type "B"**

Connect the water hose with electric vent and fix these by tightening straps. **(Heater type "B")**



Connect the water hose with water tube and fix these by tightening straps. **(Heater type "B")**



Connect the harness branch no.:1 with the heater harness (detail view.) **(Heater type "B")**

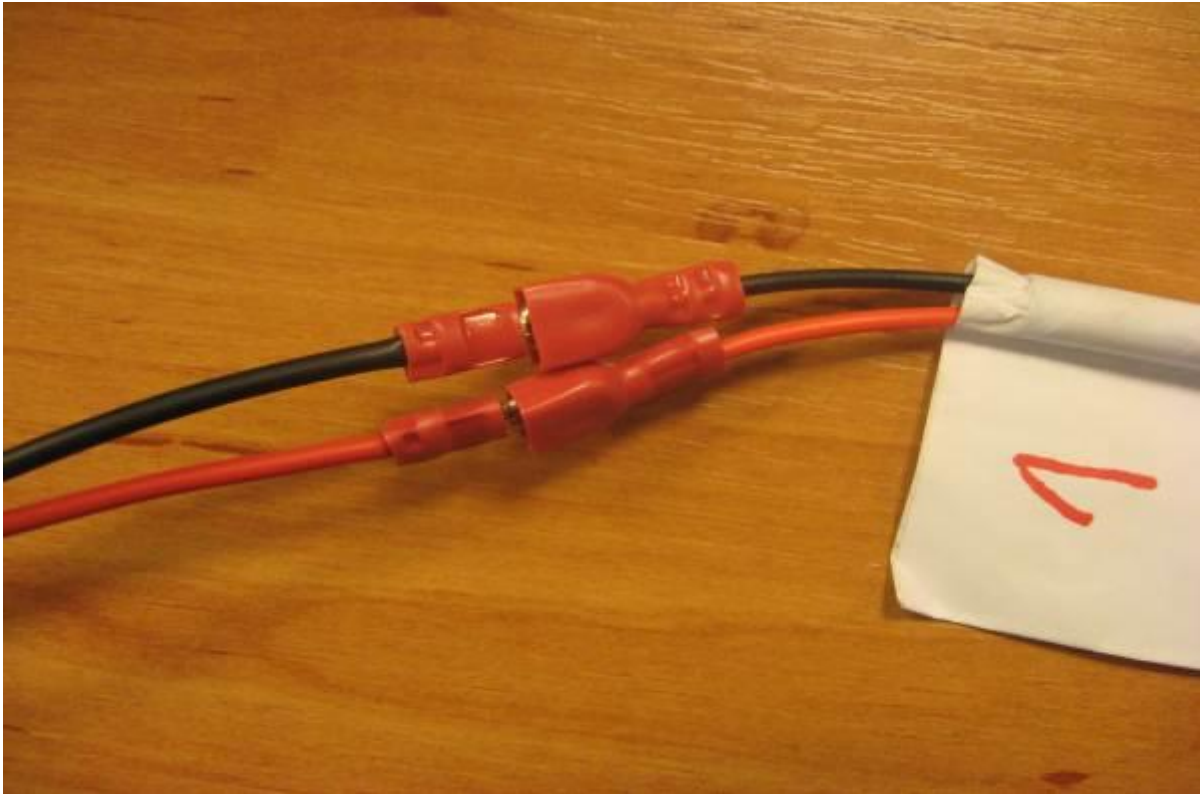

Place the heater holder on position and make marks according with holes. **(Heater type "B")**



FOR ALL TECHNICAL QUESTIONS, PLEASE CALL  
DFK AMERICA INC.  
(630) 324-6793

Drill 4 holes  $\phi 8\text{mm}$ (0,31-0,33 in) into dashboard according with holes on the heater holder, insert screw rivet and tighten. **(Heater type "B")**



Connect the harness branch no.: 1 with main switch of the UTV. **(Heater type "A")**

Connect the harness branch no.: 2 with main switch of the UTV. **(Heater type "B")**

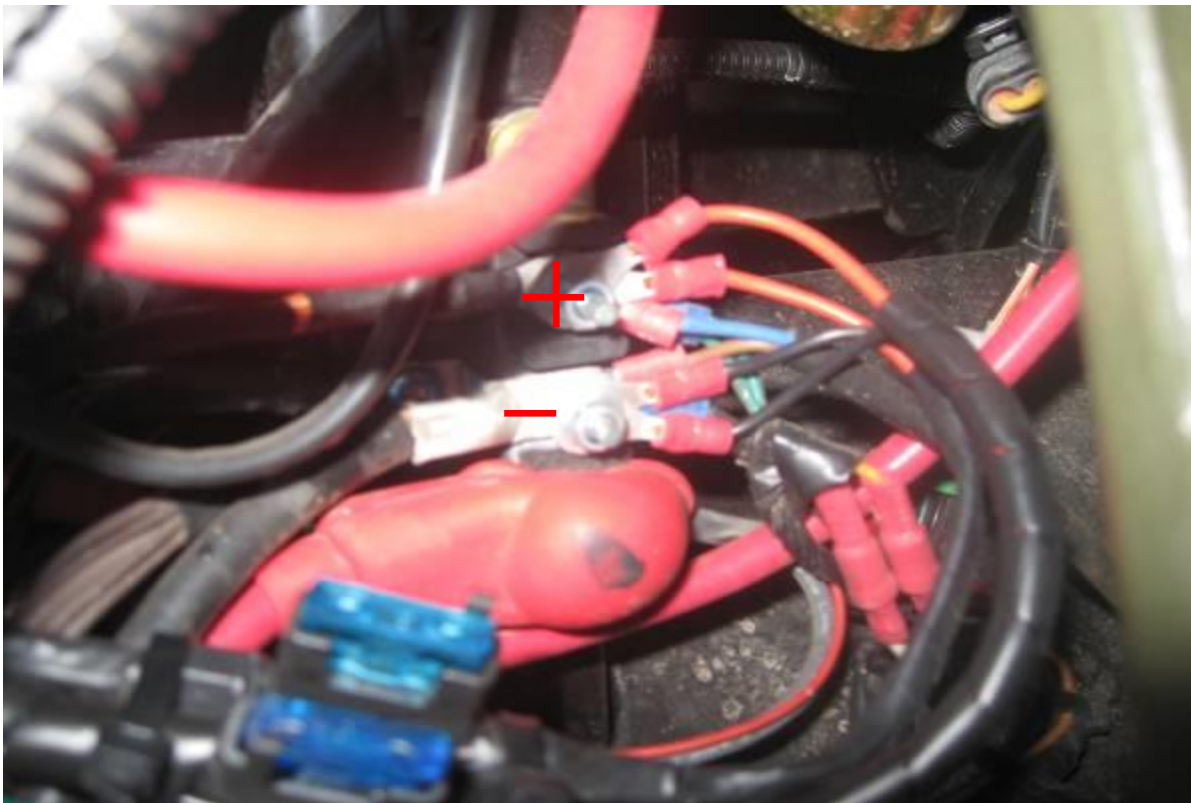

FOR ALL TECHNICAL QUESTIONS, PLEASE CALL  
DFK AMERICA INC.  
(630) 324-6793



Cut the hose without the electromagnetic vent and insert tightening straps onto the hose. Insert the air vent valve (in red circle) into the both end of the hose and tight the straps hard. **(For both types of heater)**



Lead the water hoses from the battery box to the floor tunnel. **(For both types of heater)**



FOR ALL TECHNICAL QUESTIONS, PLEASE CALL  
DFK AMERICA INC.  
(630) 324-6793

Detail view on the right rear corner of the front battery box.



View onto the right bottom part of the UTV's. (Near right front wheel).



FOR ALL TECHNICAL QUESTIONS, PLEASE CALL  
DFK AMERICA INC.  
(630) 324-6793

Water hoses in the floor tunnel.



Cut the water hose (red line) with air vent valve to correct length. Lead the water hose with electromagnetic vent (orange arrow) from tunnel to the UTV's engine.

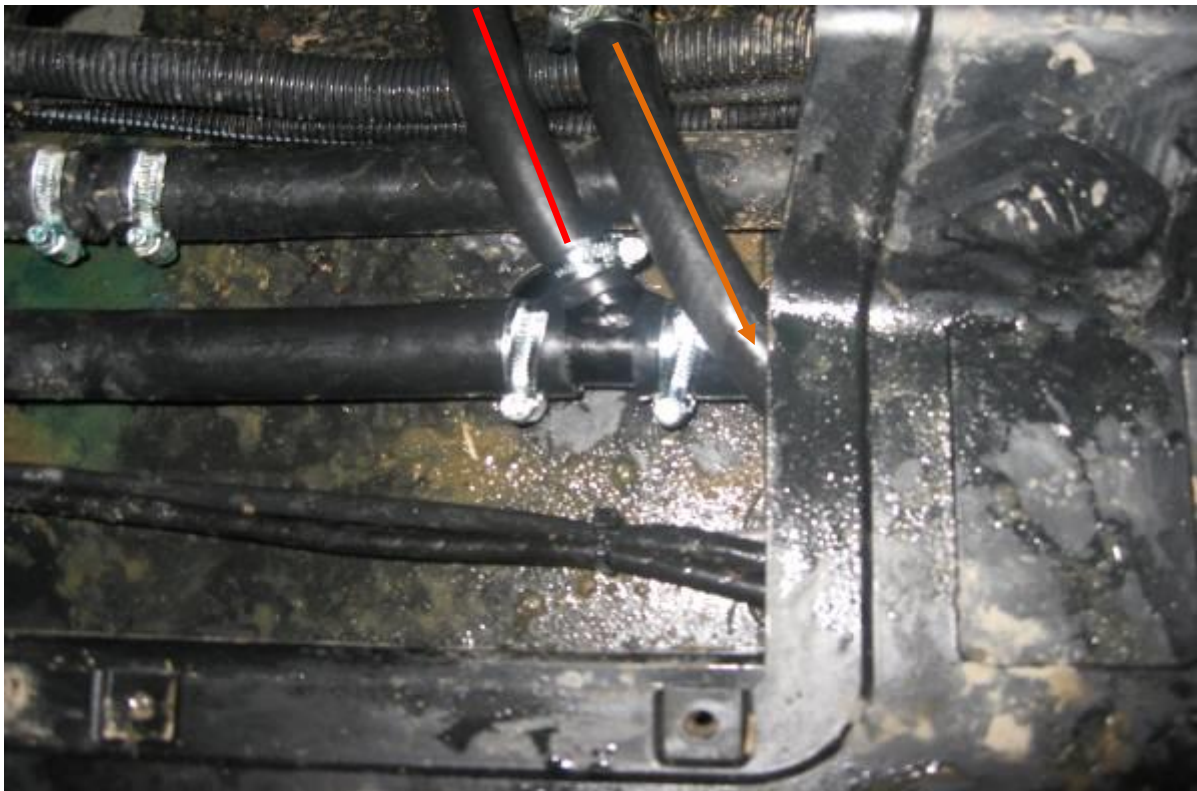

Insert the tightening straps and T coupling into the short water hose.

FOR ALL TECHNICAL QUESTIONS, PLEASE CALL  
DFK AMERICA INC.  
(630) 324-6793

Secure the original left water hose (run water back to engine) on both sides using lockable pliers or clamps to avoid lose of cooling liquid. Cut the original water hose and insert the tightening straps on both ends. Insert the Y coupling (red ellipse) into the original water hose and tight the straps very hard.



Take out the pliers from the original water hose.

**NEXT FEW STEPS ARE FOR INSTALLATION ON PETROL ENGINE**

Uninstall the thermostat flange from the engine and connect that with flange (included with cabin). You may have to disconnect the original water hose from the thermostat flange before uninstallation.

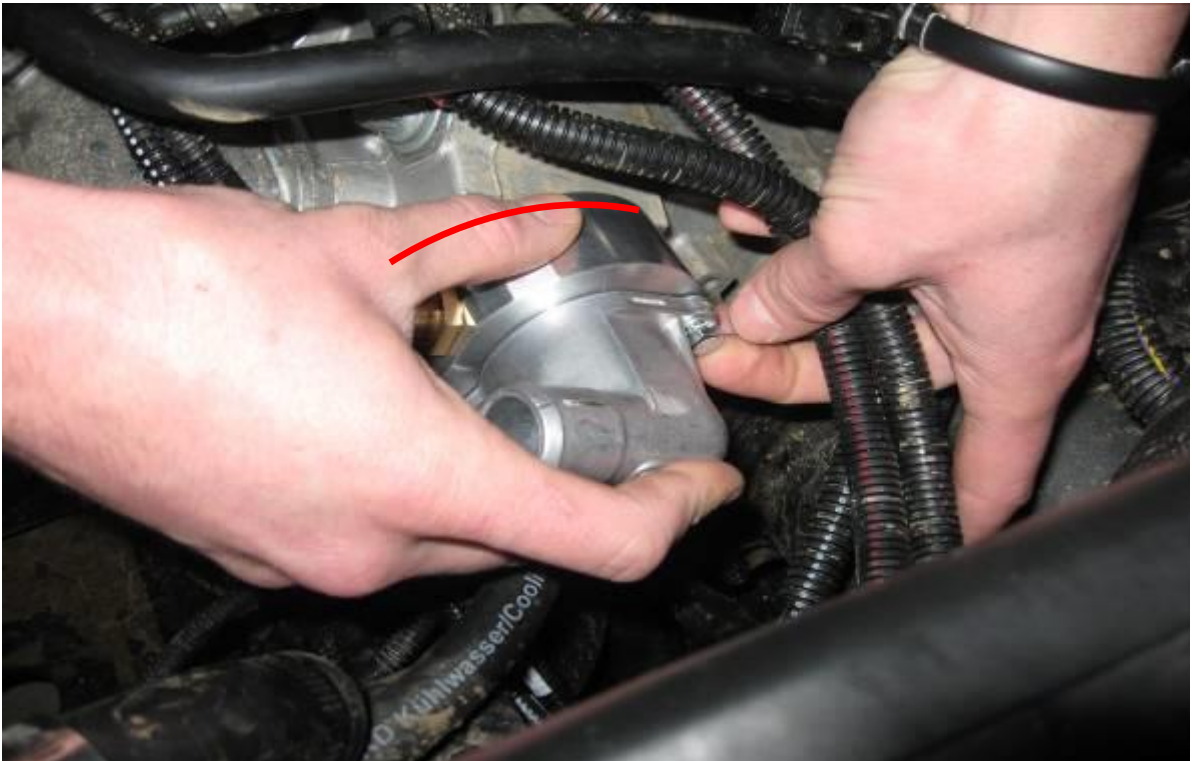

You have to place the included flange rubber side (red line) on engine. (For detail of flange see pages No.:51, 52)

FOR ALL TECHNICAL QUESTIONS, PLEASE CALL  
DFK AMERICA INC.  
(630) 324-6793

Place the original flange with included flange back to position on engine and fix these by 2 screws M6x50 and washers. Insert tightening strap on the water hose and connect the hose with tube on the flange and tighten the strap very hard.

You can install back the original hose to the original flange.



77

**NEXT FEW STEPS ARE FOR INSTALLATION ON DIESEL ENGINE**

Take out the seat from the UTV and uninstall the original screw (in red circle) from the UTV's engine.



(Detail view on next page)

FOR ALL TECHNICAL QUESTIONS, PLEASE CALL  
DFK AMERICA INC.  
(630) 324-6793

Detail view



Drop the screw glue on heater tube and insert the heater tube instead of the original screw and tighten very hard. Insert the tightening strap on the heater hose and insert hose on the heater tube. Tighten the strap very hard.



**SEE NEXT PAGE**

**FOR BOTH TYPE OF THE HEATER AND THE UTV'S ENGINE**

FOR ALL TECHNICAL QUESTIONS, PLEASE CALL  
DFK AMERICA INC.  
(630) 324-6793

**Important notice:**

- 1. Before the first turning on the hot water heater it is necessary to check the tightness of the cooling circuit of the hot water heater.**
  - 2. Insert more cooling liquid to the cooling circuit.**
  - 3. Turn UTV's engine on and open the air vent valve.**
  - 4. Turn heater on and wait for the maximum temperature. When the cooling liquid starts to leak from the air vent valve close the valve.**
- Turn off heater and add more cooling liquid to the cooling circuit if need it.**

**In cab units where you are installing the glove compartment heater provided in the standard DFK Cab Kit, it is important to check the coolant level regularly at least 4-5 times during the first several days of operation and fill as necessary until the coolant level has stabilized.**

**The heater will draw and retain coolant, sometimes at the expense of coolant to the engine.**

**This can cause engine overheating if not managed properly.**