



INSTALLATION INSTRUCTIONS

CAM-AM
DEFENDER MAX

HardCabs →



SAFETY INSTRUCTIONS

Warning: Failure to heed all safety and operating instructions and warnings regarding use of this product can result in serious bodily injury.

READ PROPERLY COMPLETE ASSEMBLY INSTRUCTIONS BEFORE STARTING OF ASSEMBLY

Install all parts indicated in assembly instructions. Failure to fully assemble product before use could result in personal injury.

Assembly of product requires use of hand or power tools. If you are not experienced in using these types of tools, have product dealer do the install for you.

Some parts contain sharp edges, wear protective gloves if necessary.

Always keep your assembly area clean, uncluttered and well lit.

Keep visitors and children a safe distance away from the assembly area. Visitors should wear the same safety equipment described under.

Never operate your UTV with the cab doors open. Failure to properly latch the doors before moving the vehicle could result in serious injury.

Dress for safety. DO NOT wear loose clothing, gloves, neckties or jewelry if using power tools to assemble this product.

Insert all nut covers after you finish installation.

Never drive your UTV with the cab front window in open position. Failure to properly latch/lock front window before driving the vehicle could result in serious injury.

Please be careful not to break the plastic washers, if you're tightening screws with plastic washers use max torque of 3.7 foot-pound force (5 Nm)!!!



WARNING: For safety purposes, if the DFK Cab doors are removed, it is mandatory that the OEM manufactured Half Doors or Nets are **REINSTALLED** before operating the vehicle.

MAINTENANCE AND CLEANING

To clean polycarbonate surface use soapy water solution or other subtle means.

Dirt and dust wash by gently water stream and swipe only with wet or damp means in the direction from top to bottom.

The recommended frequency of cleaning of polycarbonate part is about 1 time per month or according to the actual degree of pollution.

*Do not use detergents that could scratch the surface plates.
(abrasives, harsh fabrics, etc.)*

*Do not use solvents or alkaline detergents or cleaners with ammonia
(ammonium hydroxide).*

Do not remove the impurities from the surface of the razor blades or other sharp items.

Do not clean cabin when the polycarbonate plates are heated by the sun.

Do not use the squeegee, it could be scratched surface plates.

Do not clean the water current strength greater than 50 bar (WAP)

The manufacturer is not responsible for scratching the surface in case of failure to comply with the above instructions.

All bolted connections of cab must be by user at regular intervals checked and tightened.

PREPARATION FOR INSTALLATION:

Uninstall all additional systems from the roller cages (work lights, rear mirrors, drink holders etc.)
It is necessary to uninstall rear side tubes (red lines) from the UTV's from both sides. Save the tubes with the original screws for later usage.



Losen the fixing screws (red circles) and uninstall the tubes.



FOR ALL TECHNICAL QUESTIONS, PLEASE CALL
DFK AMERICA INC.
(630) 324-8585

CAB PREVIEW



5

FOR ALL TECHNICAL QUESTIONS, PLEASE CALL
DFK AMERICA INC.
(630) 324-8585

FRONT PANEL

Place the front console assembly onto UTV roll cage and fix by included fixing assembly on both sides.

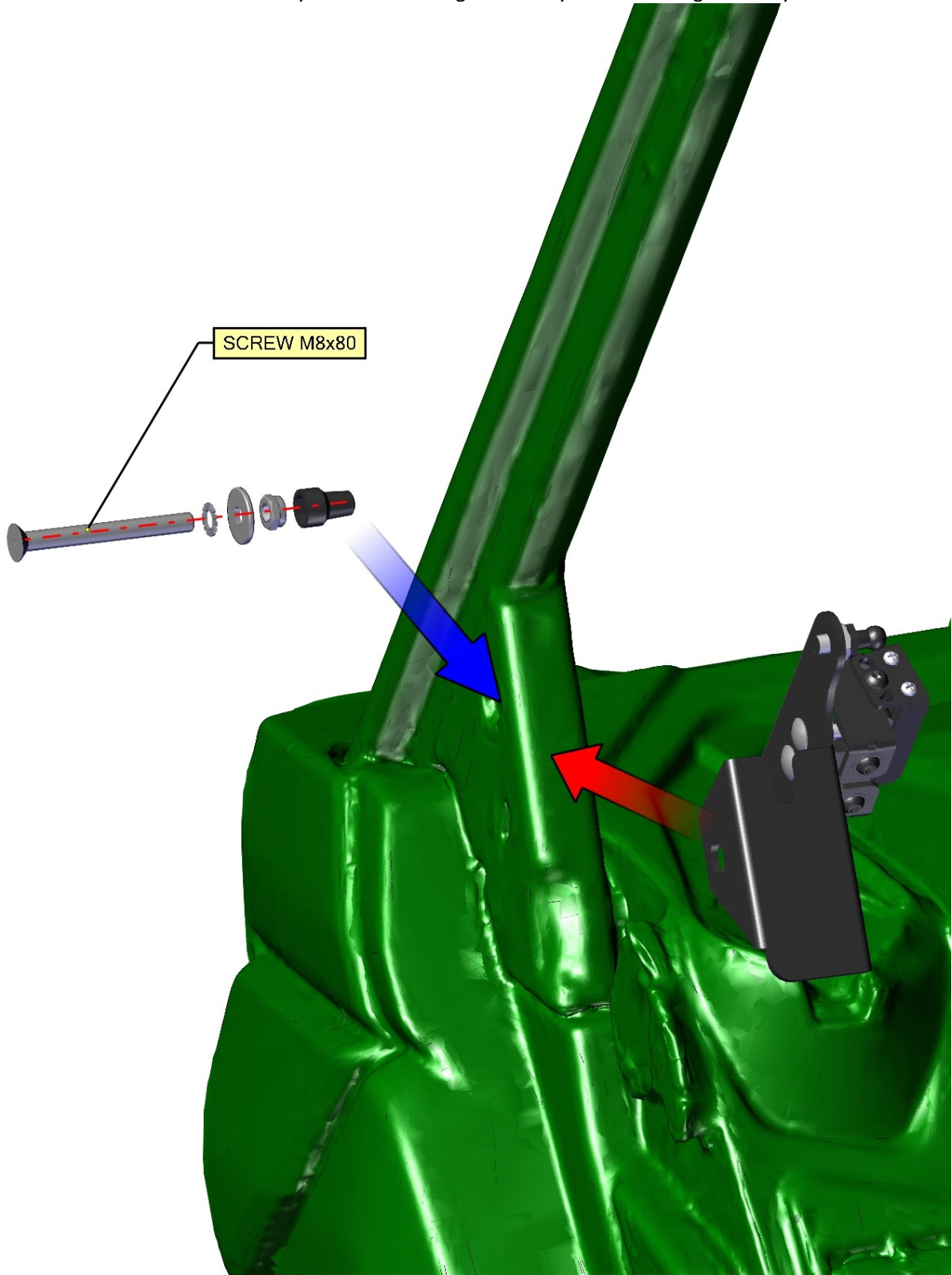

6

Place the front panel onto UTV roll cage and adjust to the best position.

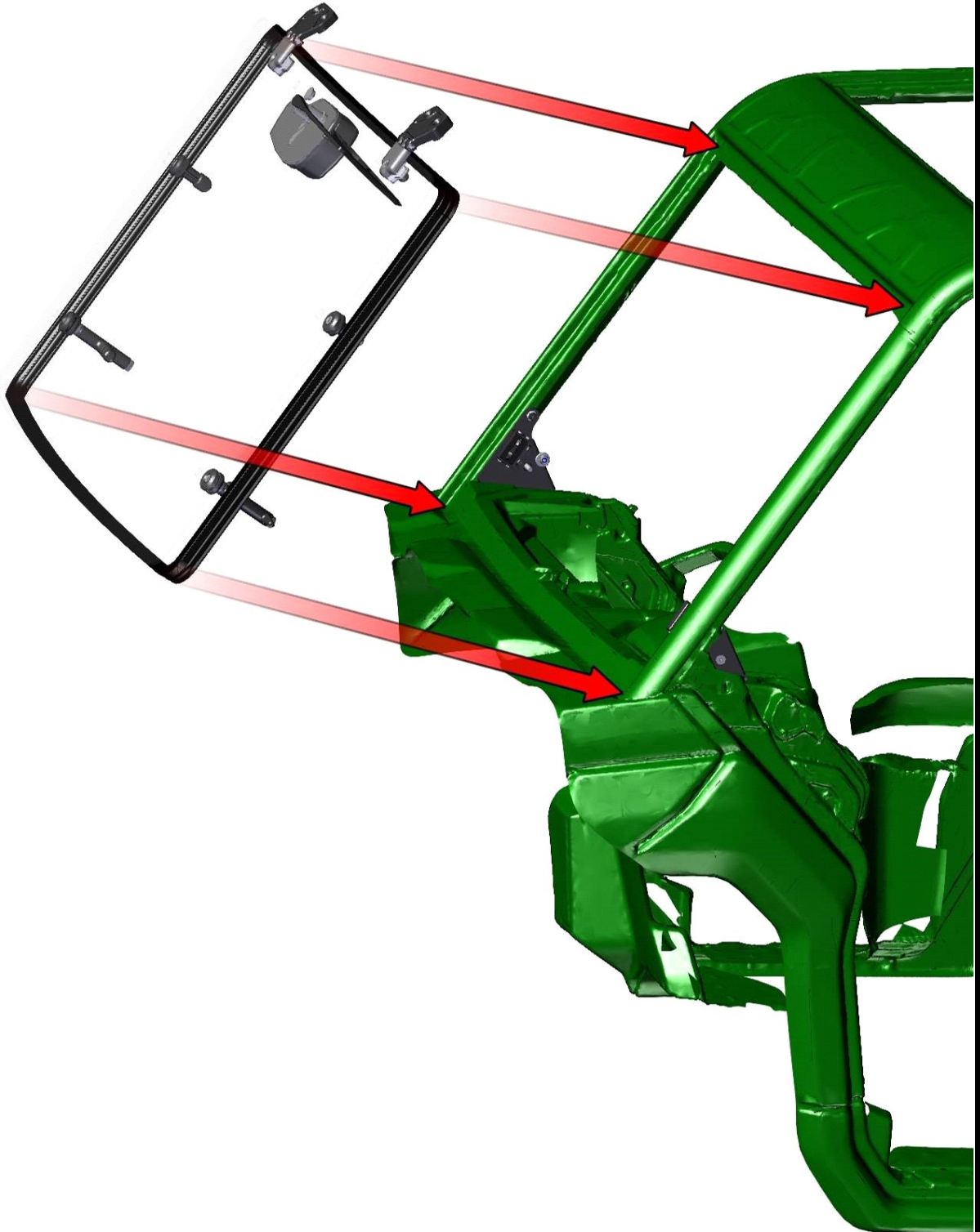

Fix the front panel with included fixing assemblies.

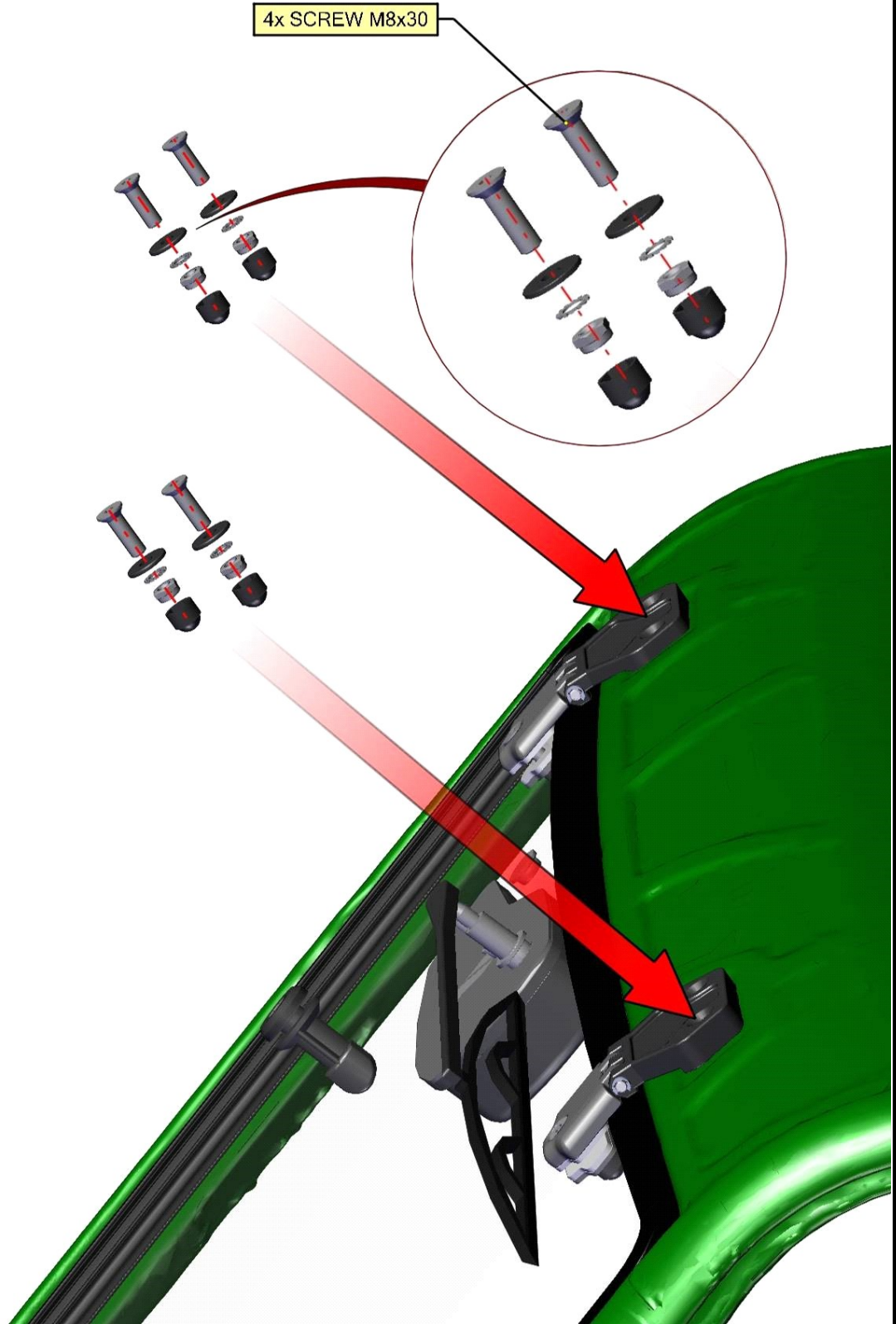

Install gas spring onto gas spring holders on both sides.

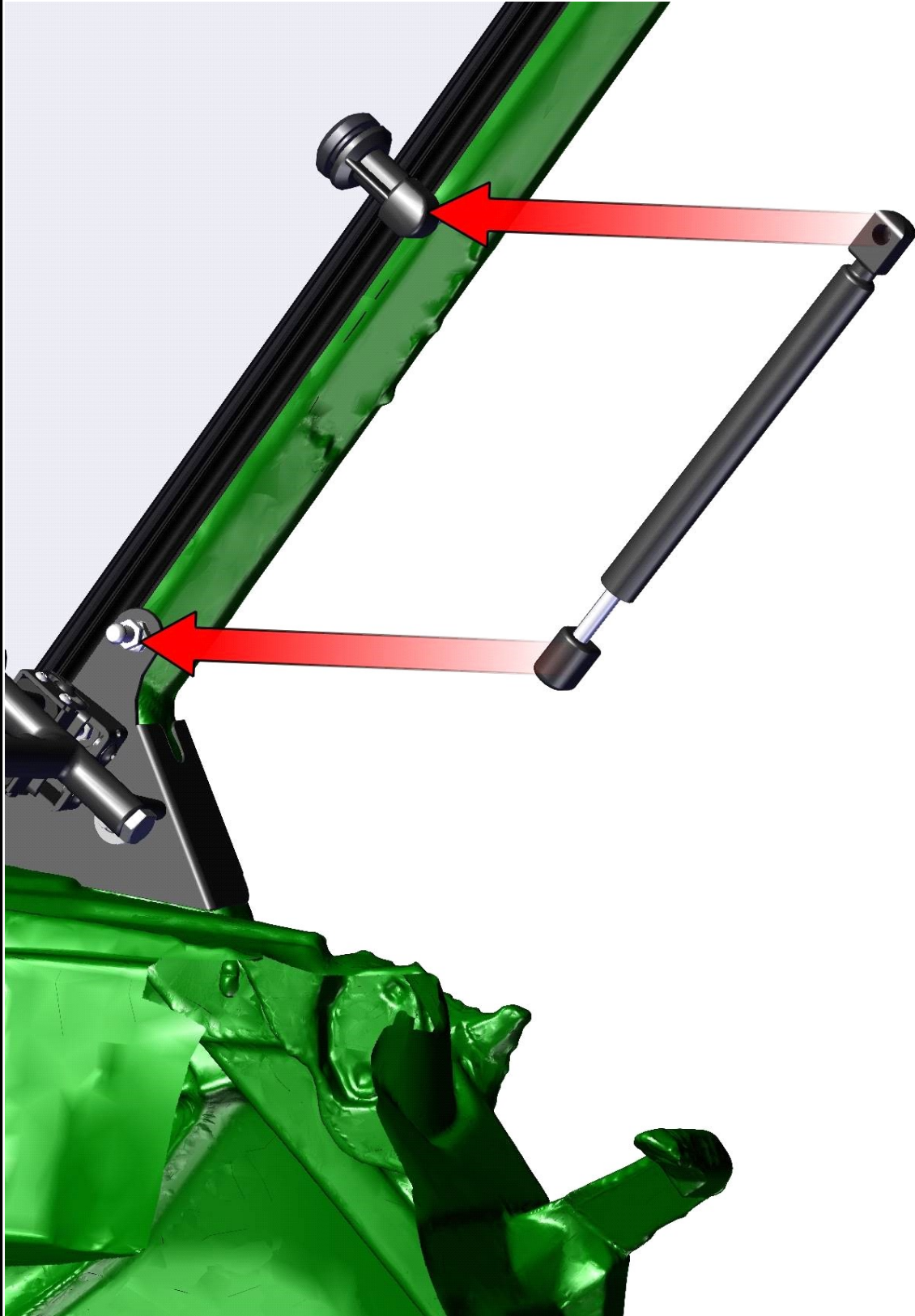

Adjust the front glass stop assembly into the best position and tighten screws hard on both sides.

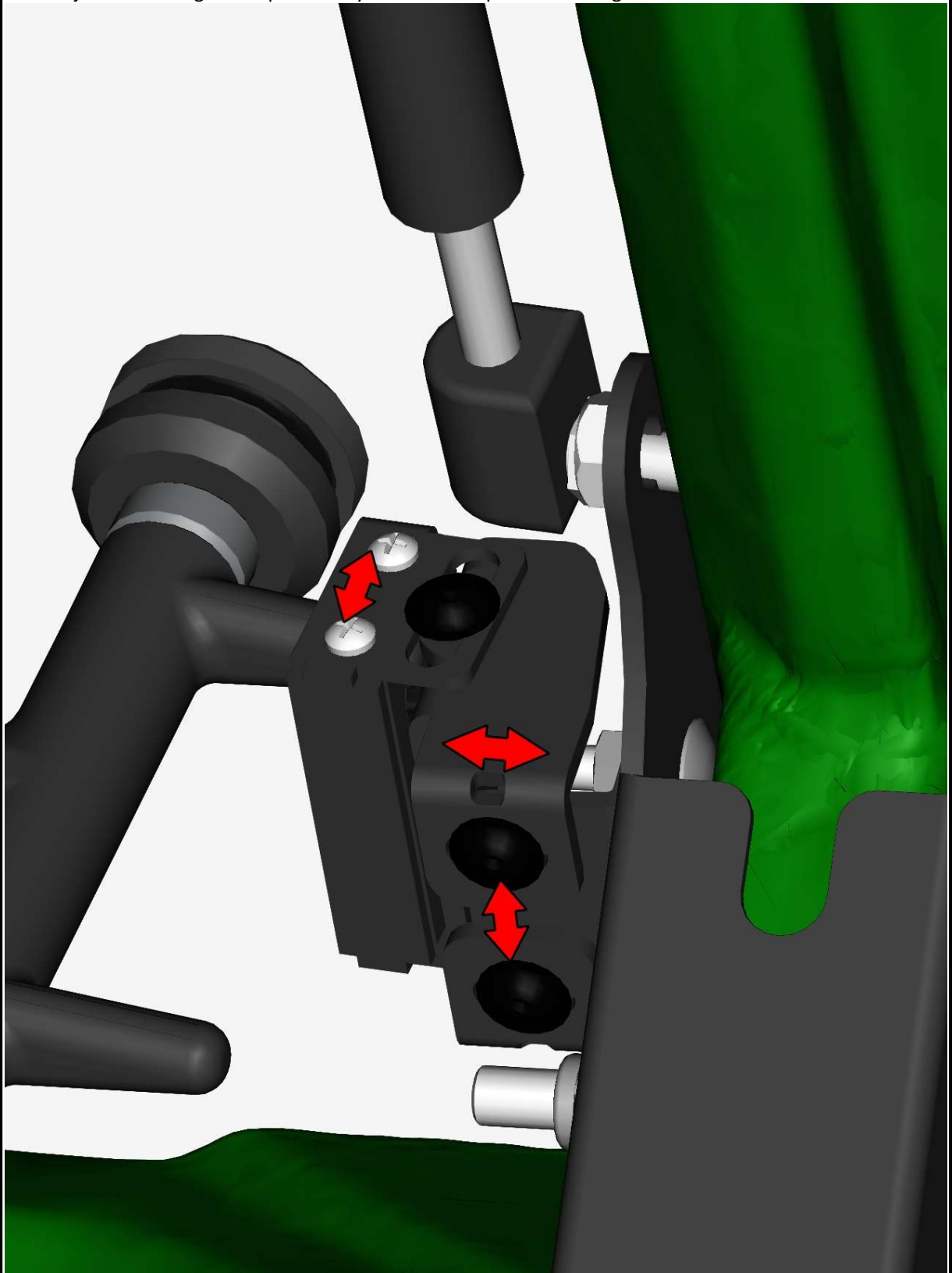

10

FOR ALL TECHNICAL QUESTIONS, PLEASE CALL
DFK AMERICA INC.
(630) 324-8585

ROOF

Uninstall the rear roof panel holders screw before the rear roof panel installation.

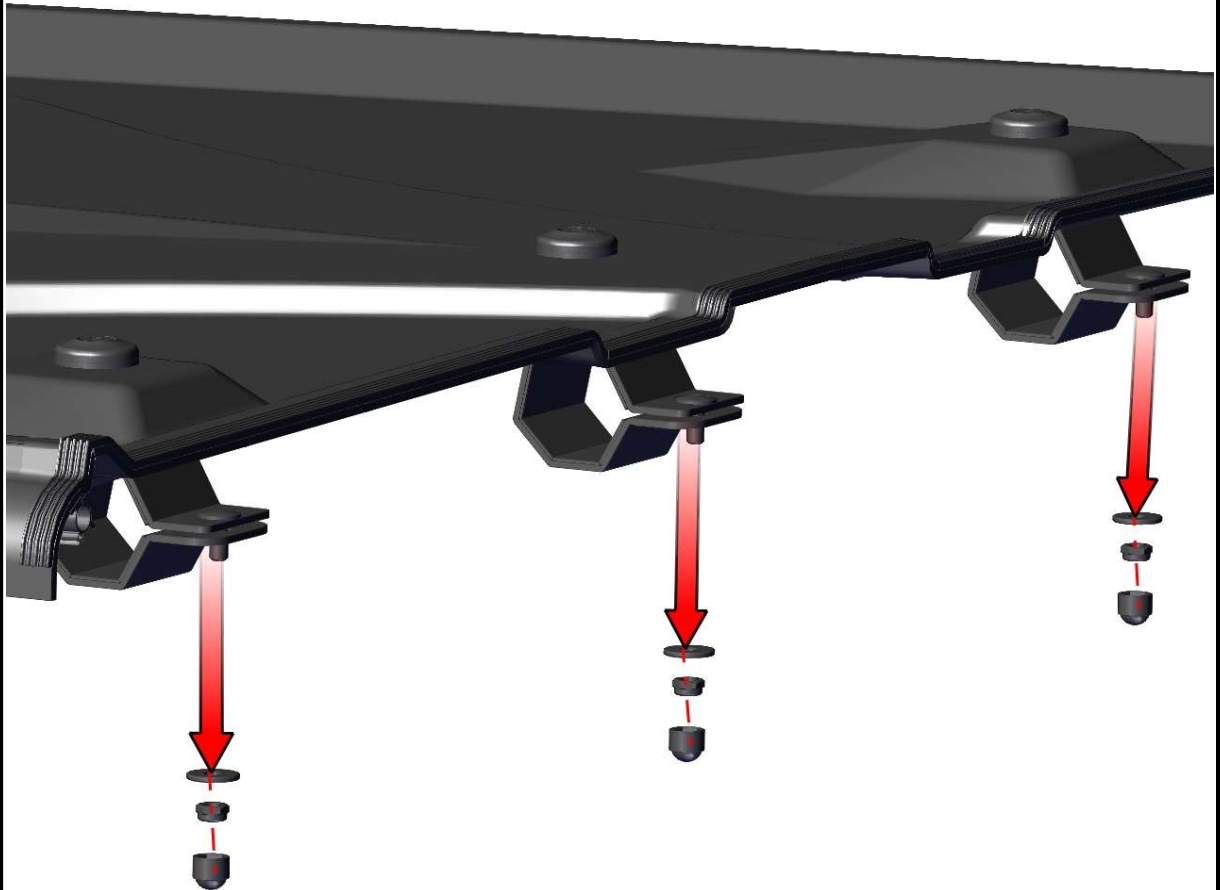

11

Place and adjust the rear roof panel onto the UTV roll cage.

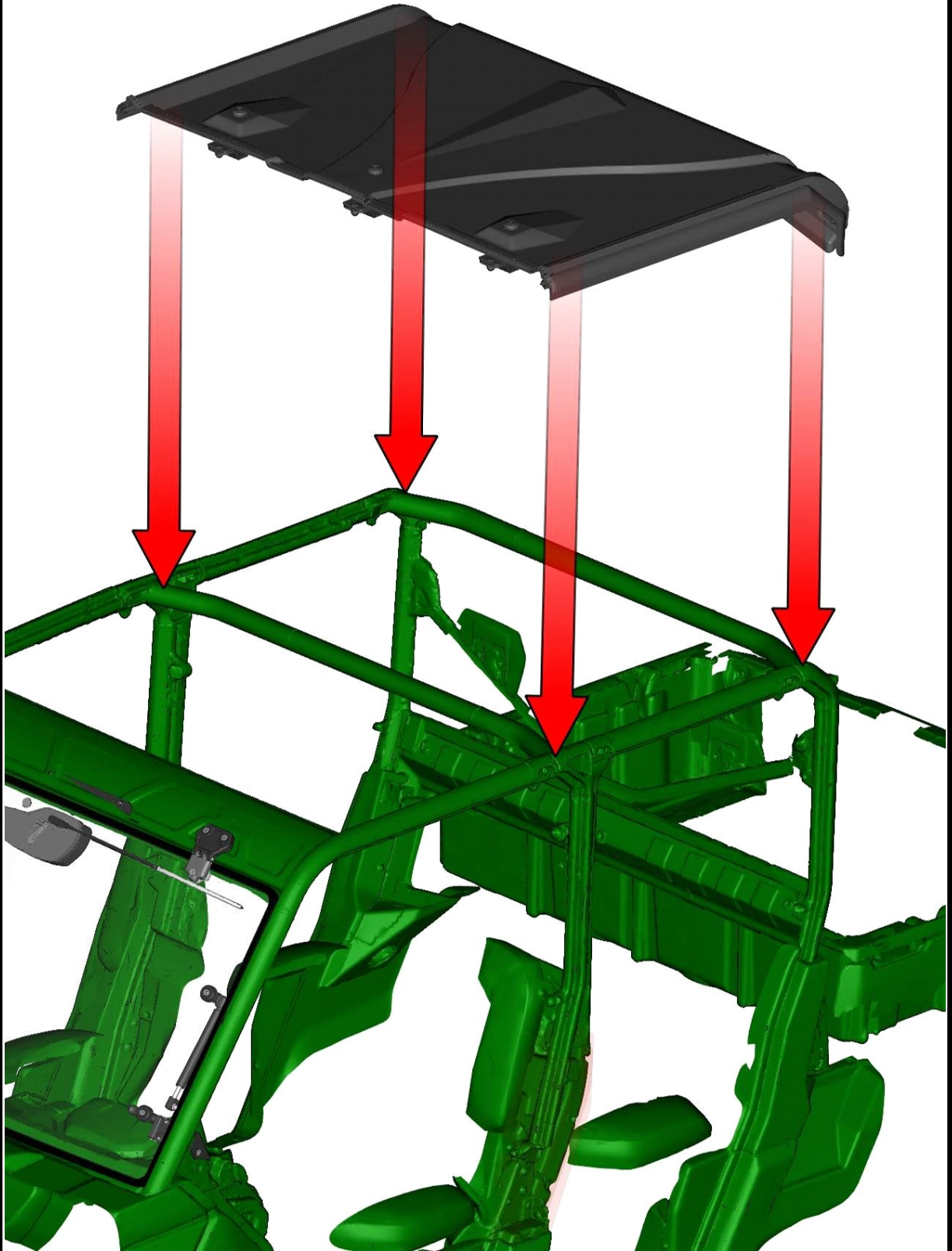

12

FOR ALL TECHNICAL QUESTIONS, PLEASE CALL
DFK AMERICA INC.
(630) 324-8585

Close the rear roof panel holders and fix with included washers, screws and covers. Tighten hard.

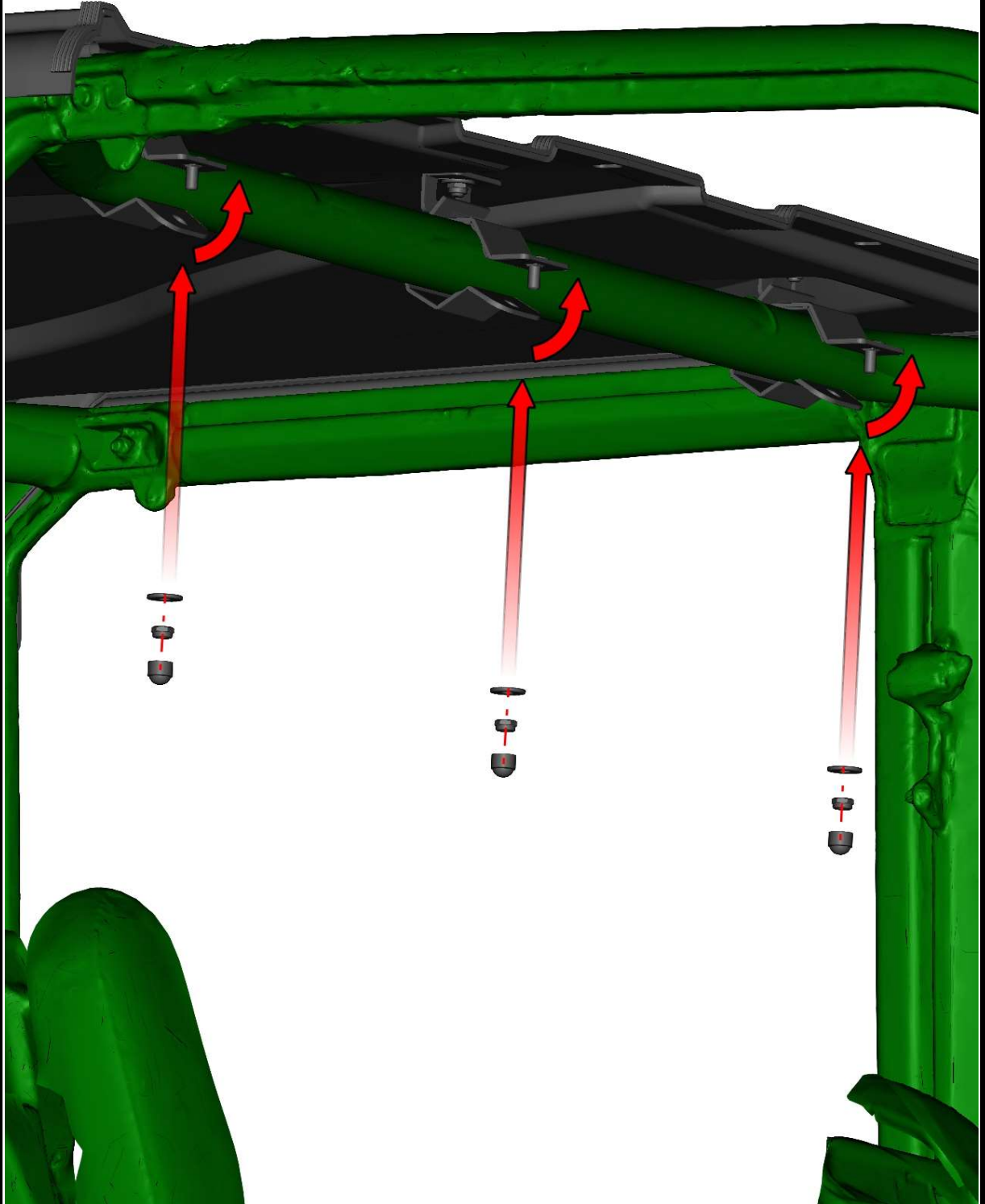

13

FOR ALL TECHNICAL QUESTIONS, PLEASE CALL
DFK AMERICA INC.
(630) 324-8585

Uninstall the front roof panel holders (red circles).

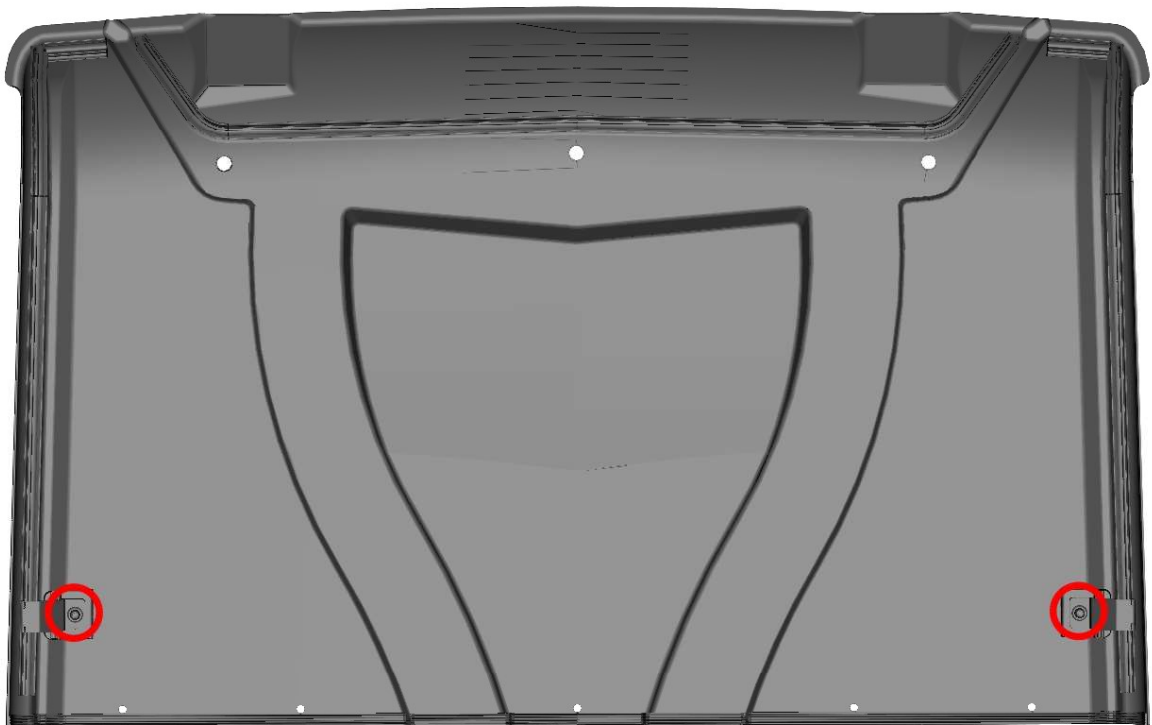

14

Place and adjust the front roof panel onto UVT roll cage.

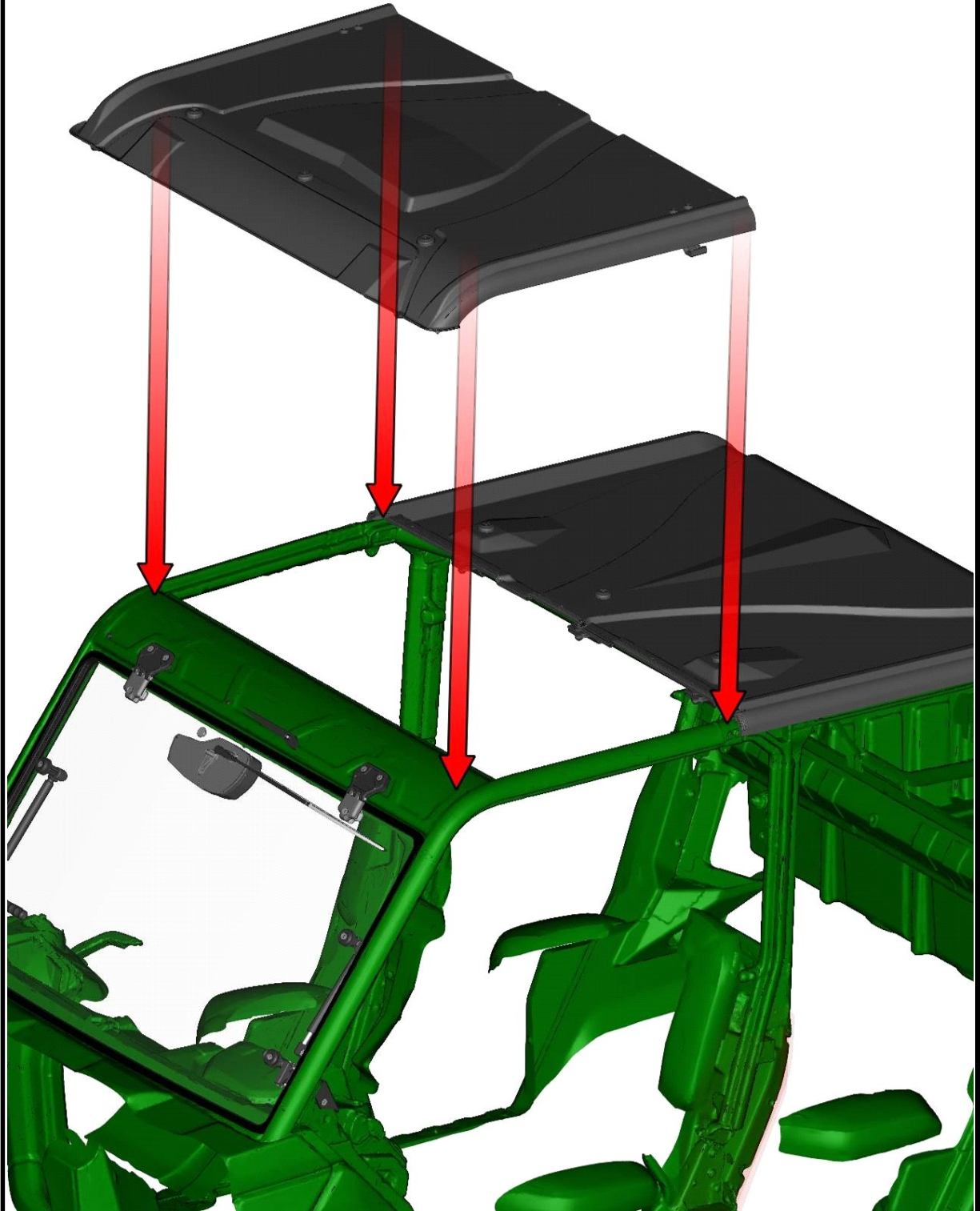

15

FOR ALL TECHNICAL QUESTIONS, PLEASE CALL
DFK AMERICA INC.
(630) 324-8585

Connect the front and rear roof panel together and fix with included fixing assemblies.

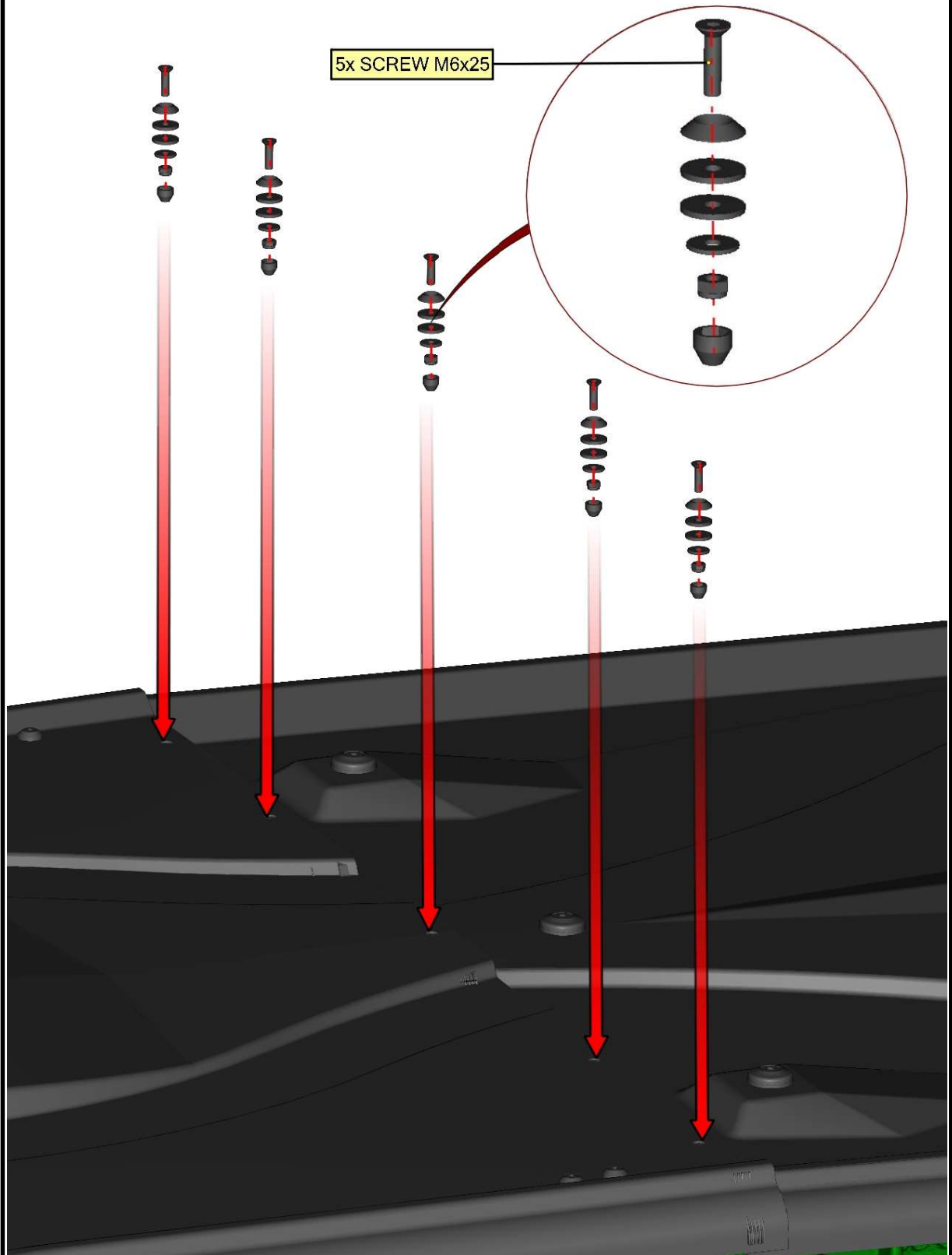

Install the front roof panel holders to the correct position and tighten the screws correctly.

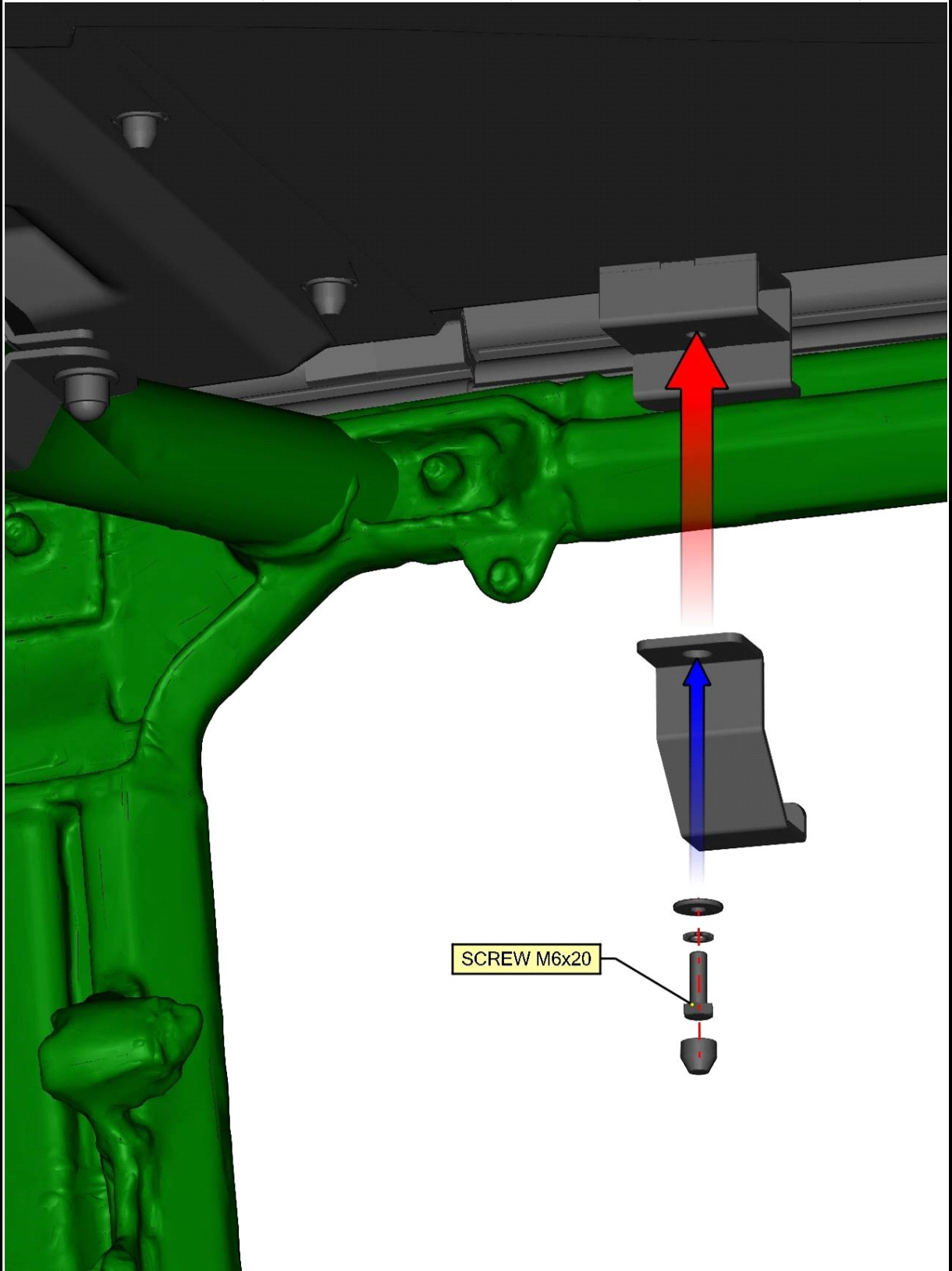

Fix the front roof panel onto UTV roll cage with included fixing assemblies.

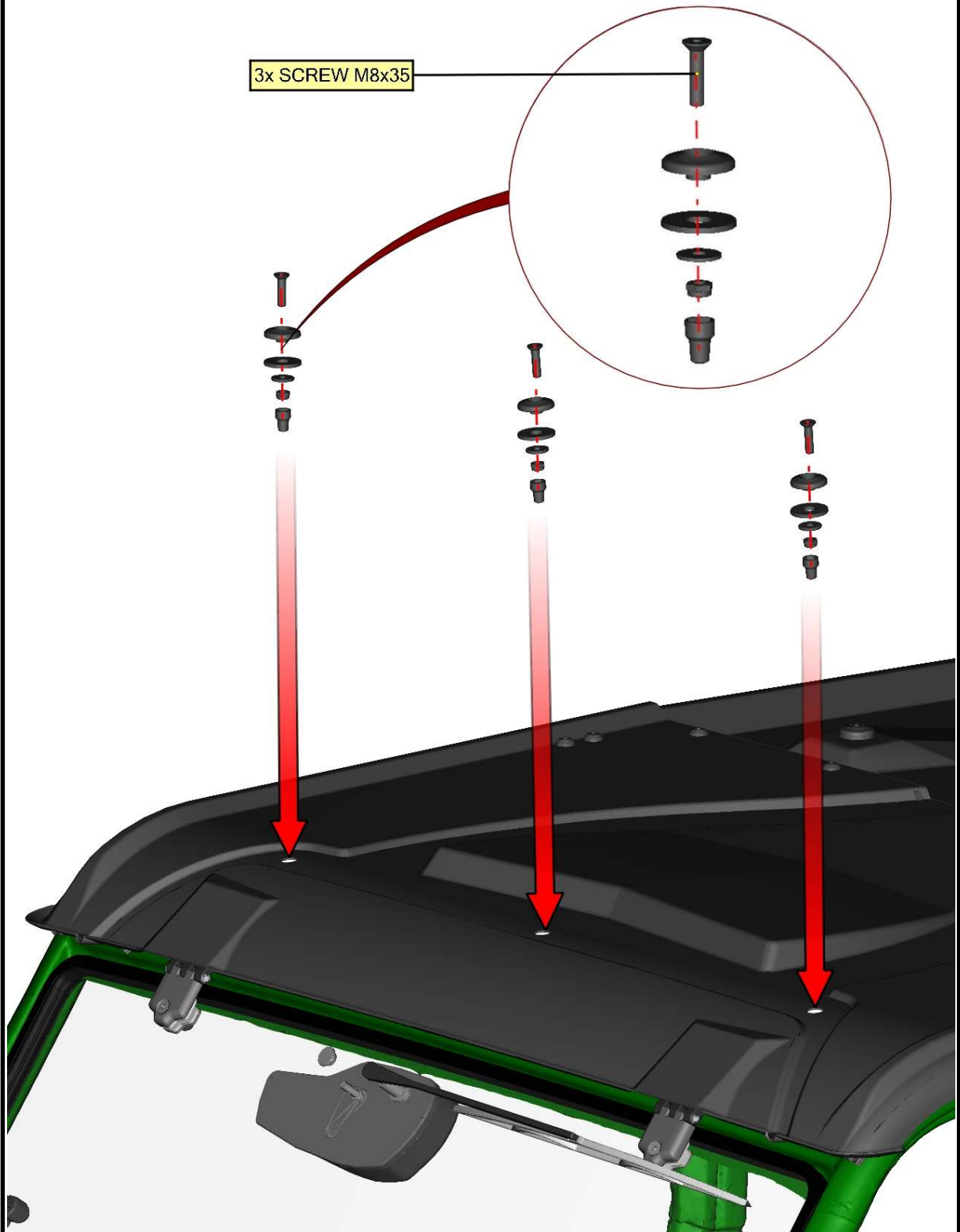

3x SCREW M8x35

REAR PANEL

Losen the rear panel holders screws and turn the rear panel holders.

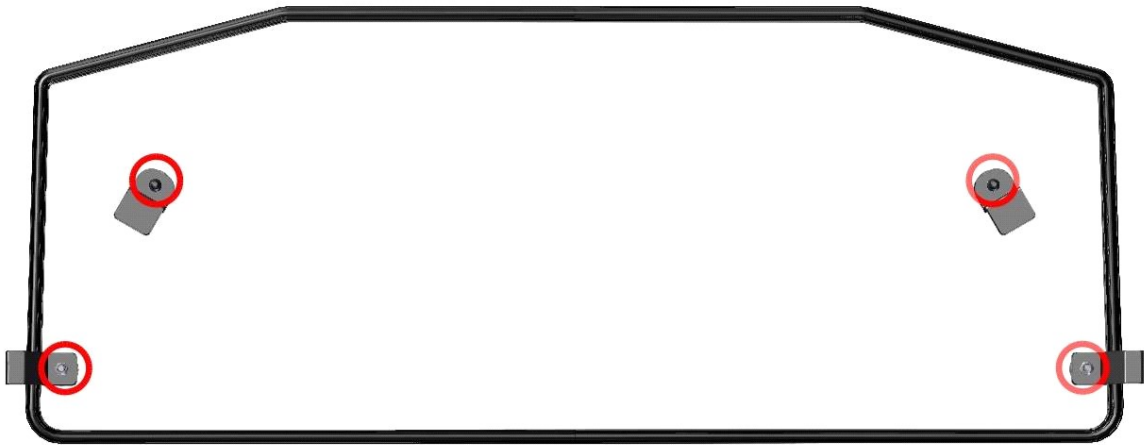

19

Place and adjust the rear panel to the best position onto UTV roll cage.

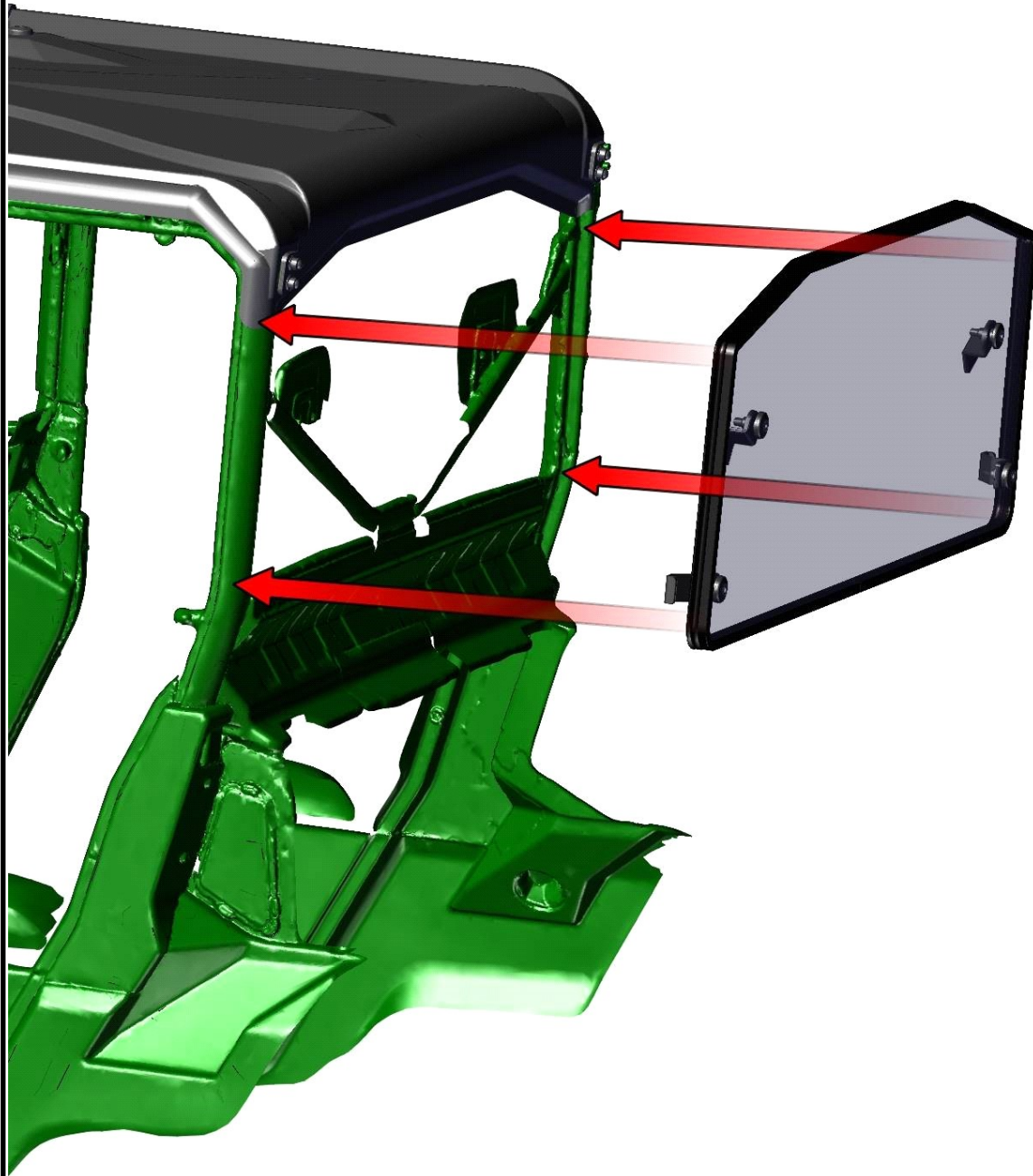

Turn the rear panel holders to the correct position and tighten the screws correctly.

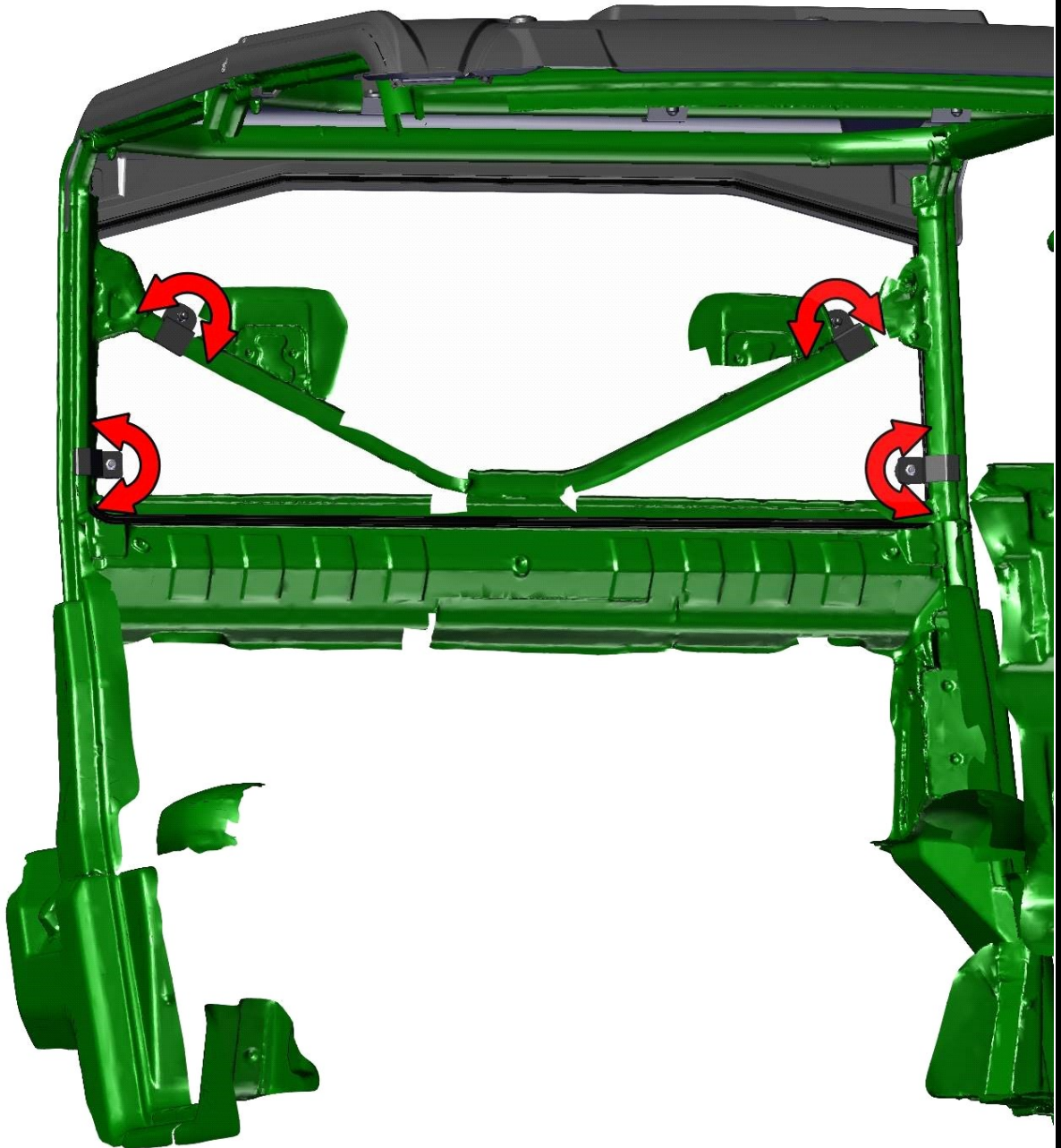

21

LEFT REAR DOOR + RIGHT REAR DOOR

Install the left rear door hinges and fix onto UTV roll cage with included fixing assemblies.

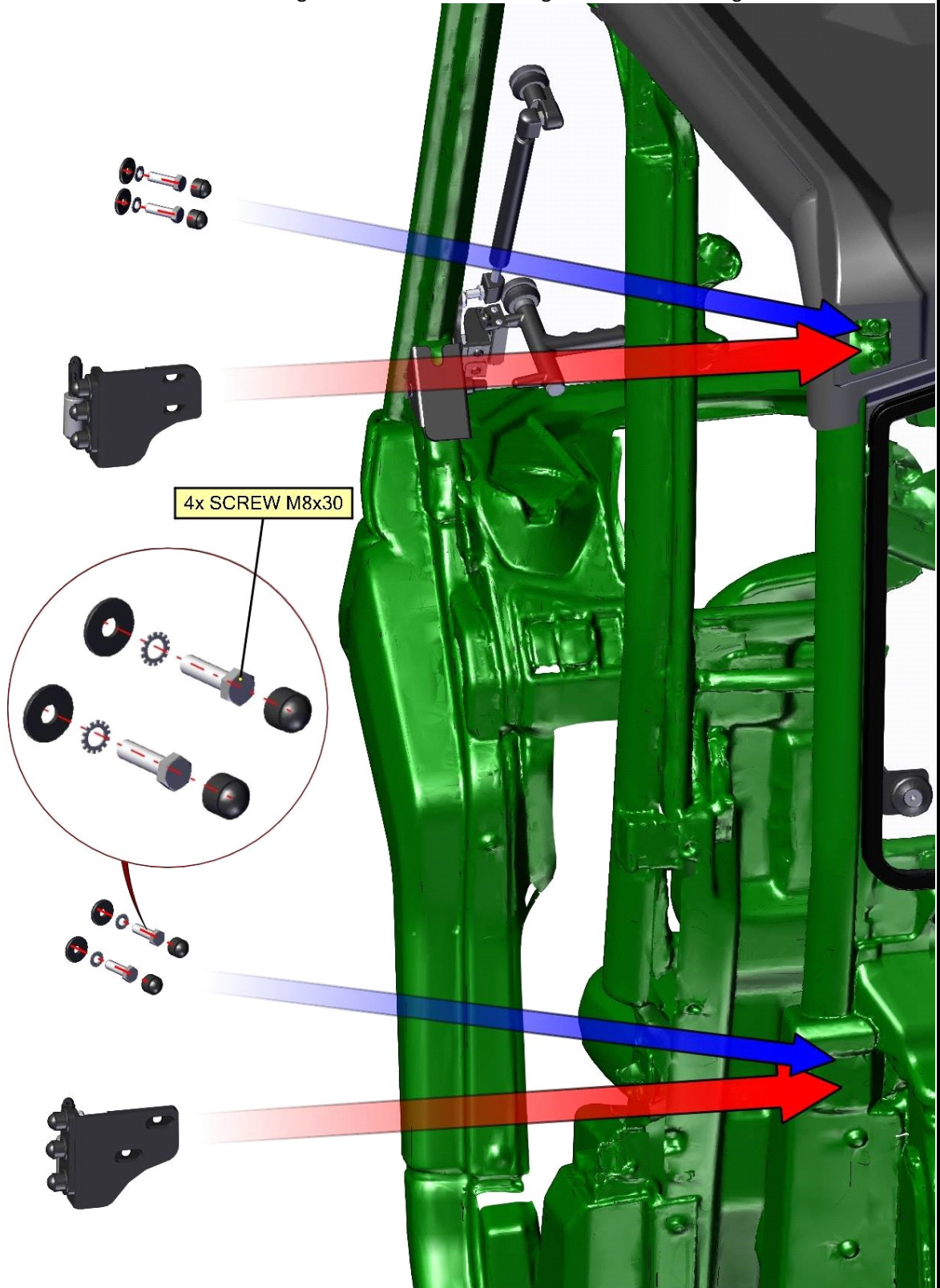

Install the door stop assembly into the rear left door stop holder. Fix by included fixing assemblies.

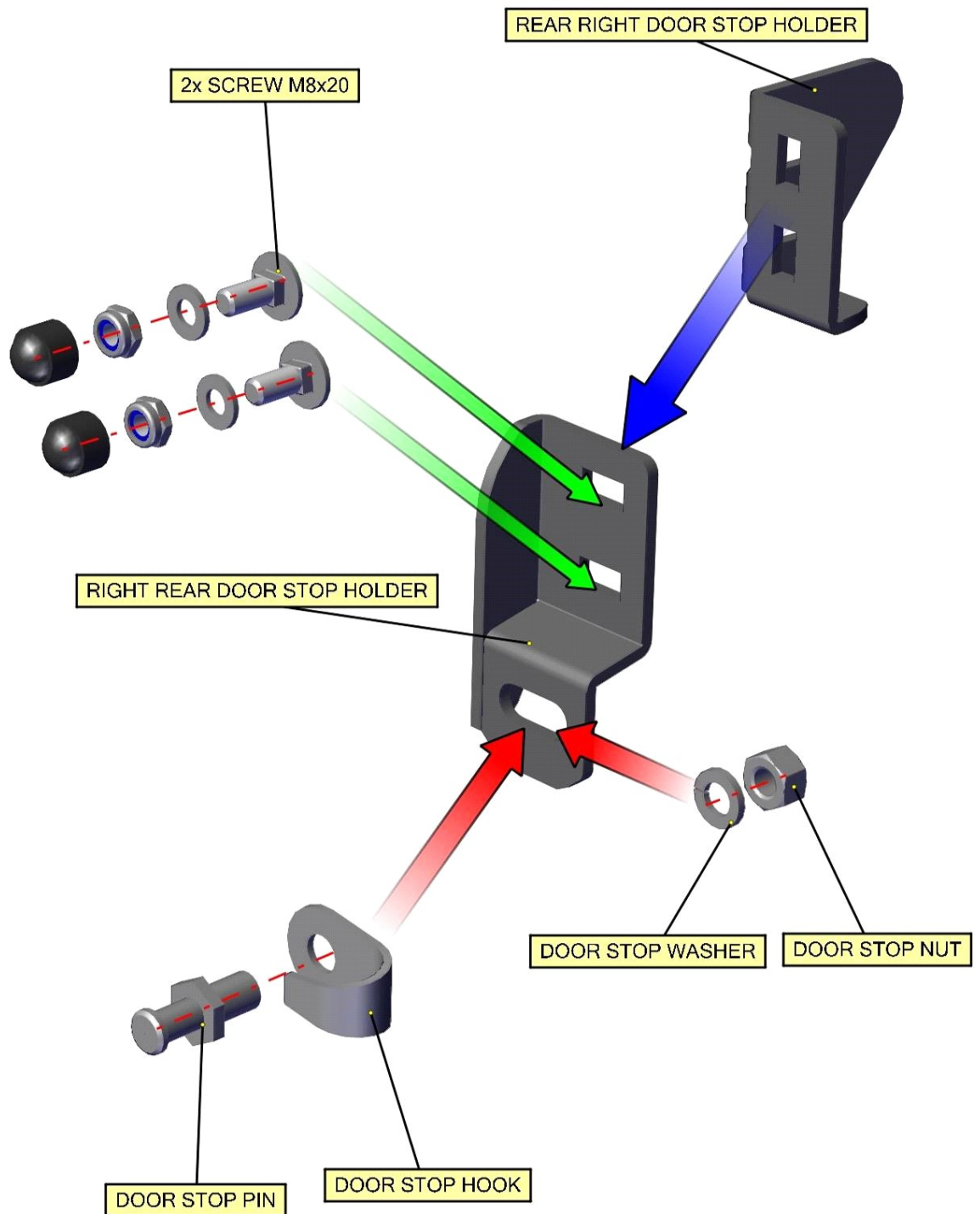

Place the left rear door stop assembly onto the UTV roll cage.

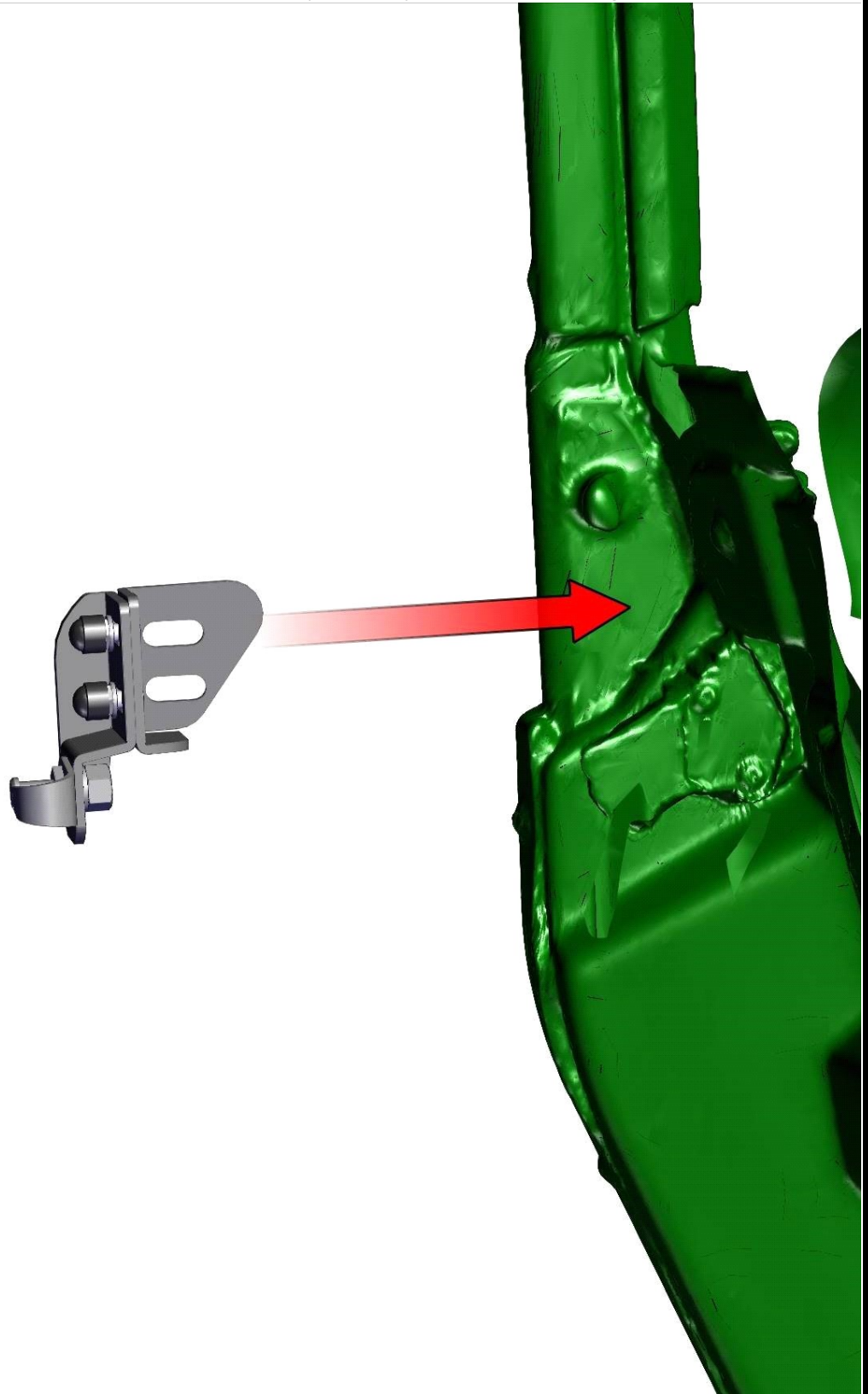

24

Fix the rear left door stop assembly with included screws, washers and covers.

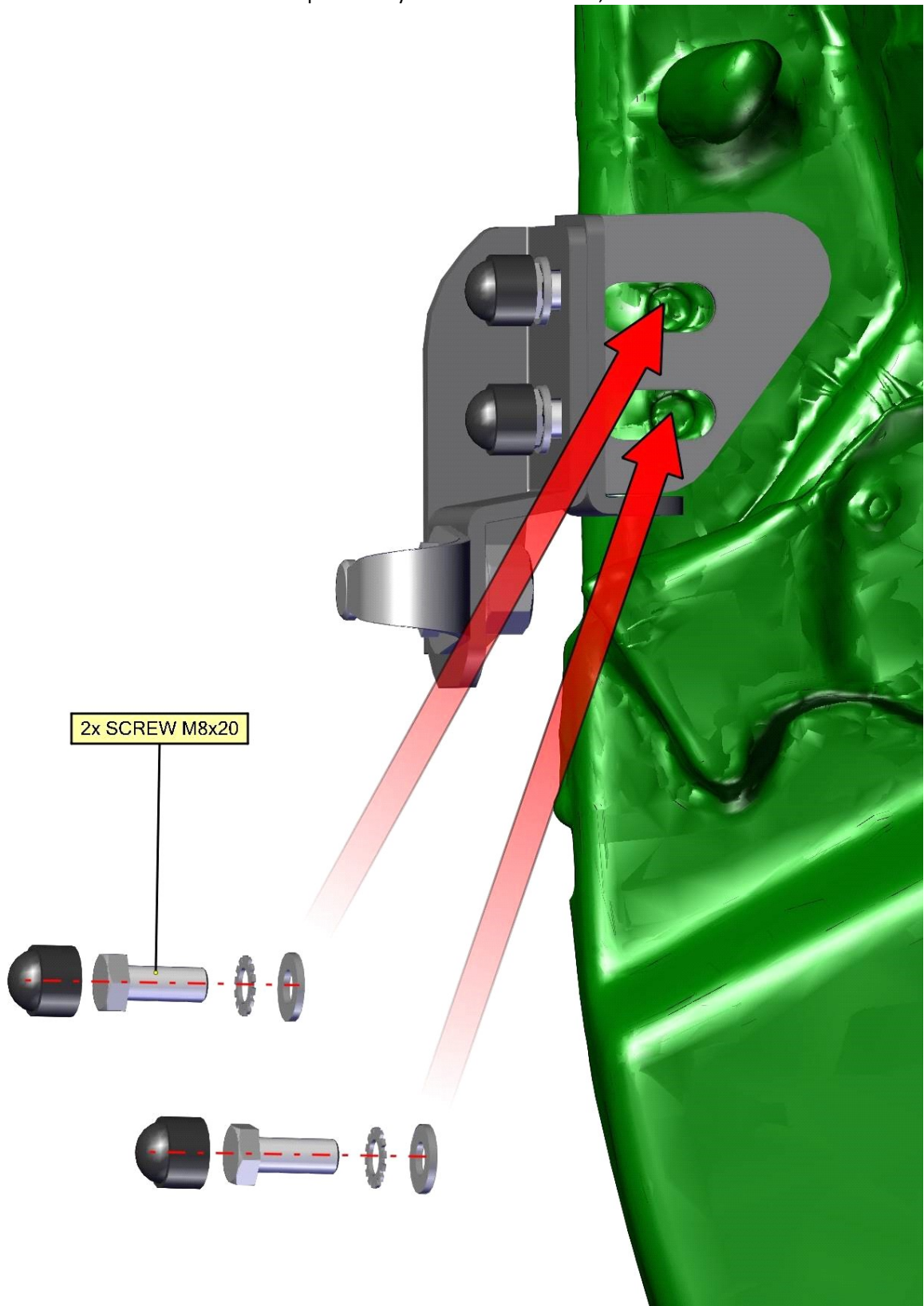

Place the left rear door onto the hinges. If necessary install the washers 10 onto the hinges pins.

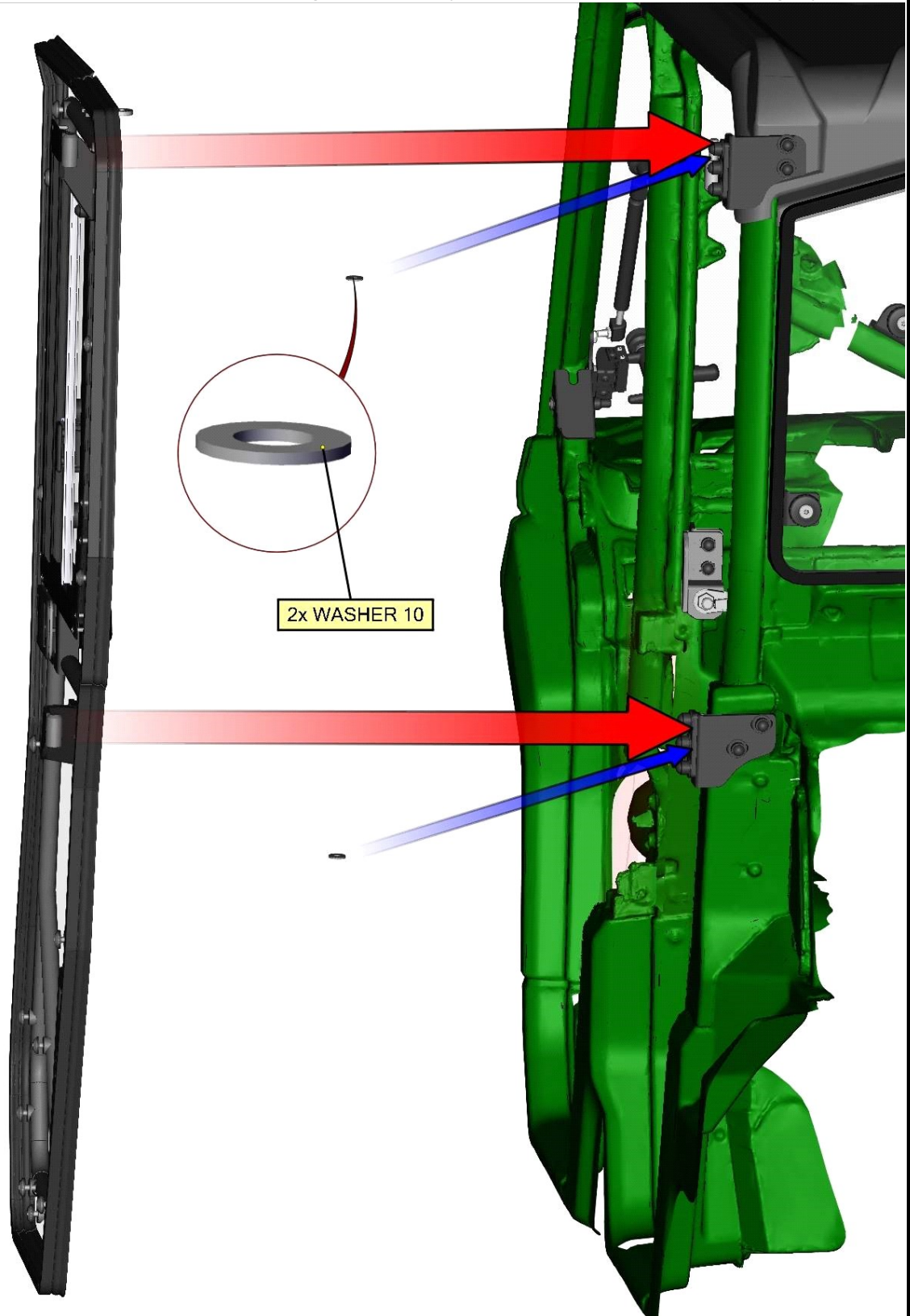

If necessary loosen the hinge screws (red circles) and set the door to the best position.

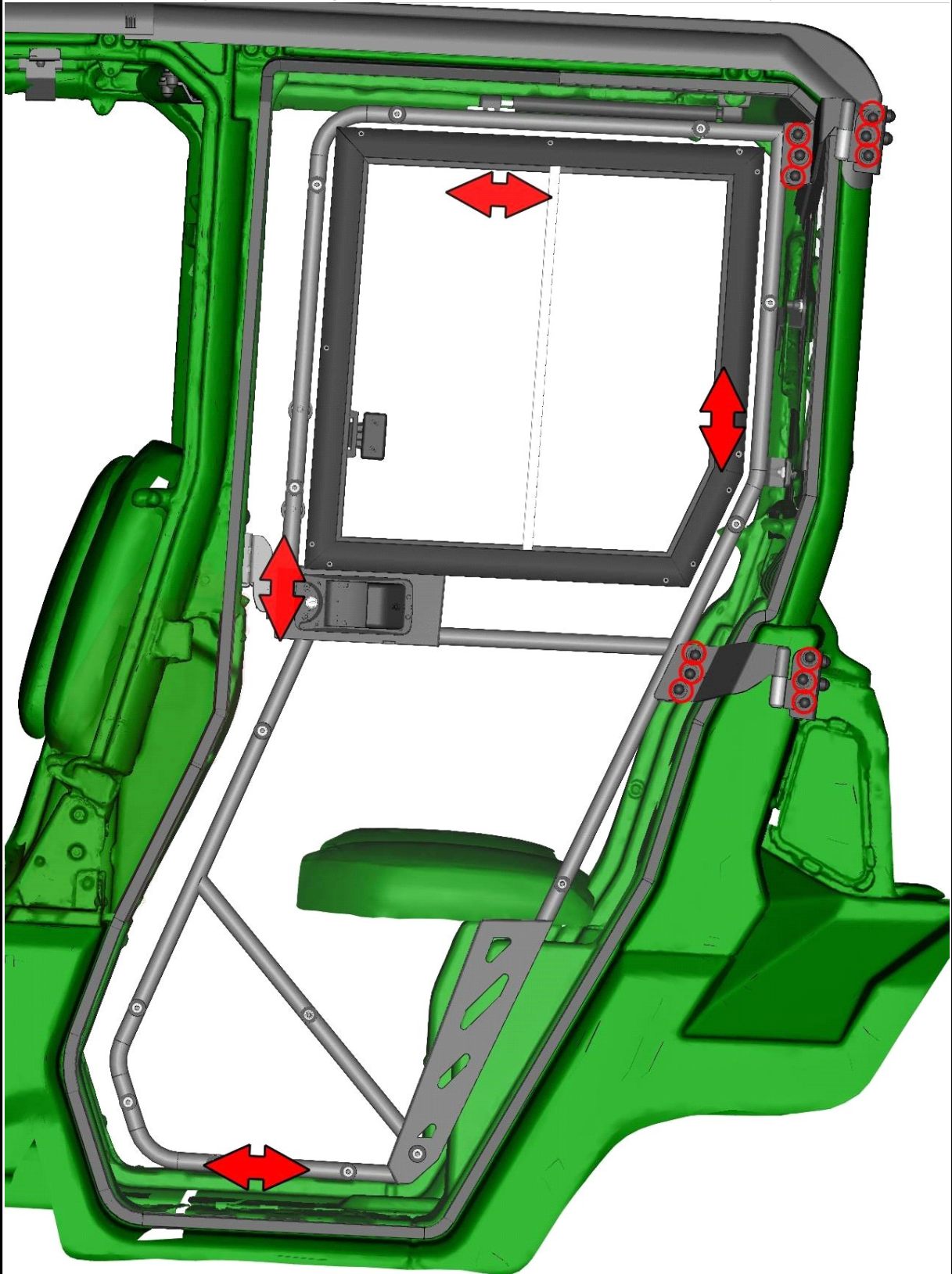

Adjust the rear left door stop assembly into the best position and tighten the screws hard.

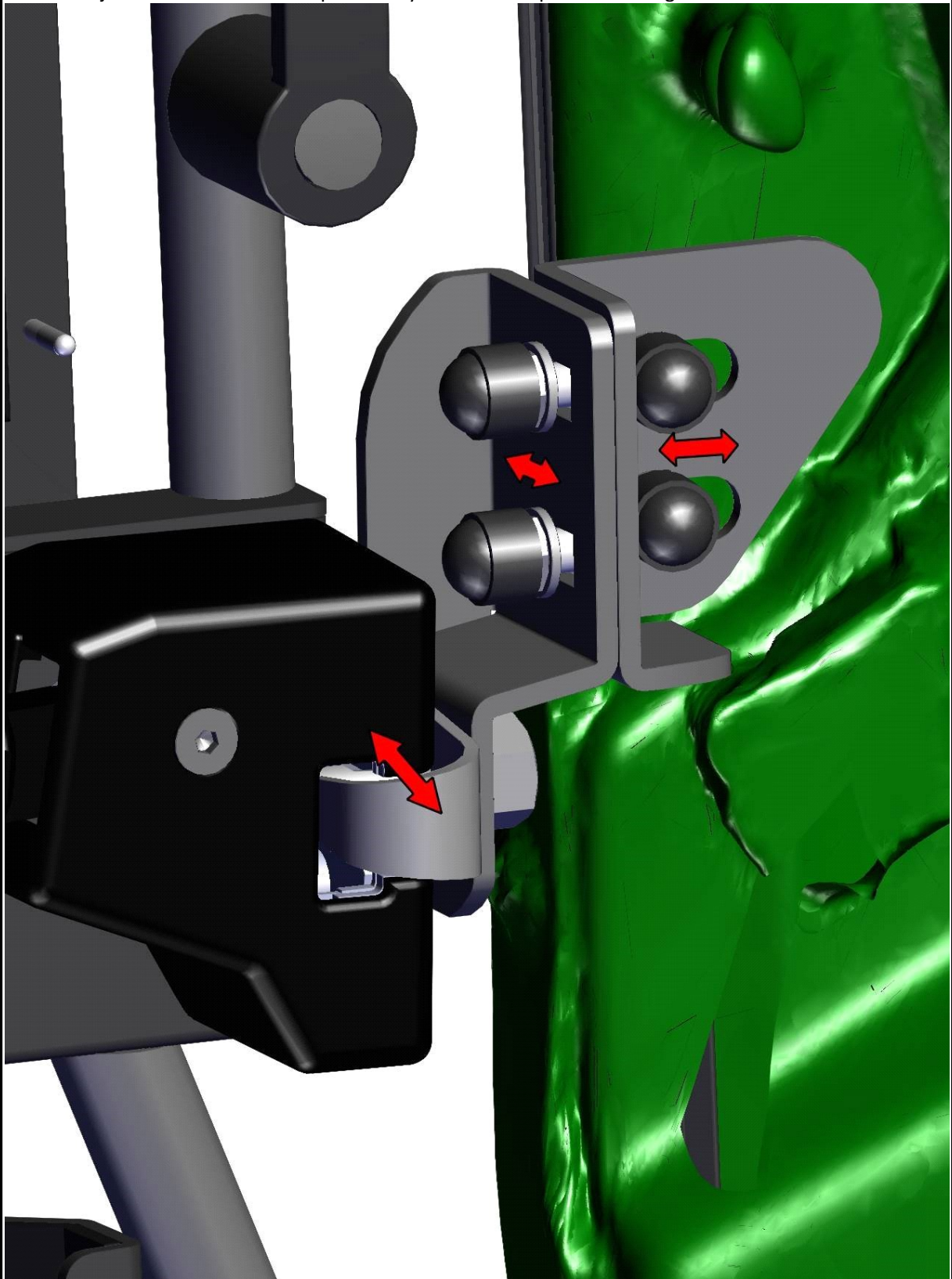

Install the gas spring holder onto UTV roll cage and fix with included fixing assembly.

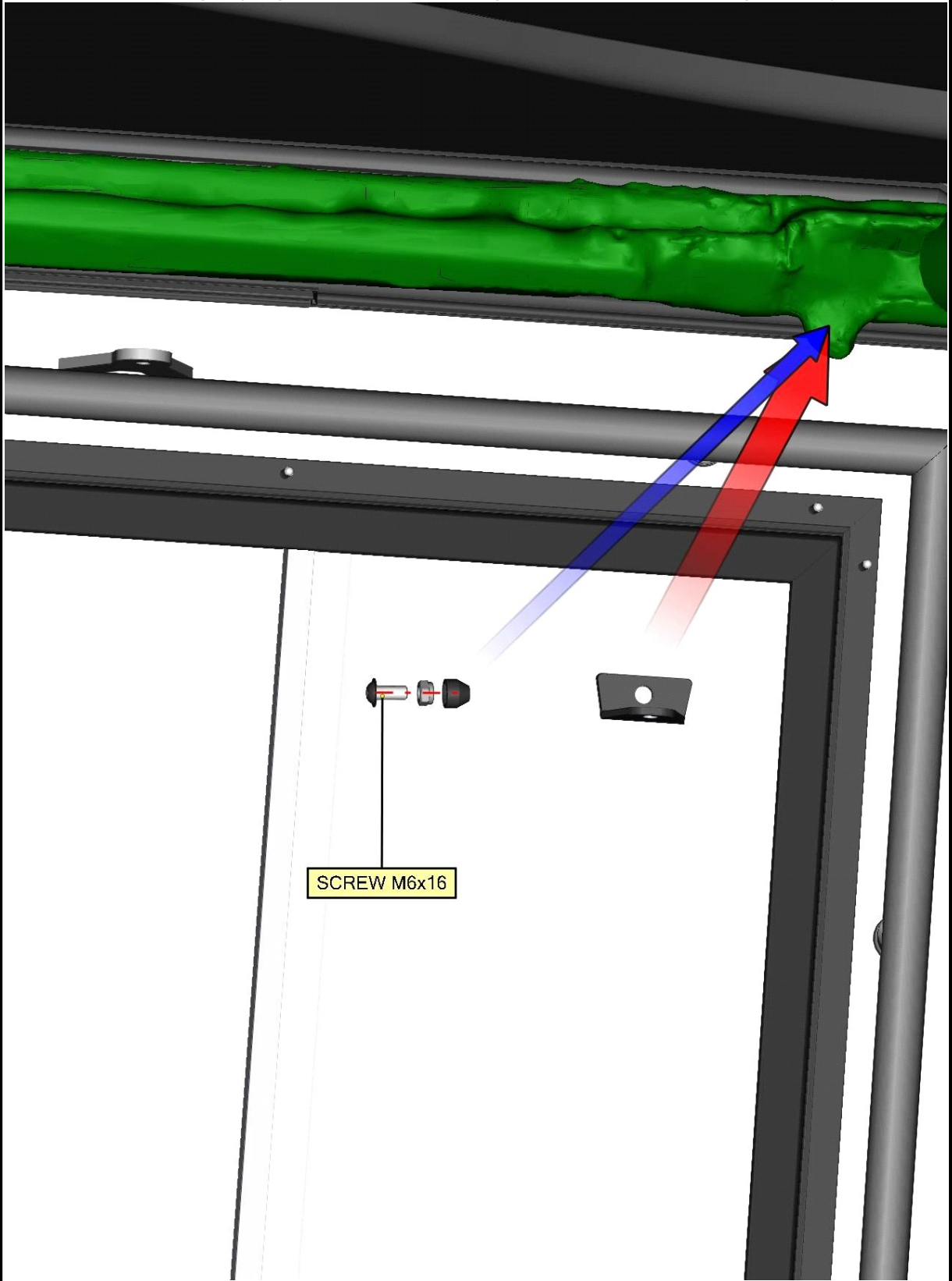

Install the gas spring pins and fix with included washers, screws and covers.

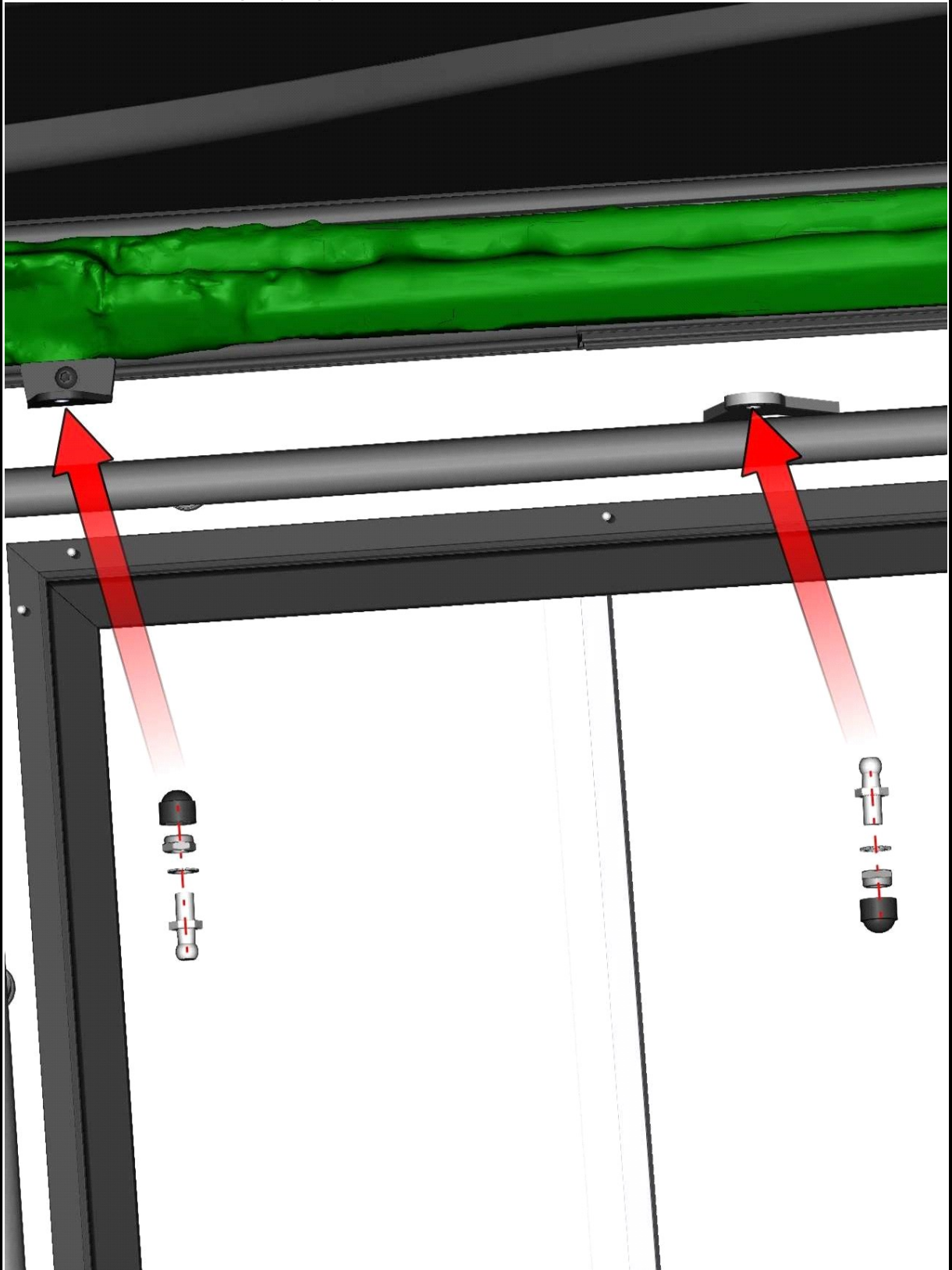

30

FOR ALL TECHNICAL QUESTIONS, PLEASE CALL
DFK AMERICA INC.
(630) 324-8585

Install the gas spring onto the gas spring pins.

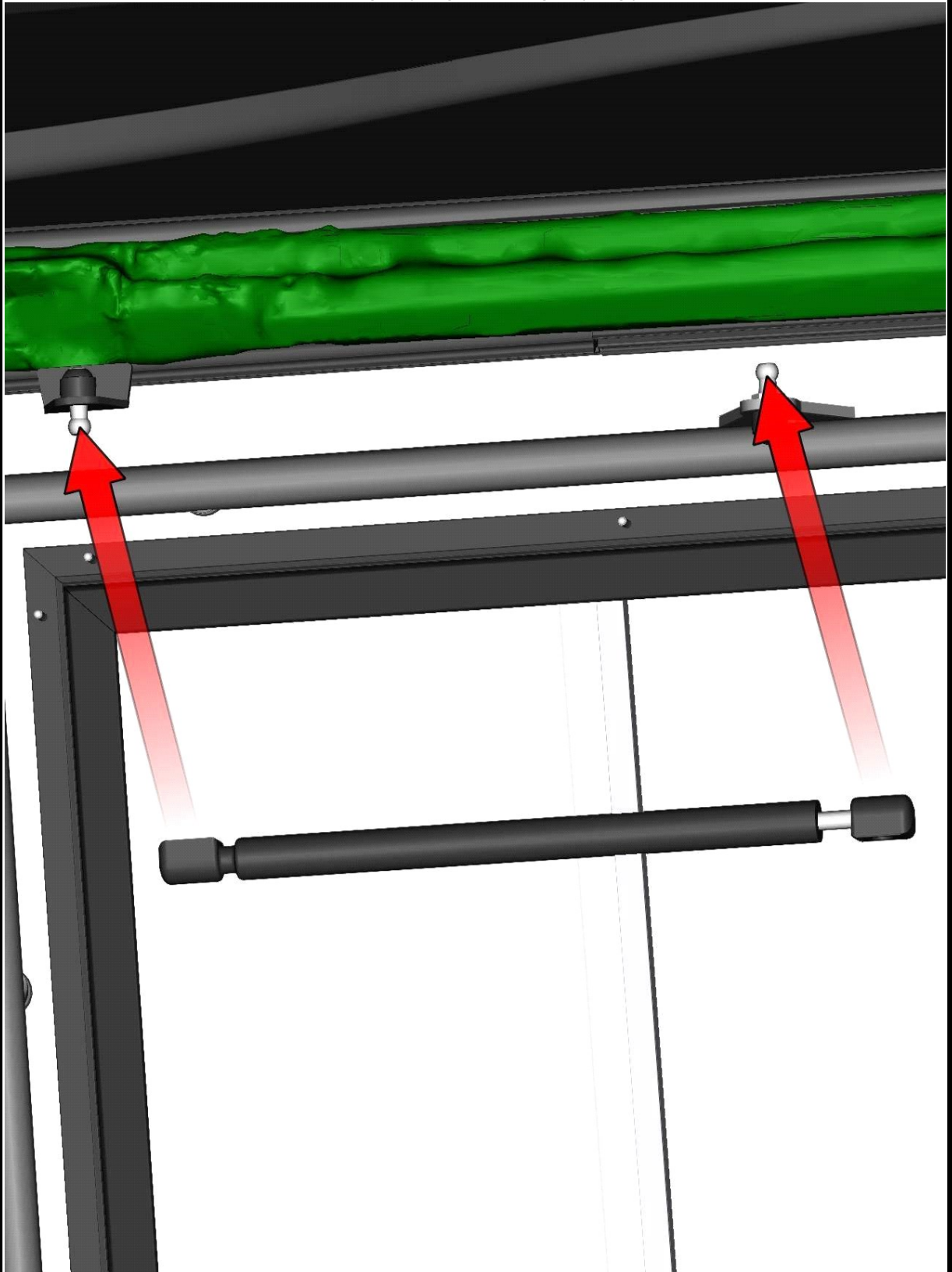

31

FOR ALL TECHNICAL QUESTIONS, PLEASE CALL
DFK AMERICA INC.
(630) 324-8585

Repeat previous steps with right rear door.

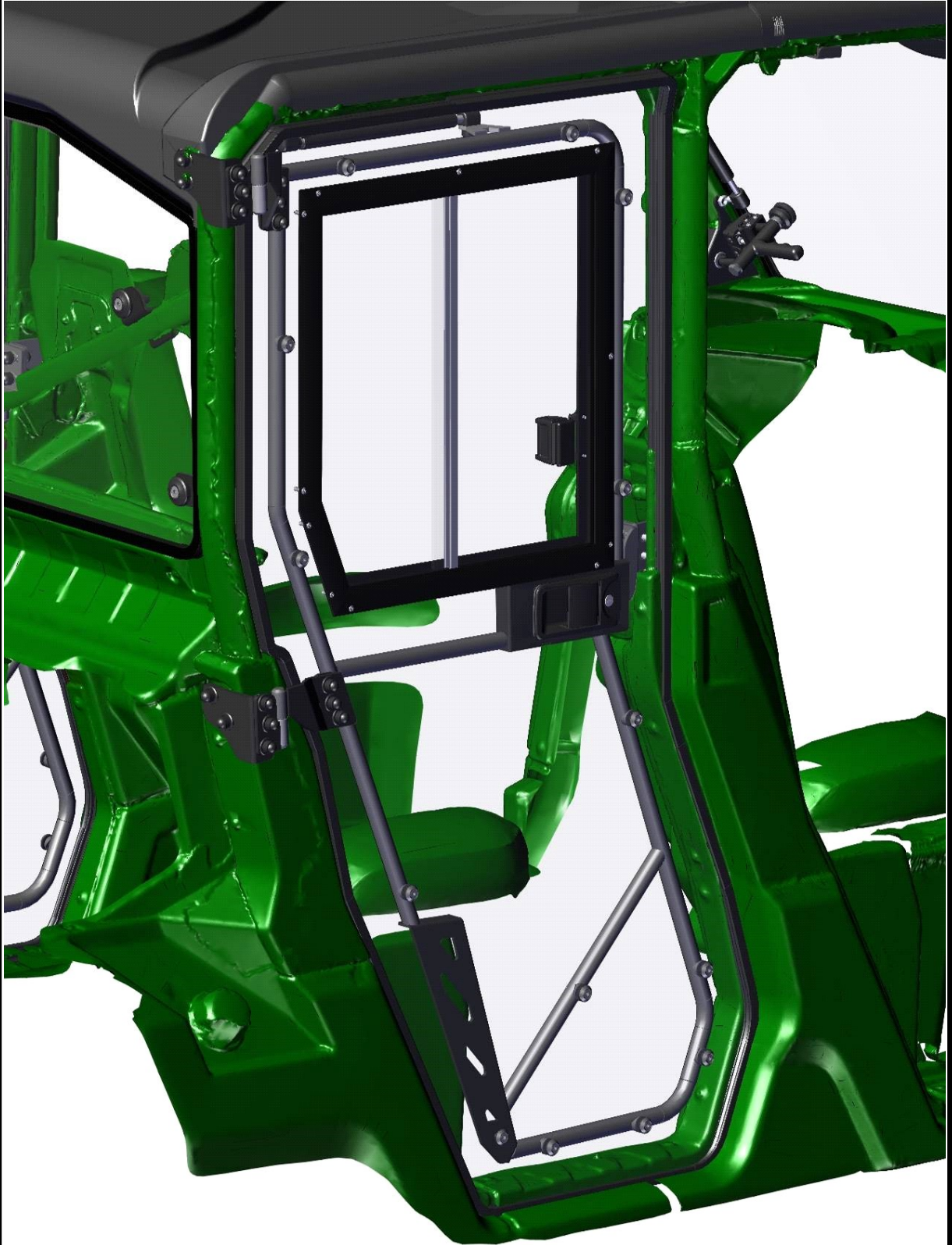

LEFT FRONT DOOR + RIGHT FRONT DOOR

Unscrew the cover fixing screws (red circles) and uninstall the plastic cover.



Save the fixing assemblies for later usage.



FOR ALL TECHNICAL QUESTIONS, PLEASE CALL
DFK AMERICA INC.
(630) 324-8585

Remove the plastic cover

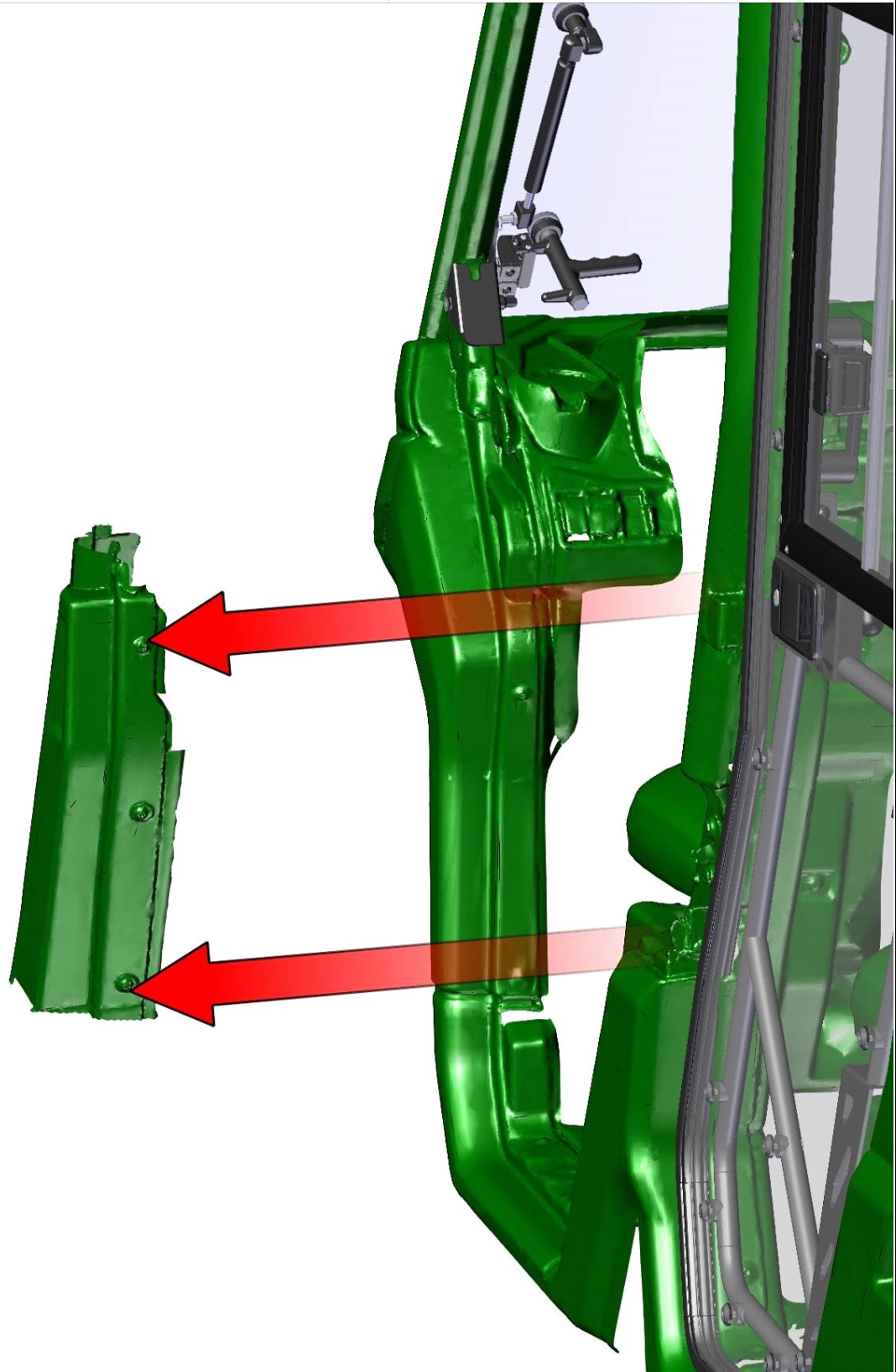

Install the bottom left front door hinge and fix onto UTV roll cage with included fixing assemblies.

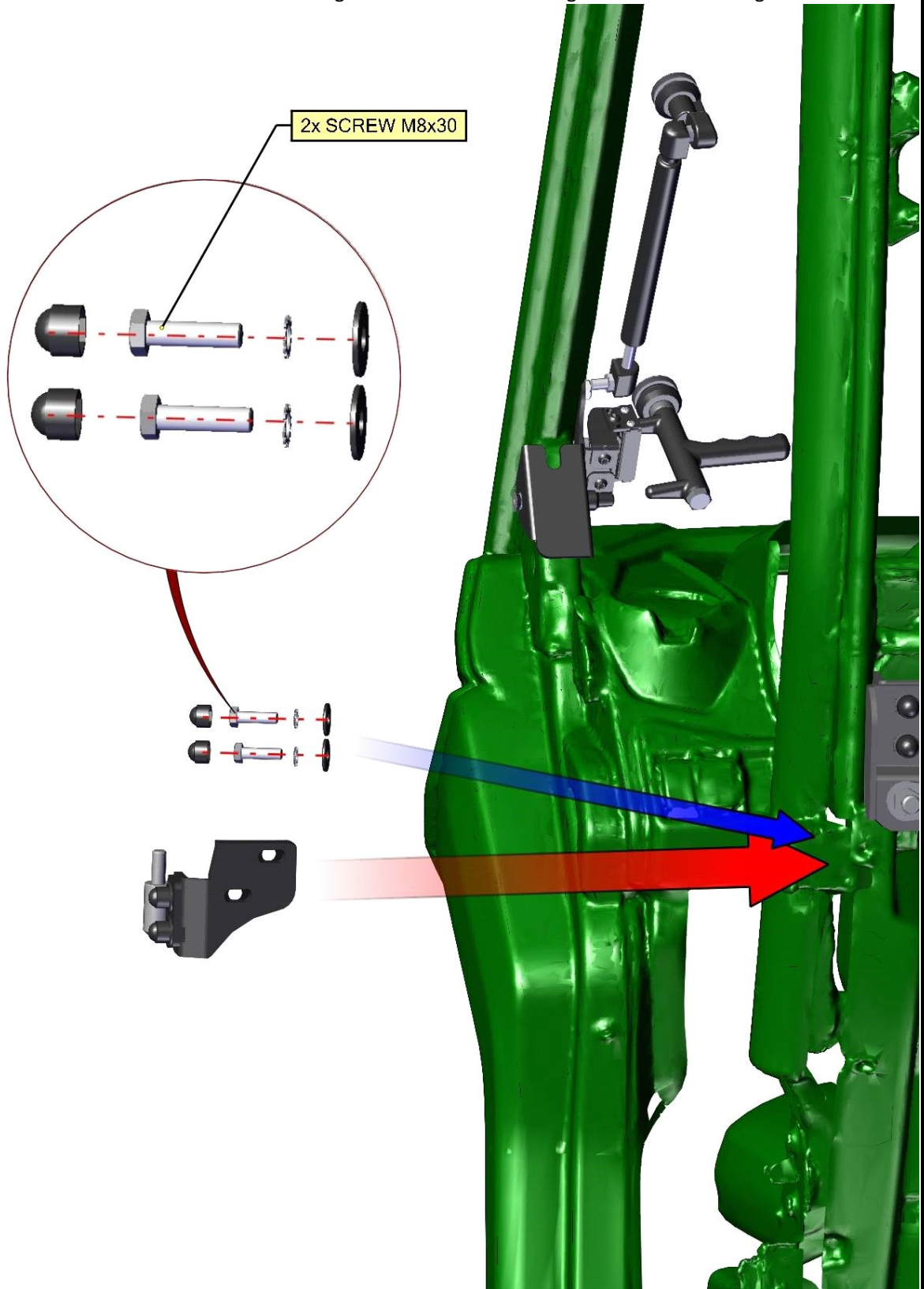

FOR ALL TECHNICAL QUESTIONS, PLEASE CALL
DFK AMERICA INC.
(630) 324-8585

Remove the hinge cover (red rectangle)



Place the plastic cover back to the correct position and fix with original fixing assemblies.

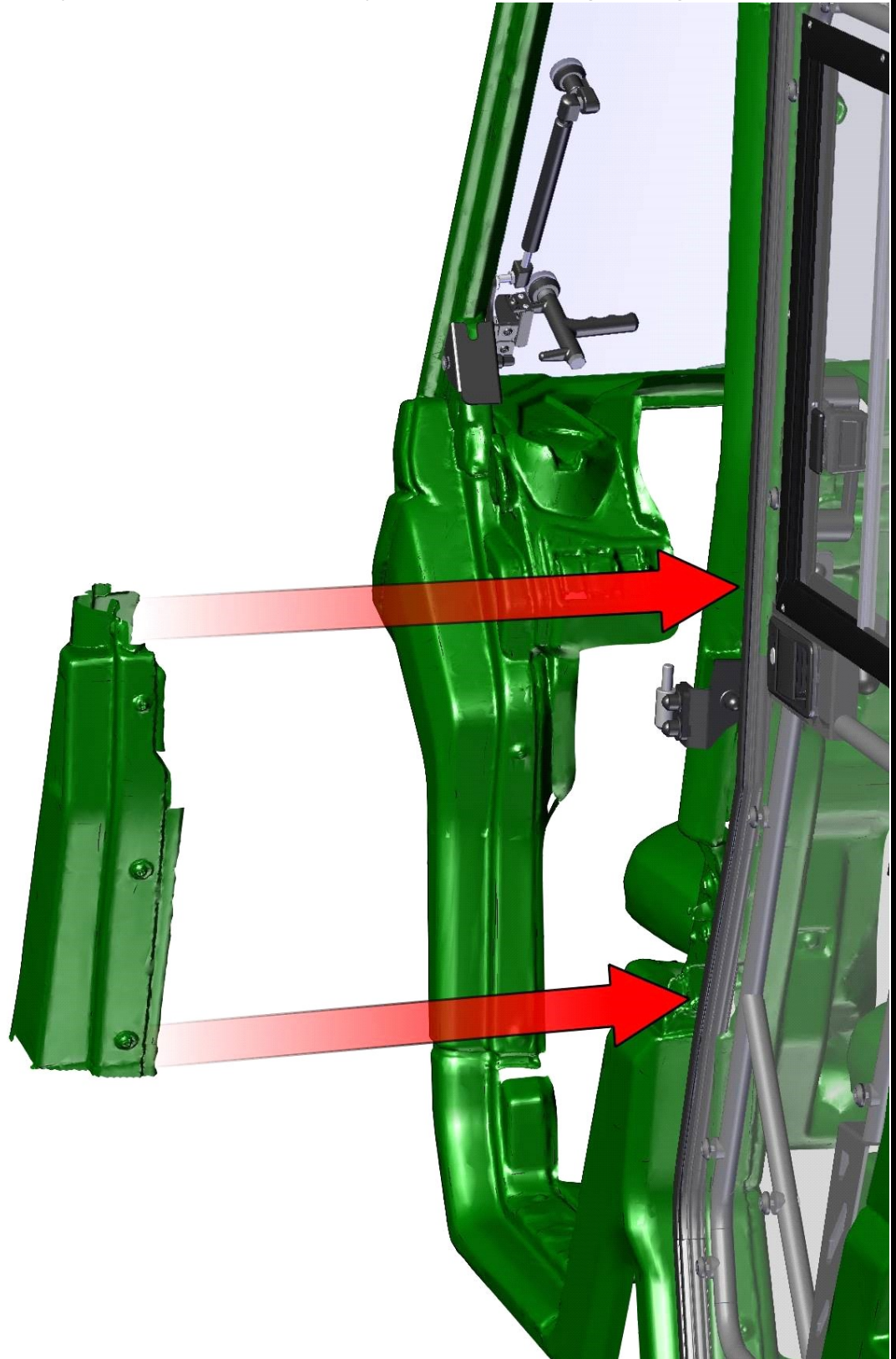

Install the upper left front door hinge and fix onto UTV roll cage with included fixing assemblies.

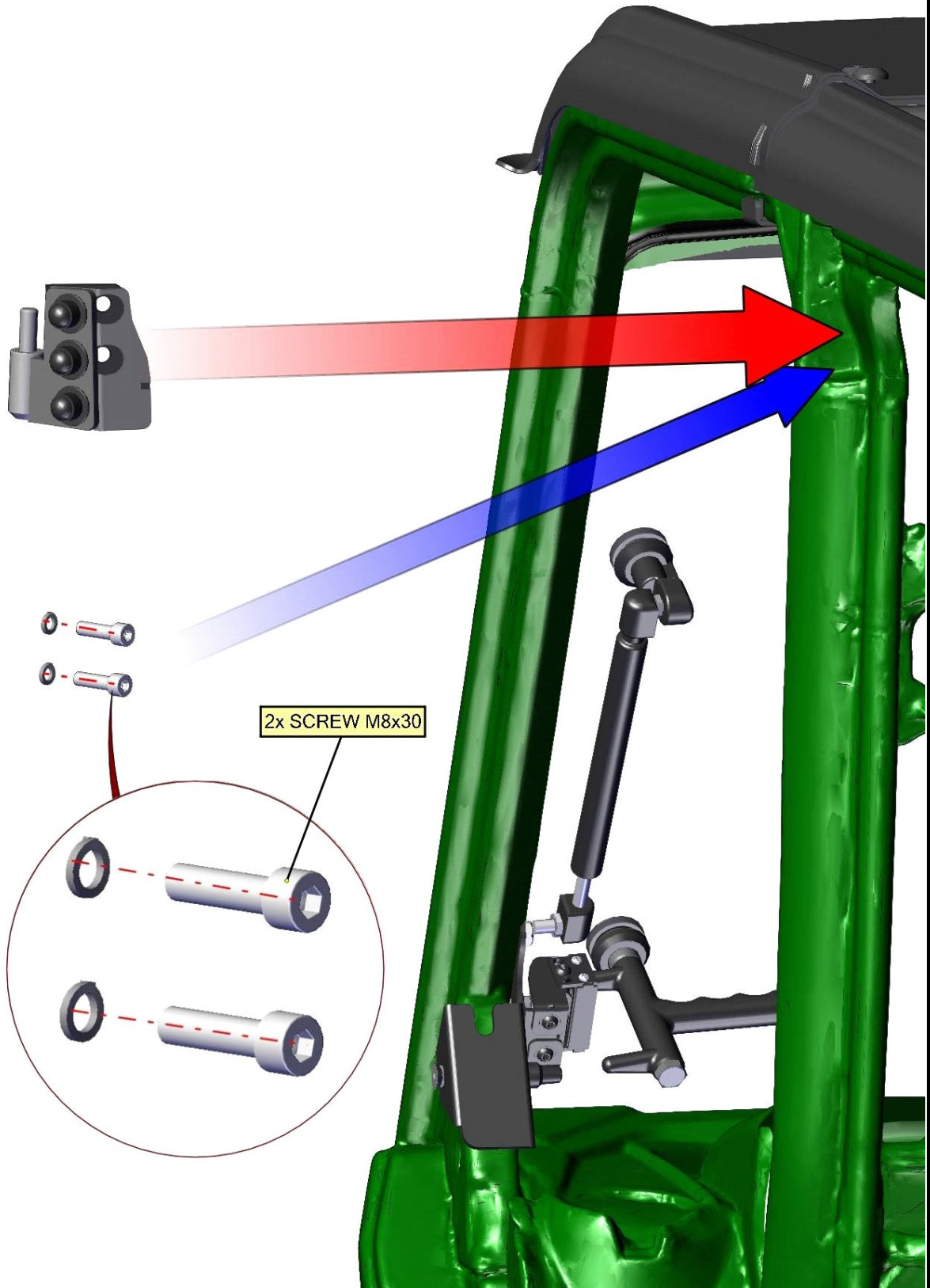

38

FOR ALL TECHNICAL QUESTIONS, PLEASE CALL
DFK AMERICA INC.
(630) 324-8585

Install the door stop assembly into the front left door stop holder. Fix with included fixing assemblies.

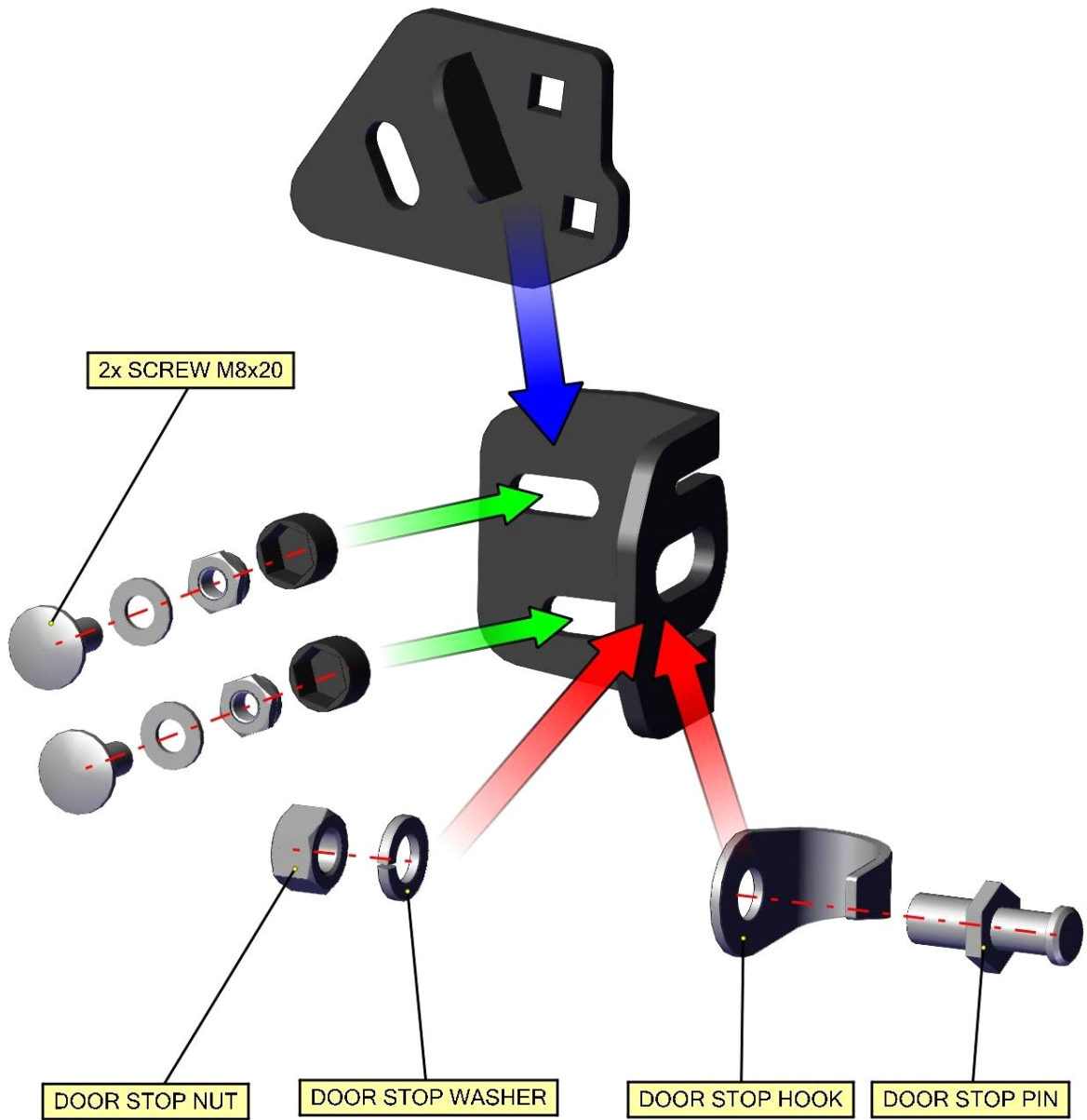

Place the left front door stop assembly onto the left front console and fix with included fixing assemblies.

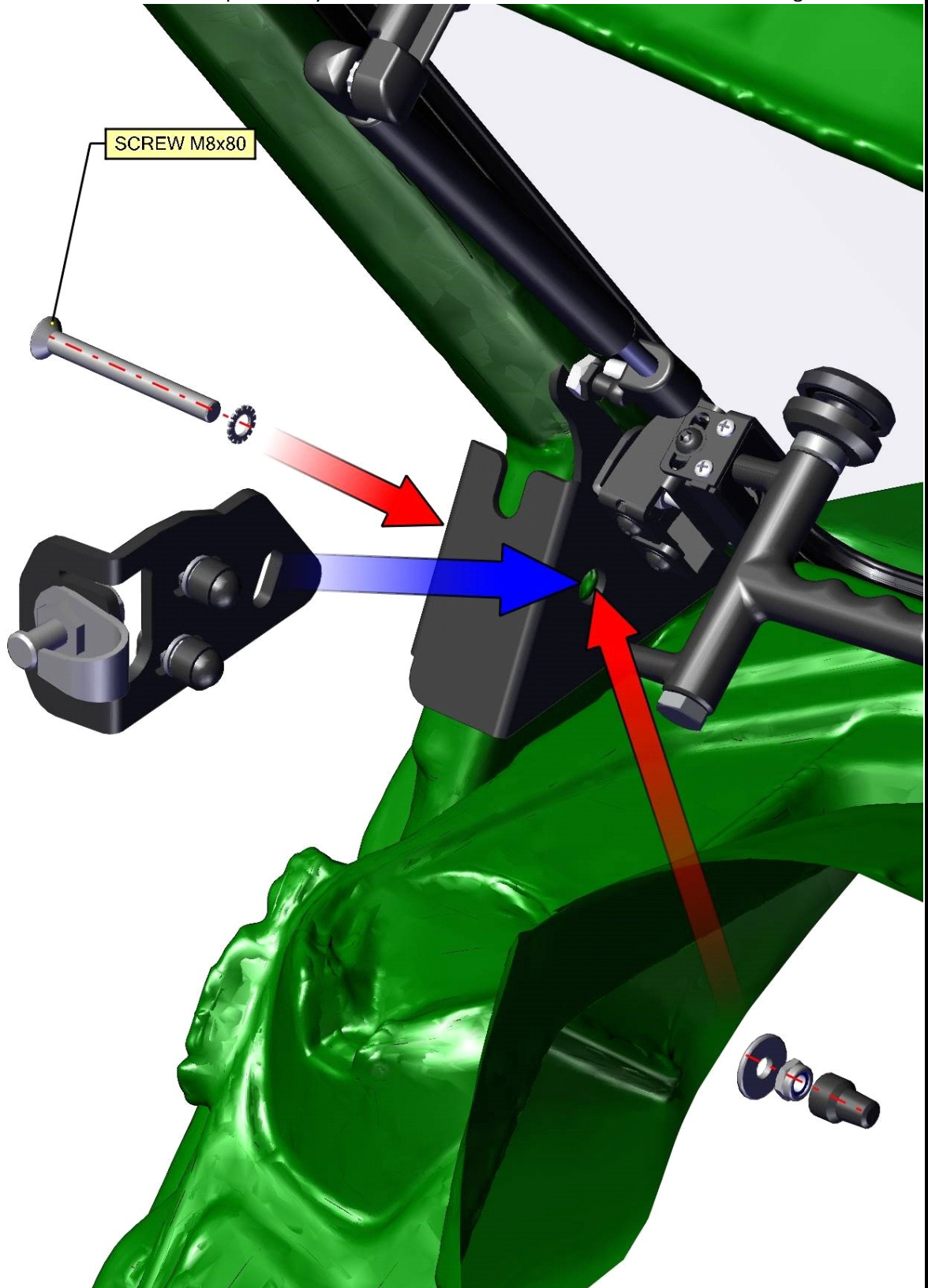

FOR ALL TECHNICAL QUESTIONS, PLEASE CALL
DFK AMERICA INC.
(630) 324-8585

Place the left front door onto the hinges.

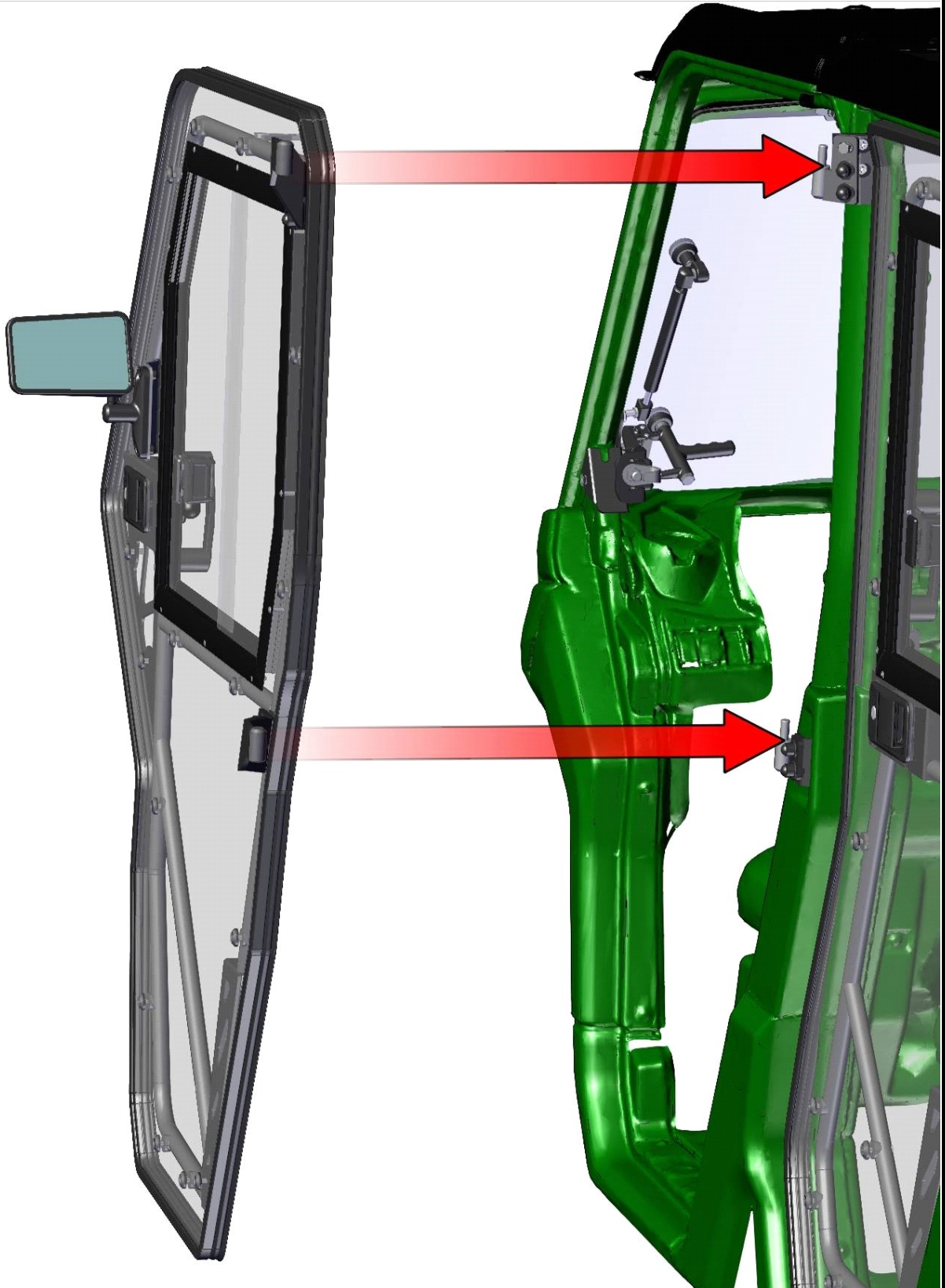

If necessary loosen the hinge screws (red circles) and set the door to the best position.

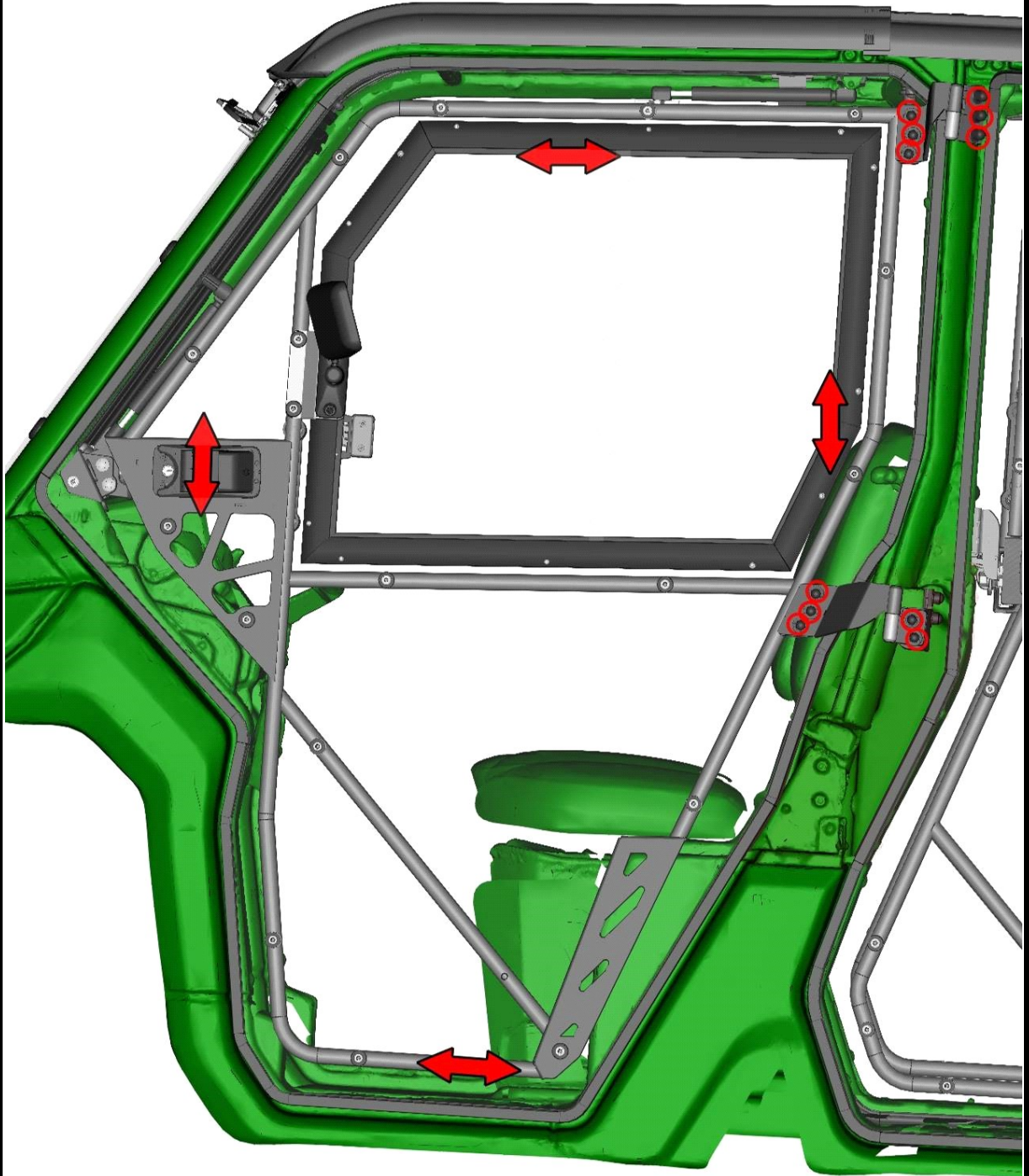

42

FOR ALL TECHNICAL QUESTIONS, PLEASE CALL
DFK AMERICA INC.
(630) 324-8585

Adjust the left front door stop assembly into the best position and tighten the screws hard.



43

Install the gas spring holder onto UTV roll cage and fix with included fixing assembly.

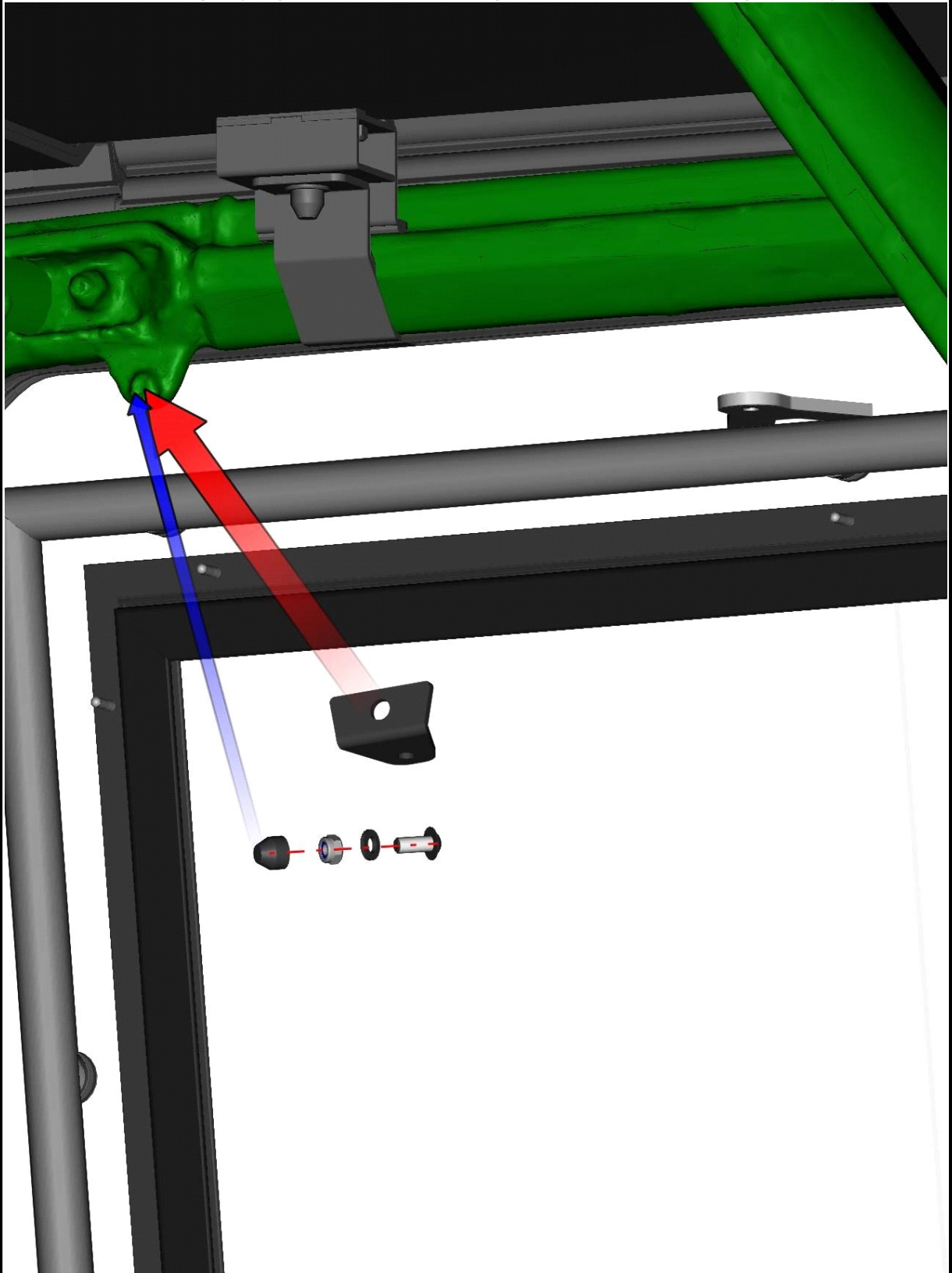

Install the gas spring pins onto gas spring holders a fix with included washers, nuts and covers.

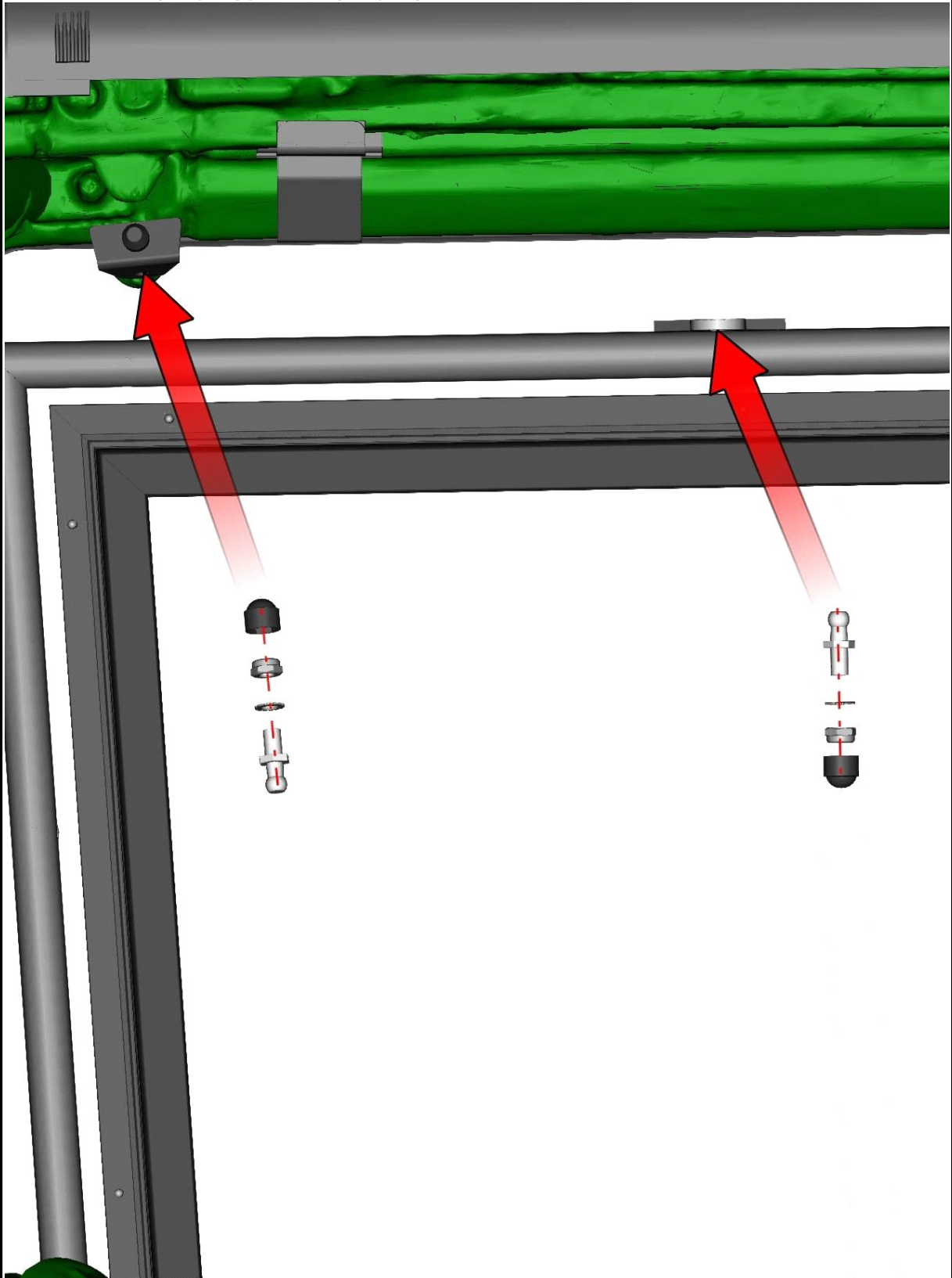

45

FOR ALL TECHNICAL QUESTIONS, PLEASE CALL
DFK AMERICA INC.
(630) 324-8585

Install the the gas spring onto the gas spring pins.

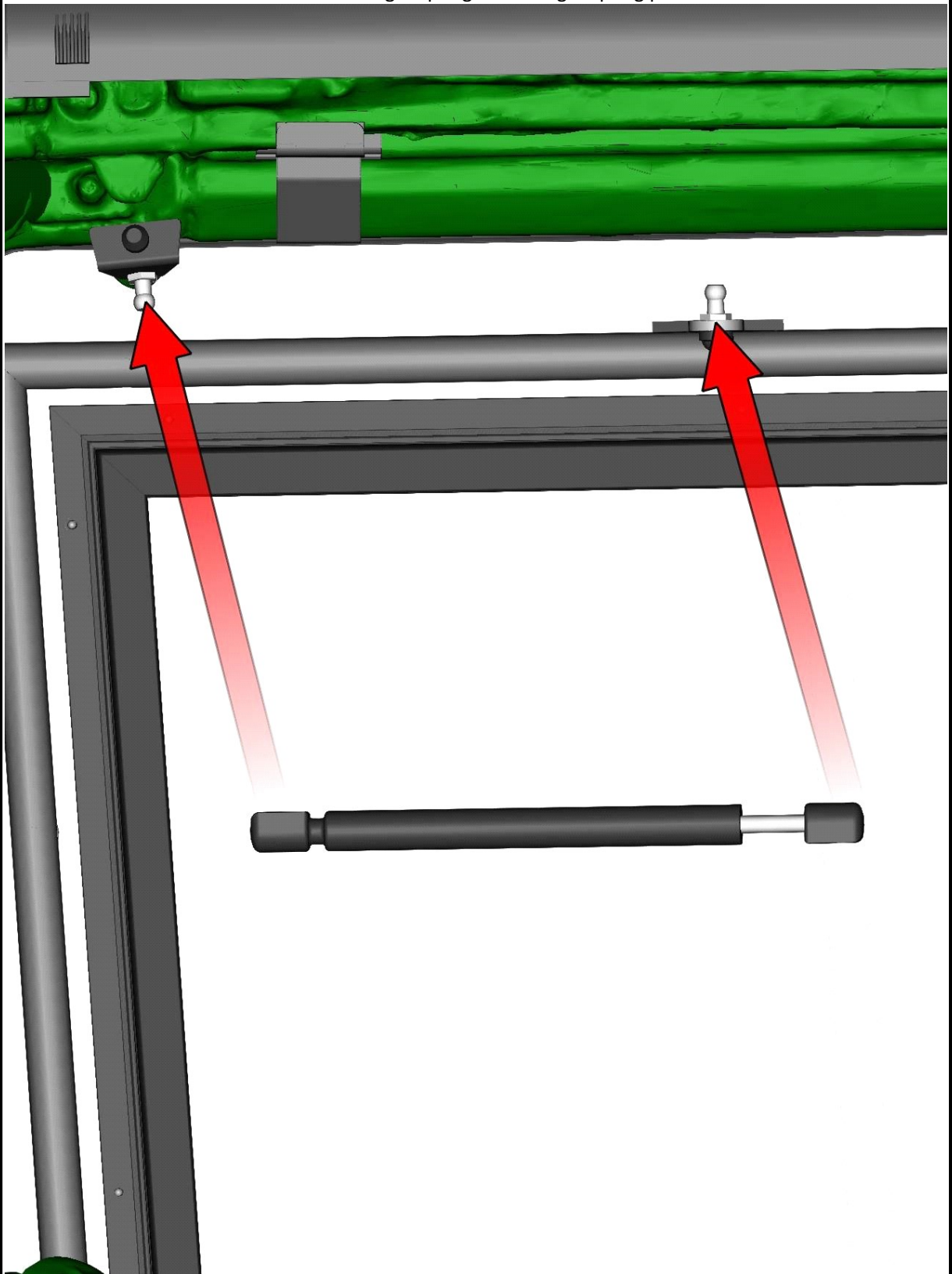

Repeat previous steps with right front door.



47

FOR ALL TECHNICAL QUESTIONS, PLEASE CALL
DFK AMERICA INC.
(630) 324-8585

ELECTROINSTALLATION
WIPER/WASHER

Install the washer tank holder to the rear part of vehicle (red circle).



Carefully uninstall the central tunnel cover.



FOR ALL TECHNICAL QUESTIONS, PLEASE CALL
DFK AMERICA INC.
(630) 324-8585

Lead the washer harness through the central tunnel and under the dashboard.



49

FOR ALL TECHNICAL QUESTIONS, PLEASE CALL
DFK AMERICA INC.
(630) 324-8585

Install the washer tank onto the washer tank holder and connect the washer motor to the washer harness.



DETAILED VIEW



Carefully cut of the dashboard switch blank.
Lead the wiper/washer switch harness branch through the dashboard.



Connect the wiper/washer switch with the wiper/washer switch harness branch and press the switch into the dashboard.

FOR ALL TECHNICAL QUESTIONS, PLEASE CALL
DFK AMERICA INC.
(630) 324-8585

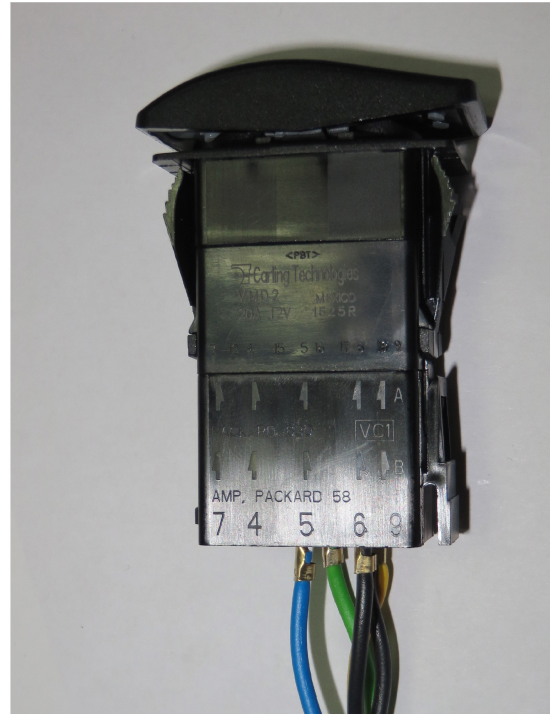

Drill the hole $\varnothing 16$ mm into the upper part of the dashboard.



Install the grommet into the hole.

FOR ALL TECHNICAL QUESTIONS, PLEASE CALL
DFK AMERICA INC.
(630) 324-8585



Lead the wiper motor harness branch with the washer tube around the UTV roller cage to the wiper motor.

53

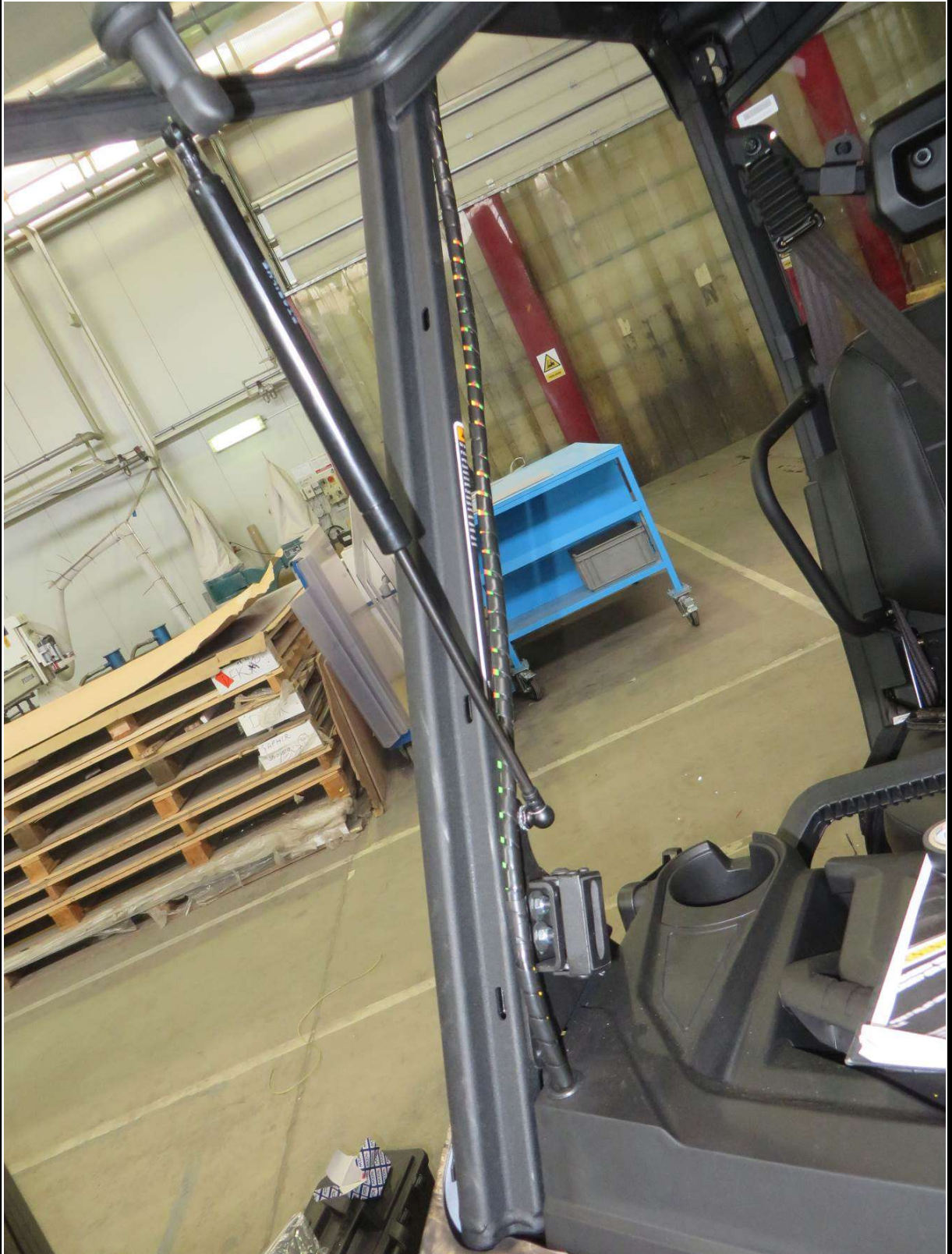

Install the harness cover ledge into the position and fix by included fixing assemblies. Lead the washer tube through the front glass and connect the tube to the washer jet.

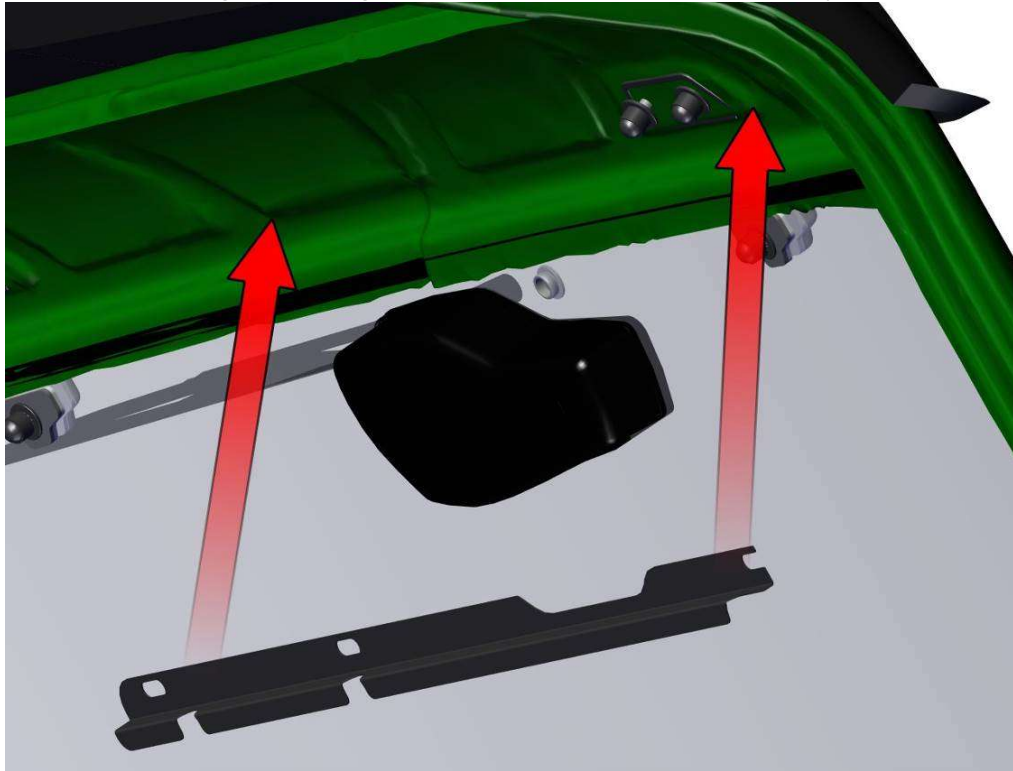

Connect the wiper harness branch to the wiper motor. DETAILED VIEW

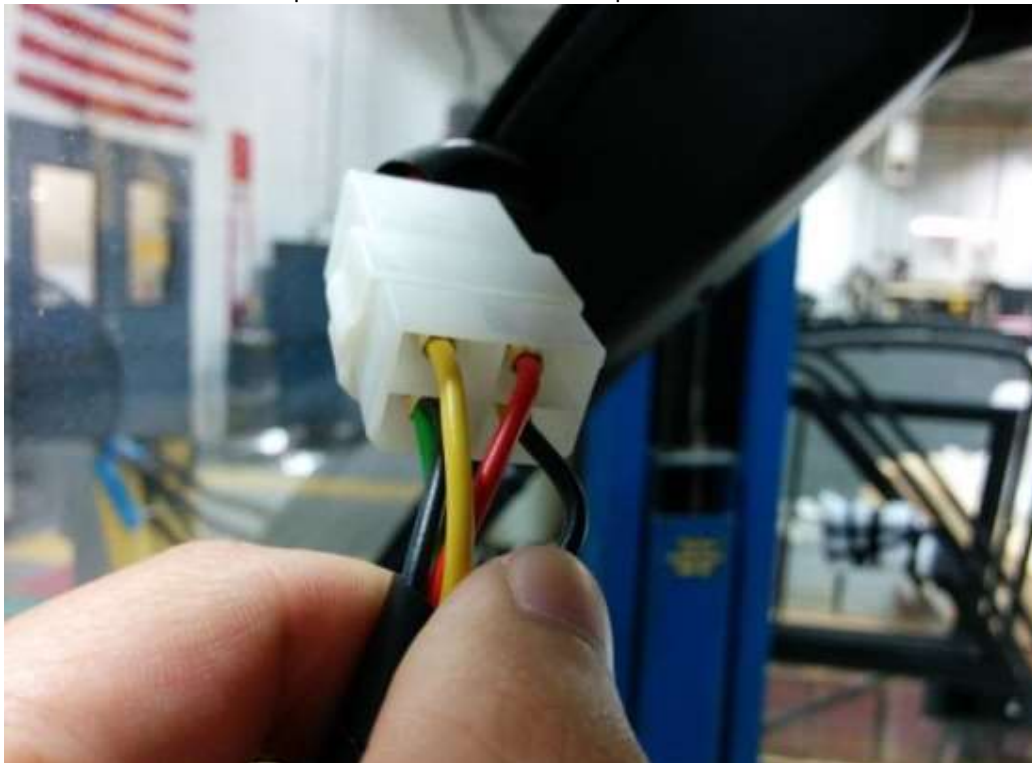

FOR ALL TECHNICAL QUESTIONS, PLEASE CALL
DFK AMERICA INC.
(630) 324-8585

Connect the wiper washer harness to the UTV original electroinstalation.



56

FILL THE WASHER TANK WITH THE WASHER LIQUID BEFORE FIRST USE.

ELECTROINSTALLATION
HEATER

IMPORTANT

IT IS ABSOLUTELY NECESSARY TO TAKE OUT THE RUBBER PLUGS FROM THE HEATER TUBES!!!

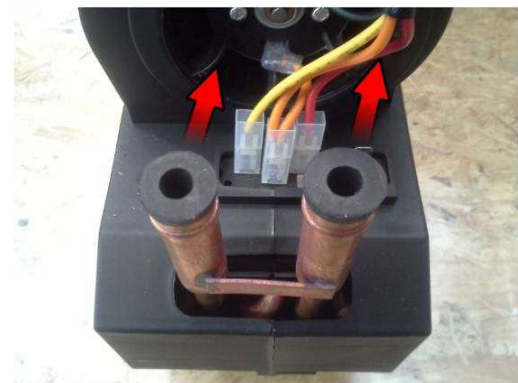
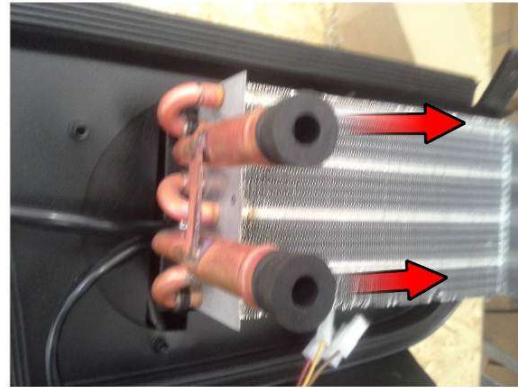

Uninstall front floor cover from the UTV. Cut the hole 12cmx12cm to the bottom part. DETAILED VIEW
Install the cover back.



SEE NEXT PAGES

58

Before drilling holes, check the space under the dashboard, and if necessary take the harness out of the way to prevent damage.

Cut two holes $\varnothing 55\text{mm}$ into the dashboard for the air vents



... lead the hot air hoses through DETAILED VIEWS

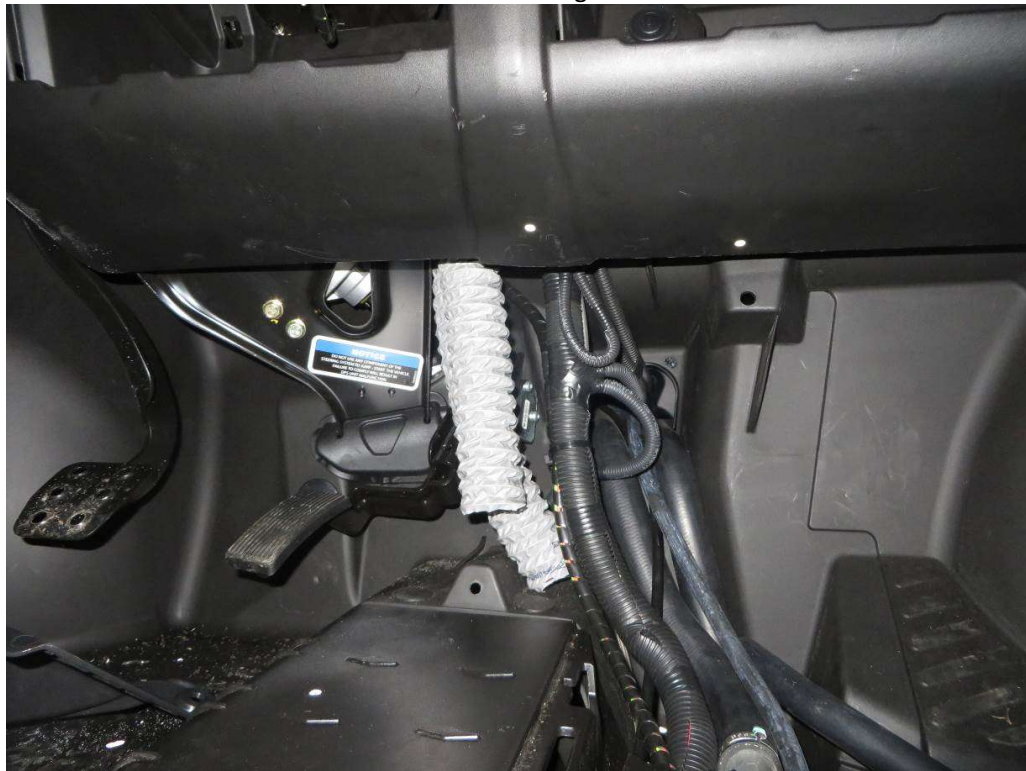

FOR ALL TECHNICAL QUESTIONS, PLEASE CALL
DFK AMERICA INC.
(630) 324-8585

Lead the hot water tube with the el.valve to the front radiator(red arrow). DETAILED VIEW



Cut the hot water hose and install the hot water pump, fix the hot water pump by tightening straps and tighten hard.

Connect the hot water pump to the pump harness and lead the harness back to the heater.



Secure the original cooling system hot water hose by clamps (not included), cut the hose and install included "Y" coupling into the hose. Connect the heater hose to the coupling and fix all ends by included tightening straps.



Cut the hose with the air vent to the correct length.



FOR ALL TECHNICAL QUESTIONS, PLEASE CALL
DFK AMERICA INC.
(630) 324-8585



CAN-AM
DEFENDER MAX

HardCabs →

It is absolutely necessary to bleed the air out of the UTV's engine cooling system. Incomplete bleeding of cooling system can result in engine damage. If you don't have sufficient experience with this process, we strongly recommend professional service technician assistance. We are not responsible for damages when cooling system bled incompletely. Please note that additional heater system will absorb more than 2 liters of coolant fluid.

- 1. Important: After the heater system installed check the system for leaks. Turn on the electric vent switch and confirm that the engine is cold. Start the engine, open bleeding valve and wait until engine warms up. Important: Always check engine temperature – if it overheats turn of engine.***
- 2. To achieve engine operating temperature depress the accelerator to increase The engine RPM. This will increase the pressure and flow of the water pump forcing more coolant through the heater. After operating temperature ceache turn of engine and open it. Trapped air should come out from heater system throughout bleeding valve. Repeat this procedure until heater/cooling system is completely bled out.***

The DFK Cab heater, like the heater in a car, generates heat from the vehicle's engine.

In nearly all cases, the heater should generate enough heat from your UTV, side by side, or tractor engine that you may need to turn the heater off periodically otherwise the air in the cabin may be too hot.

It is important to check the coolant level regularly at least 4-5 times during the first several days of operation and fill as necessary until the coolant level has stabilized. The heater will draw and retain coolant, sometimes at the expense of coolant to the engine. This can cause engine overheating if not managed properly.



Secure the original cooling system cold water hose by clamps (not included), cut the hose and install included "Y" coupling into the hose. Connect the heater hose to the coupling and fix all ends by included tightening straps.

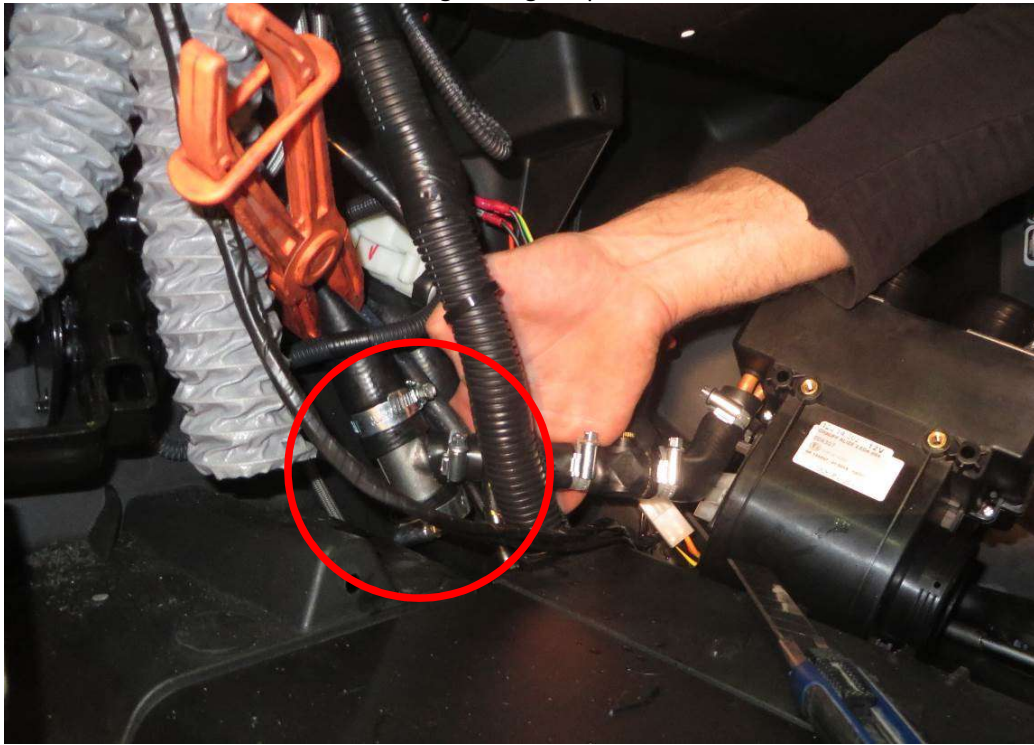

Connect the el, valve to the el.valve harness branch. DETAILED VIEW

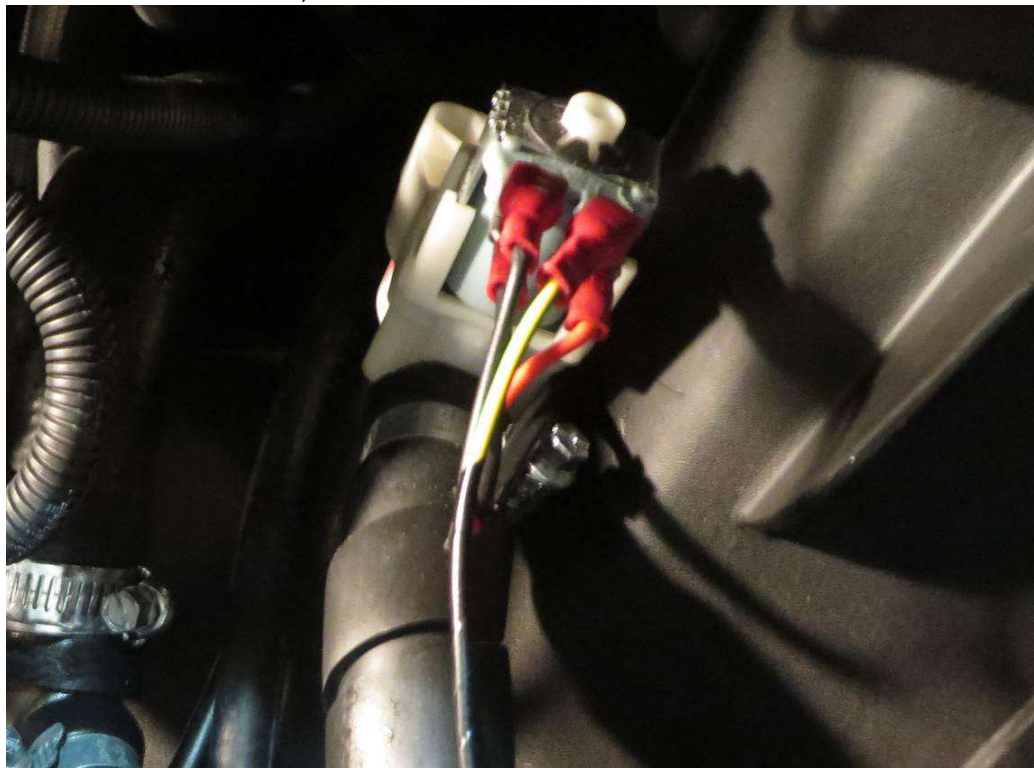

FOR ALL TECHNICAL QUESTIONS, PLEASE CALL
DFK AMERICA INC.
(630) 324-8585

Connect the heater to the heater harness branch. DETAILED VIEW

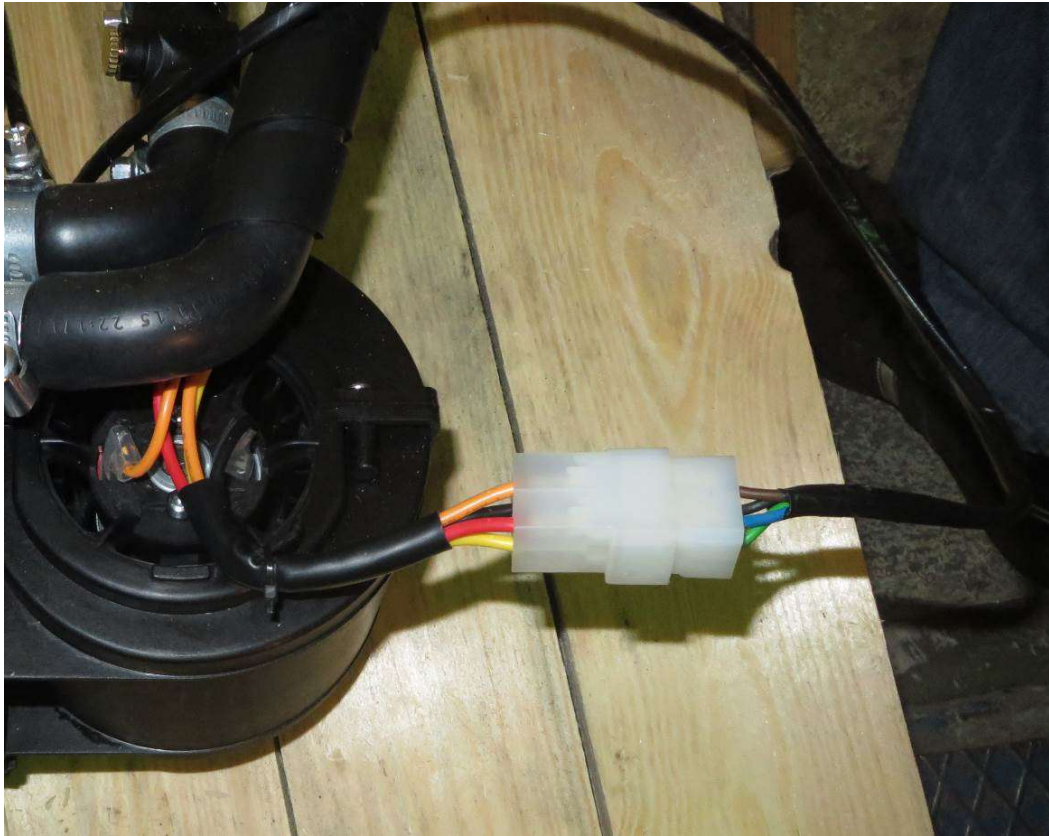

Install the heater holder onto the heater and fix by included screws and washers.

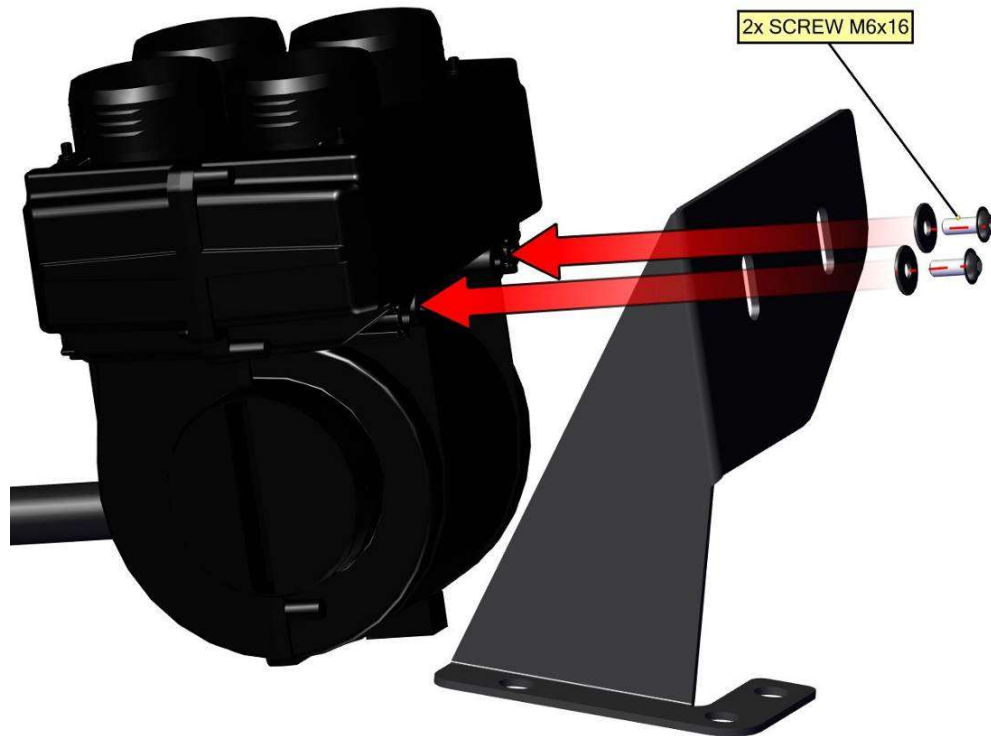

FOR ALL TECHNICAL QUESTIONS, PLEASE CALL
DFK AMERICA INC.
(630) 324-8585

Place the heater assembly onto the UTV floor and fix by included fixing assemblies.
It is necessary to drill holes for the rubber nuts in accordance with the heater holder holes.



66

Connect the prepared hot air hoses PVC to the heater vents and fix by included Al. tape. DETAILED VIEW



Prepare two shorter pieces of the hot air hose PVC to the rest of heater vents and fix by al. tape.
DETAILED VIEW



FOR ALL TECHNICAL QUESTIONS, PLEASE CALL
DFK AMERICA INC.
(630) 324-8585

Connect the valve harness and the pump to the pre-installed valve switch.

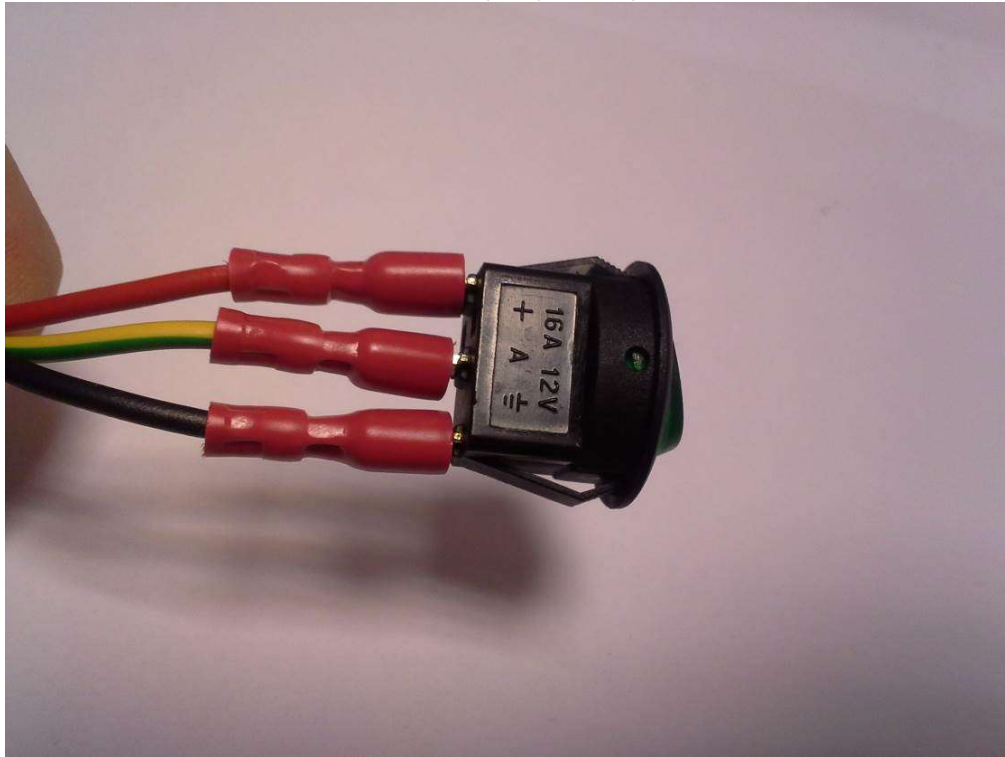

Connect the heater harness to the heater switch base.

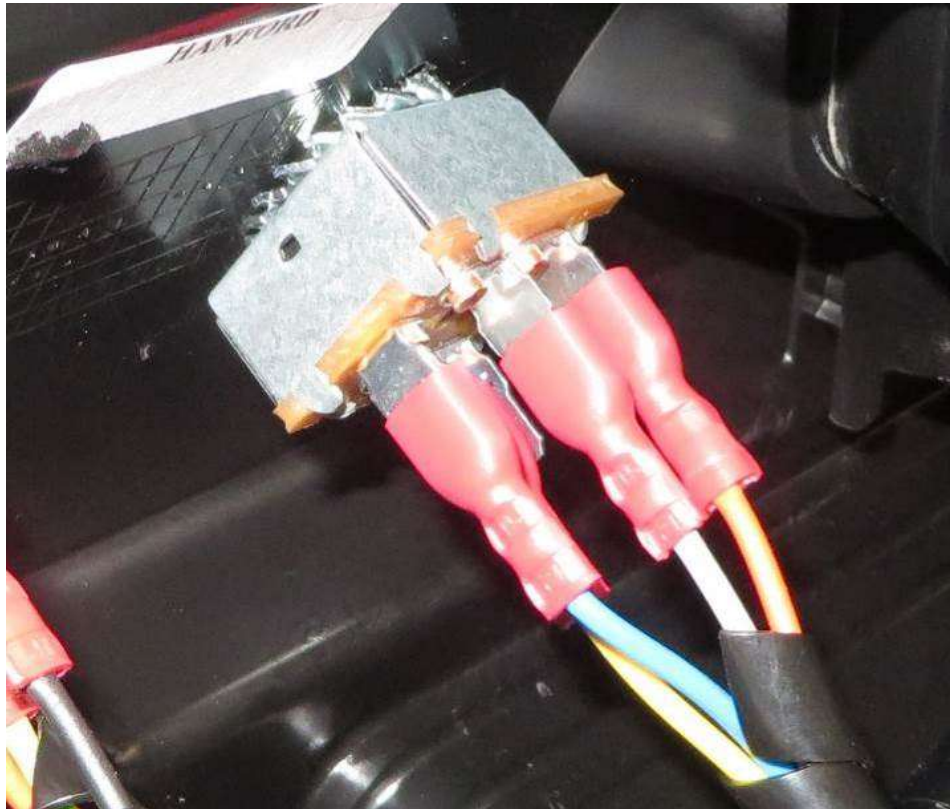

FOR ALL TECHNICAL QUESTIONS, PLEASE CALL
DFK AMERICA INC.
(630) 324-8585

Cut the hot air hoses PVC to the correct length, connect the hoses to the air vent and fix by tightening straps. DETAILED VIEW



Repeat previous step with the dashboard air vents and press the vents into the dashboard.



FOR ALL TECHNICAL QUESTIONS, PLEASE CALL
DFK AMERICA INC.
(630) 324-8585

Lead the harness under the dashboard and connect the heater harness to the original electroinstalation.



70

SEE NEXT PAGES

Place the heater cover with all tubes and harnesses connected into the best position and fix it by included rubber rivets. If necessary drill holes $\varnothing 8\text{mm}$ for the rubber rivets.



71