



*INSTALLATION INSTRUCTIONS*

**YAMAHA**

**VIKING**

**YANMAR**

**BULL**

## **SAFETY INSTRUCTIONS**

***Warning: Failure to heed all safety and operating instructions and warnings regarding use of this product can result in serious bodily injury.***

### ***READ PROPERLY COMPLETE ASSEMBLY INSTRUCTIONS BEFORE STARTING OF ASSEMBLY***

***Install all parts indicated in assembly instructions. Failure to fully assemble product before use could result in personal injury.***

***Assembly of product requires use of hand or power tools. If you are not experienced in using these types of tools, have product dealer do the install for you.***

***Some parts contain sharp edges, wear protective gloves if necessary. Always keep your assembly area clean, uncluttered and well lit.***

***Keep visitors and children a safe distance away from the assembly area. Visitors should wear the same safety equipment described under.***

***Never operate your UTV with the cab doors open. Failure to properly latch the doors before moving the vehicle could result in serious injury.***

***Dress for safety. DO NOT wear loose clothing, gloves, neckties or jewelry if using power tools to assemble this product. Insert all nut covers after you finish installation.***

***Never drive your UTV with the cab front window in open position.***

***Failure of improperly latched/locked front window before driving the vehicle could result in serious injury.***

## **MAINTANCE AND CLEANING**

*To clean polycarbonate surface use soapy water solution or other subtle means.*

*Dirt and dust wash by gently water stream and swipe only with wet or damp means in the direction from top to bottom.*

*The recommended frequency of cleaning of polycarbonate part is about 1 time per month or according to the actual degree of pollution.*

*Do not use detergents that could scratch the surface plates. (abrasives, harsh fabrics, etc.)*

*Do not use solvents or alkaline detergents or cleaners with ammonia (ammonium hydroxide).*

*Do not remove the impurities from the surface of the razor blades or other sharp items.*

*Do not clean cabine, when the polycarbonate plates are heated by the sun.*

*Do not use the squeegee, it could be scratched surface plates.*

*Do not clean the water current strength greater than 50 bar (WAP)*

*The manufacturer is not responsible for scratching the surface in case of failure to comply with the above instructions.*

*All bolted connections of cab must be by user at regular intervals checked and tightened.*

### HEATER

Loosen the middle seats four fixing screws (red circles) and remove the seats from vehicle.



4

Remove screws from each side of center floor console. Lift back of console, disengage tab from front, then remove console from vehicle.

Retain screws.



5

Open door to upper storage compartment then remove compartment/door assembly from dash.



Place the heater holder onto the dashboard and mark the fixing points position. Drill two holes  $\varnothing$  8 mm for plastic push pins.

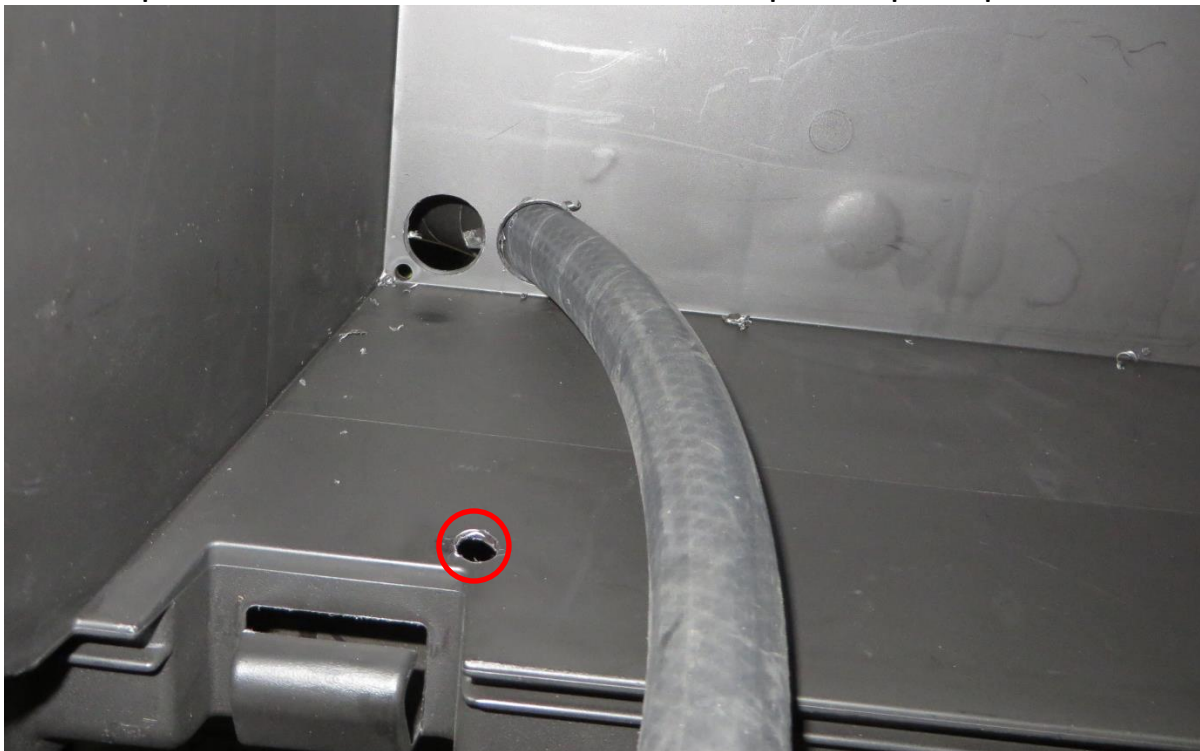

Drill three holes  $\varnothing$  30 mm into the bottom of the compartment for the heater water hoses and for harnesses.

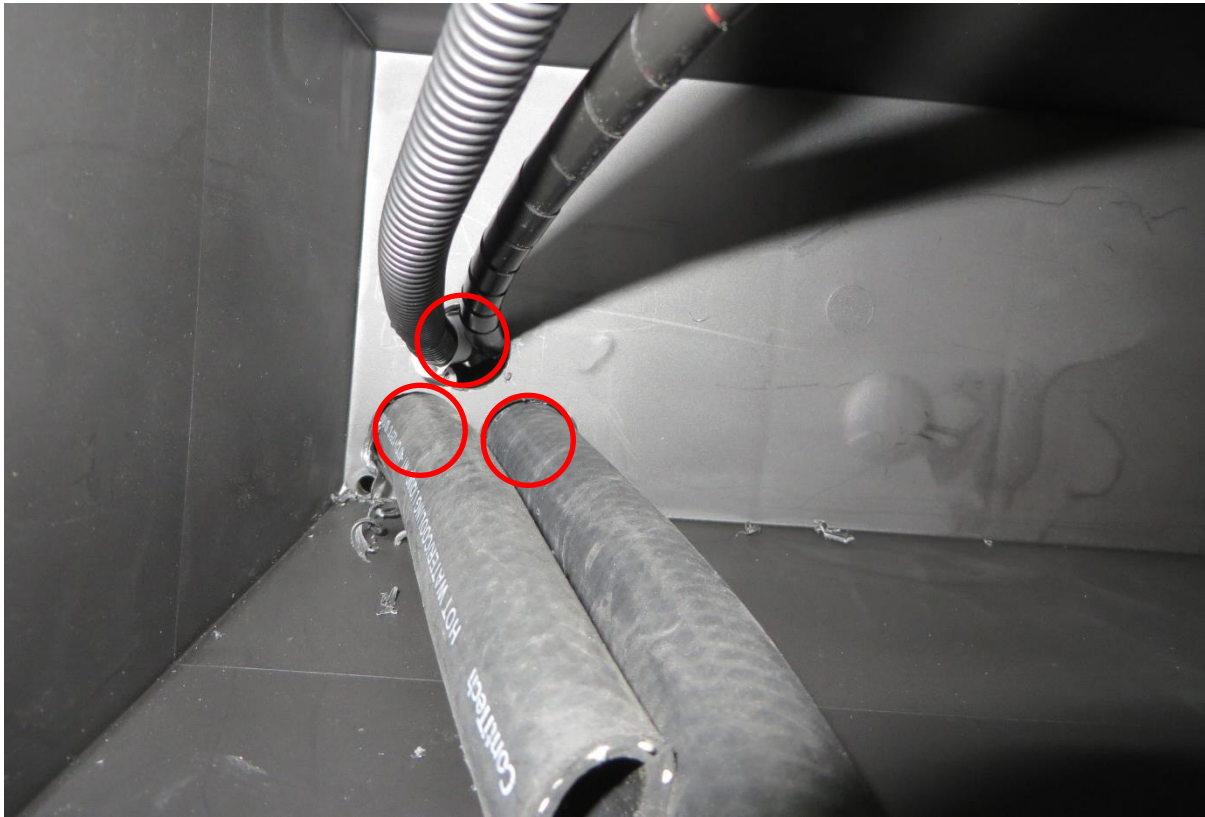

Route the heater water hoses and the heater and water pump harness through the prepared holes.



Attach the heater holder with four included plastic push pin rivets. Upper fixing points (red circles).



And two bottom fixing points on both sides of the heater holder.





Locate the original electroinstallation relays inside the under dashboard space.



Dismount the relays from the relay holder.

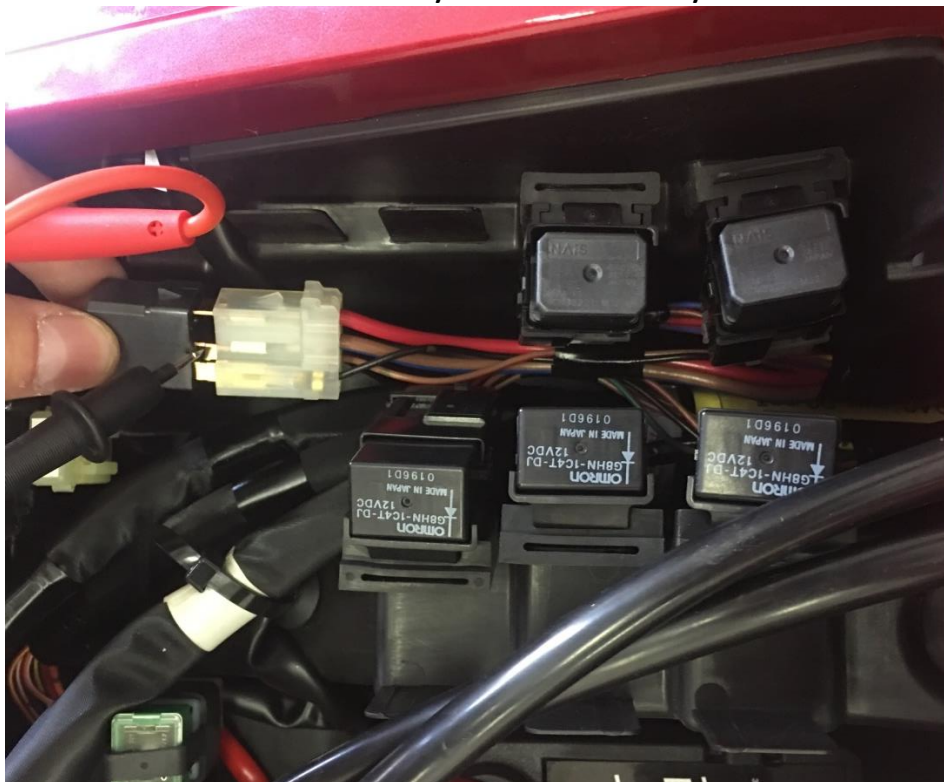

Locate the brown/blue wire on the relay connector. Uninstall the original black/white wire pin from the connector.



Install the included red wire pin into the connector.

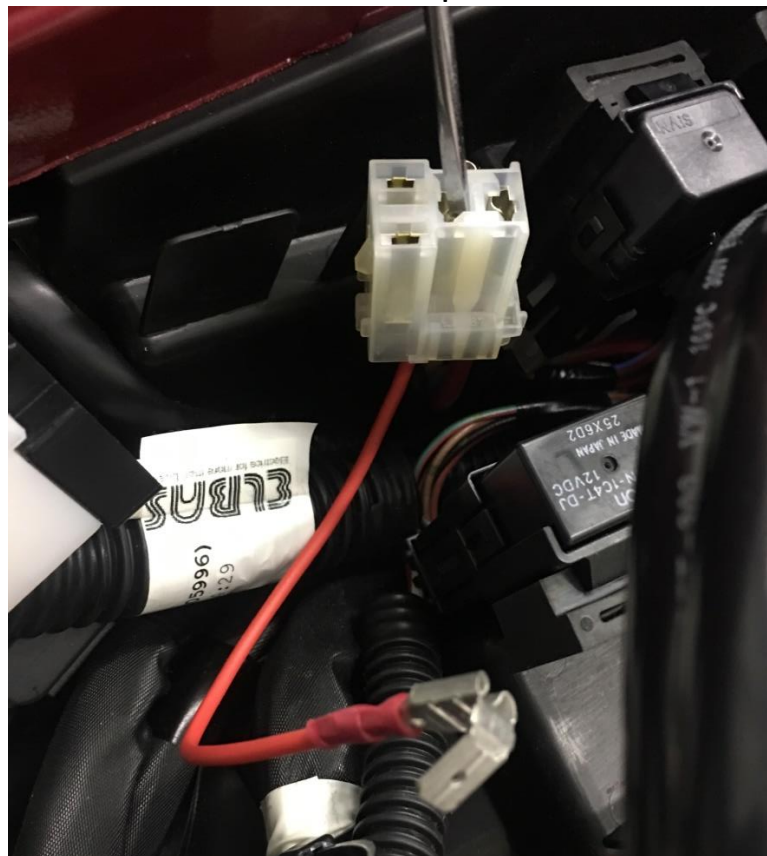

Connect the red wire male pin (original pin relay) from the relay harness to the red wire male multi-stack disconnector terminal. The second relay harness white wire remains unconnected.

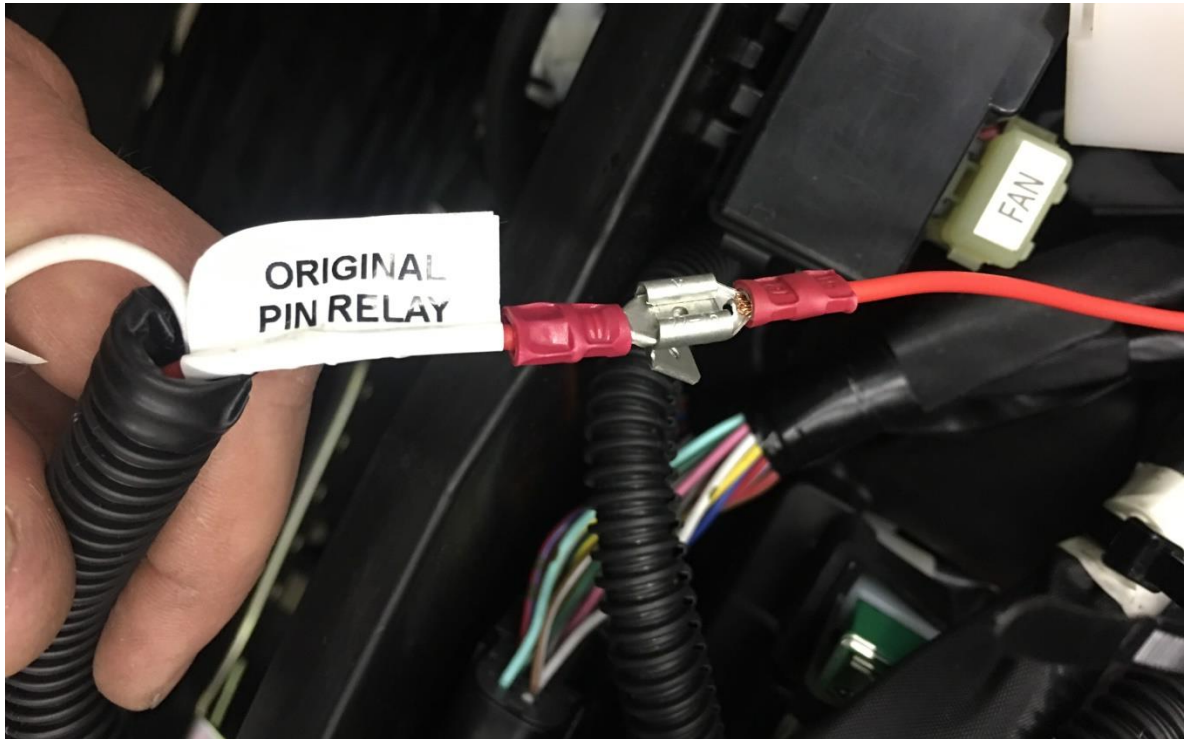

Connect the original brown/blues wire with



Route the relay harness through the original hole from the under hood space to the front right wheel space.



Connect the heater, wiper and washer harness with the relay harness



Prepare the output heater water hose for installation.



Route the hose through the prepared hole on the right to the storage compartment. Connect the hose to the bleeding valve and attach with included tightening strap.

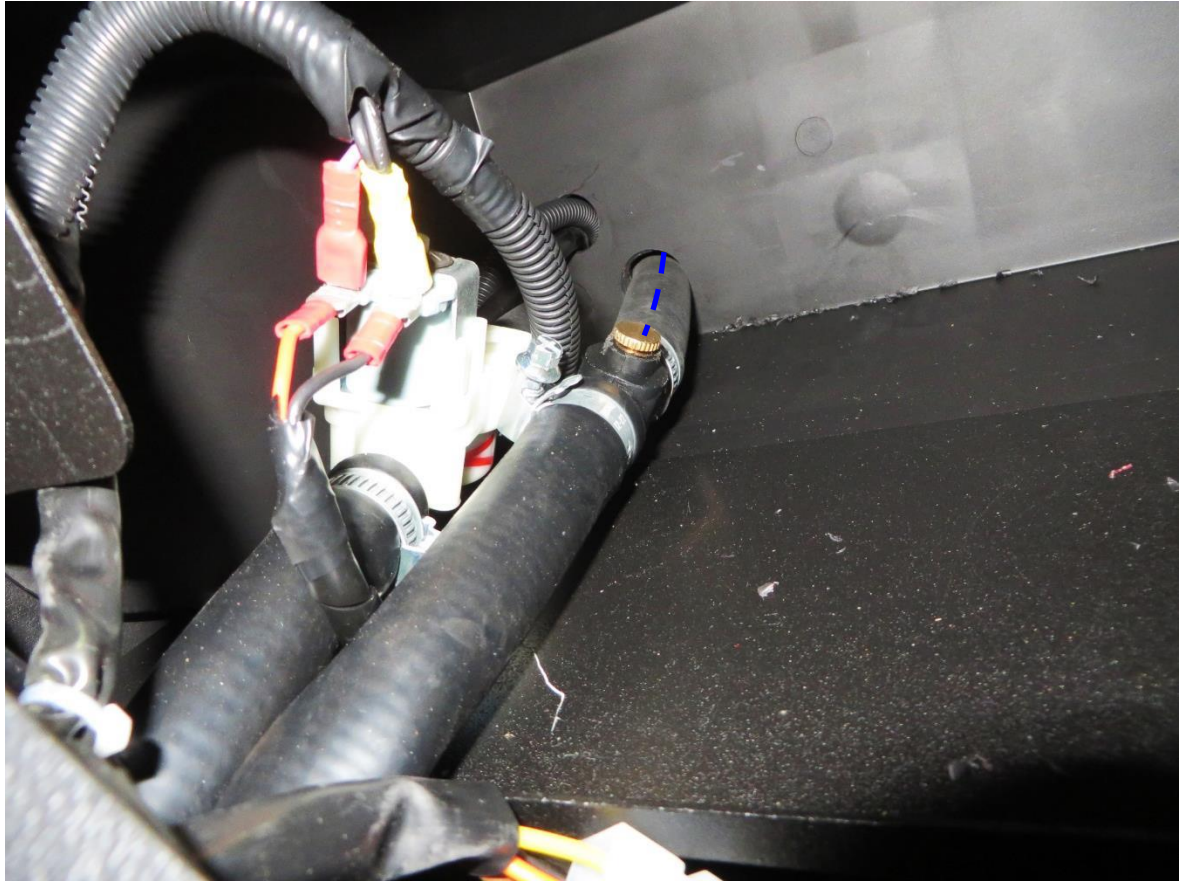

Route the output heater hose from the heater to the radiator.

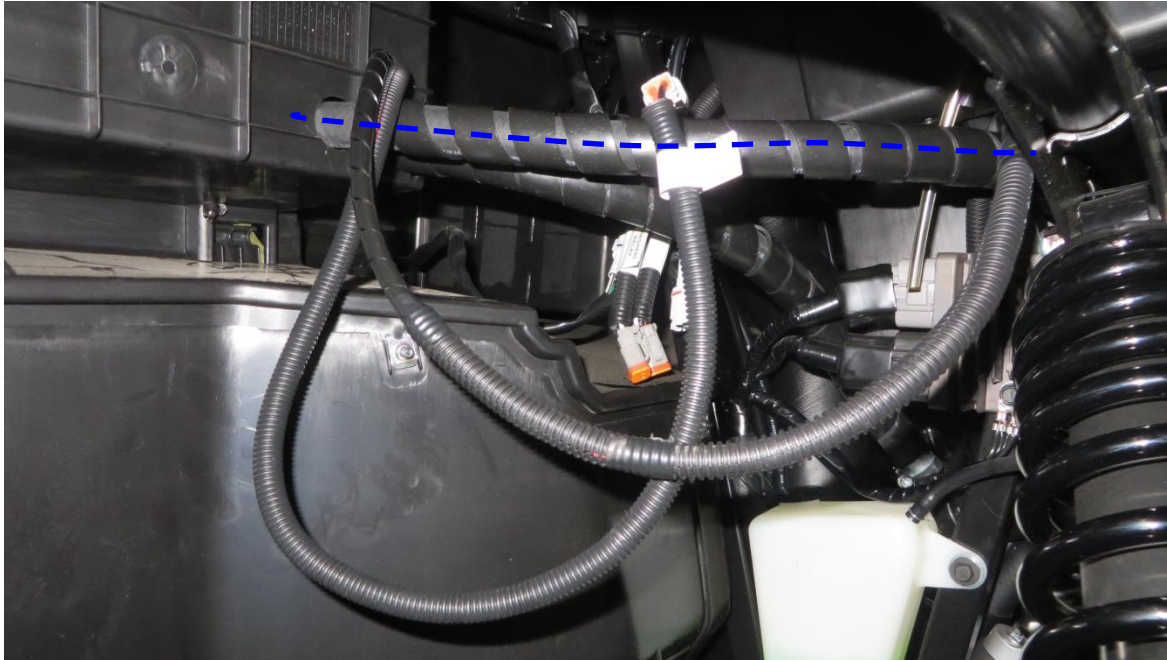

Secure the original cooling system hose with clamps. Cut the hose between clamps. Cut a 2 cm long piece of hose. Install the "Y" coupling onto the both end of the cutted hose. Attach the both end of hose with tightening straps

14



Prepare the input heater water hose with water pump for installation.

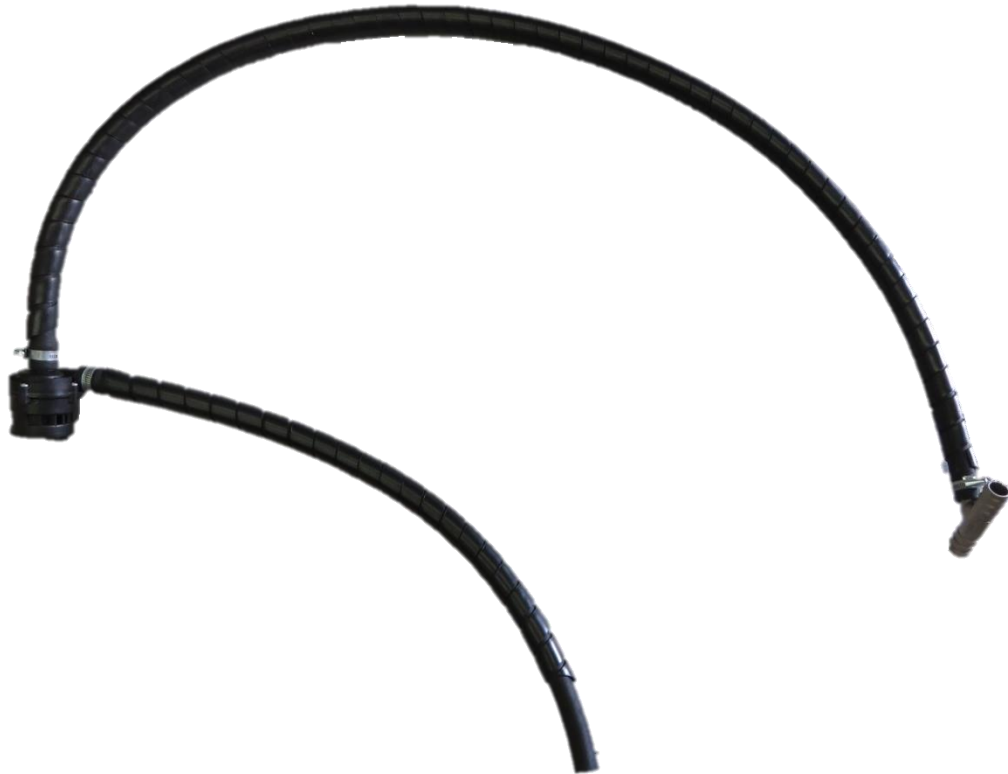

Route the hose through the prepared hole on the left to the storage compartment. Connect the hose to the electromagnetic valve and attach with included tightening strap.

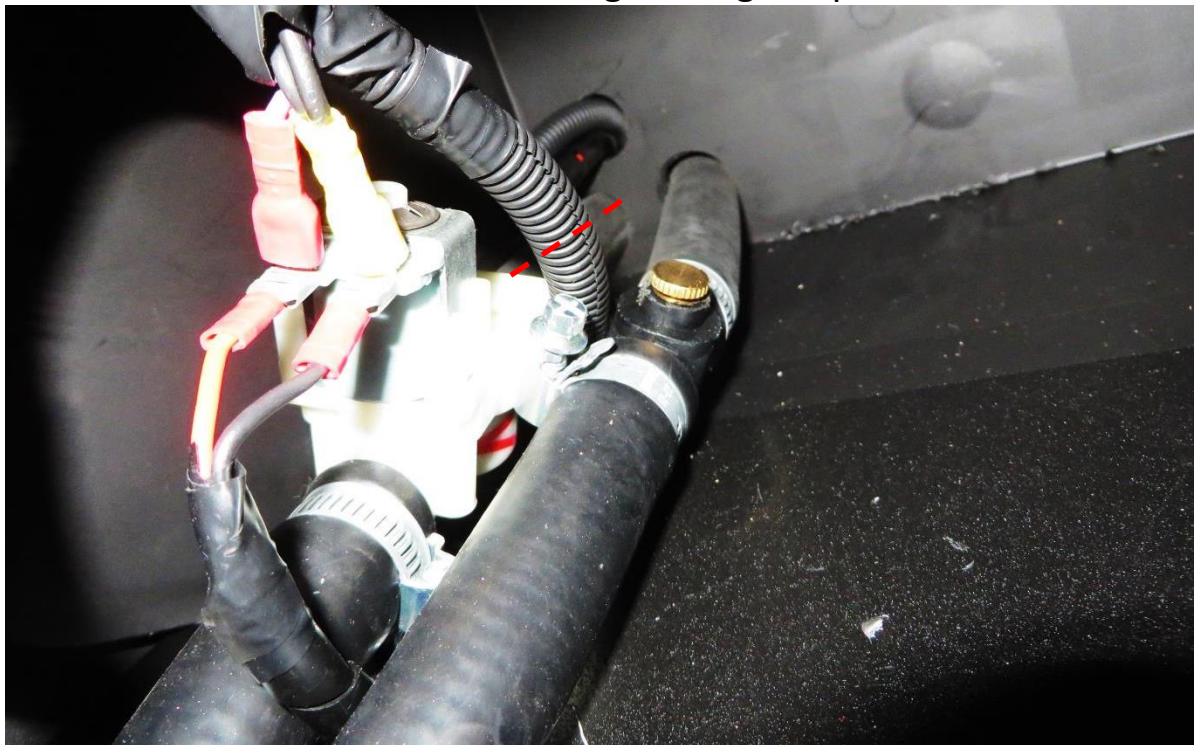

Locate the original cooling system hose for heater hot water hose connection.

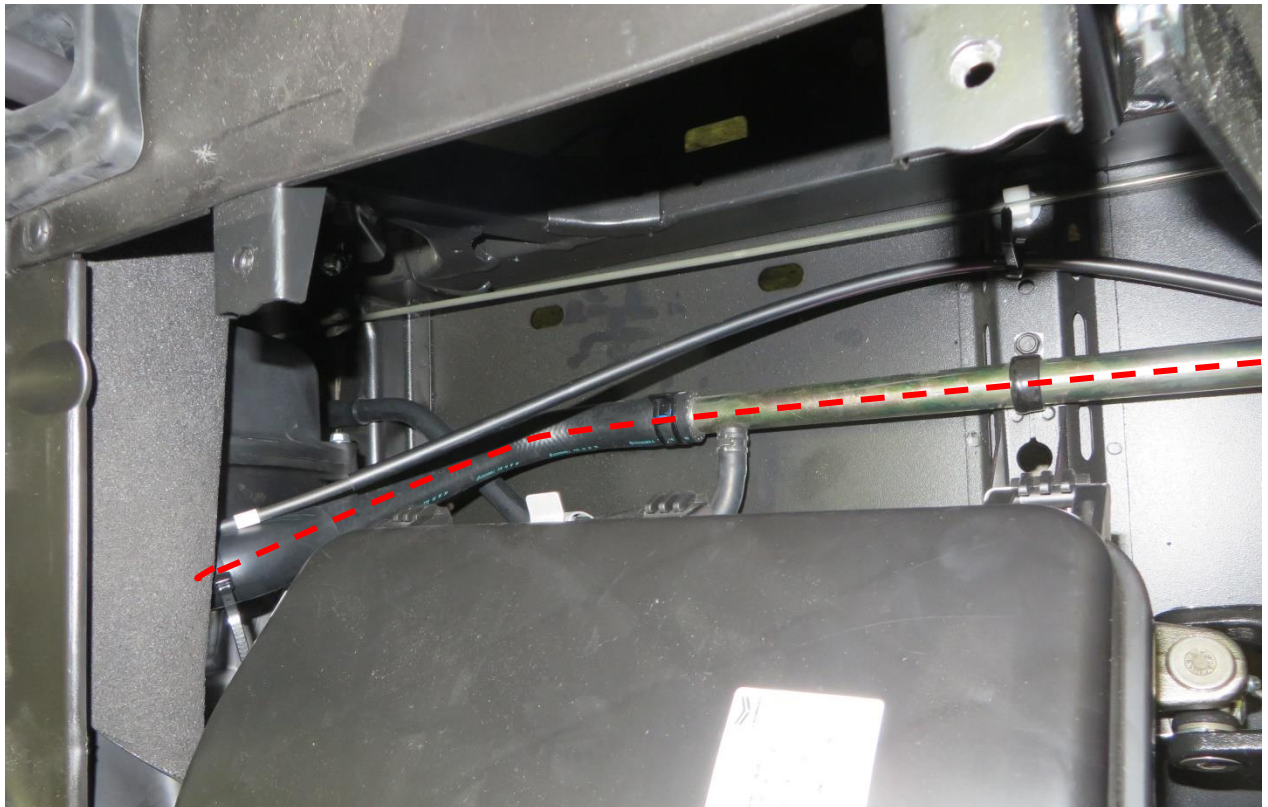



Connect water pump harness male multi-stack disconnecter terminals to the electromagnetic valve. Connect the electromagnetic valve harness to male multi-stack disconnecter terminals.

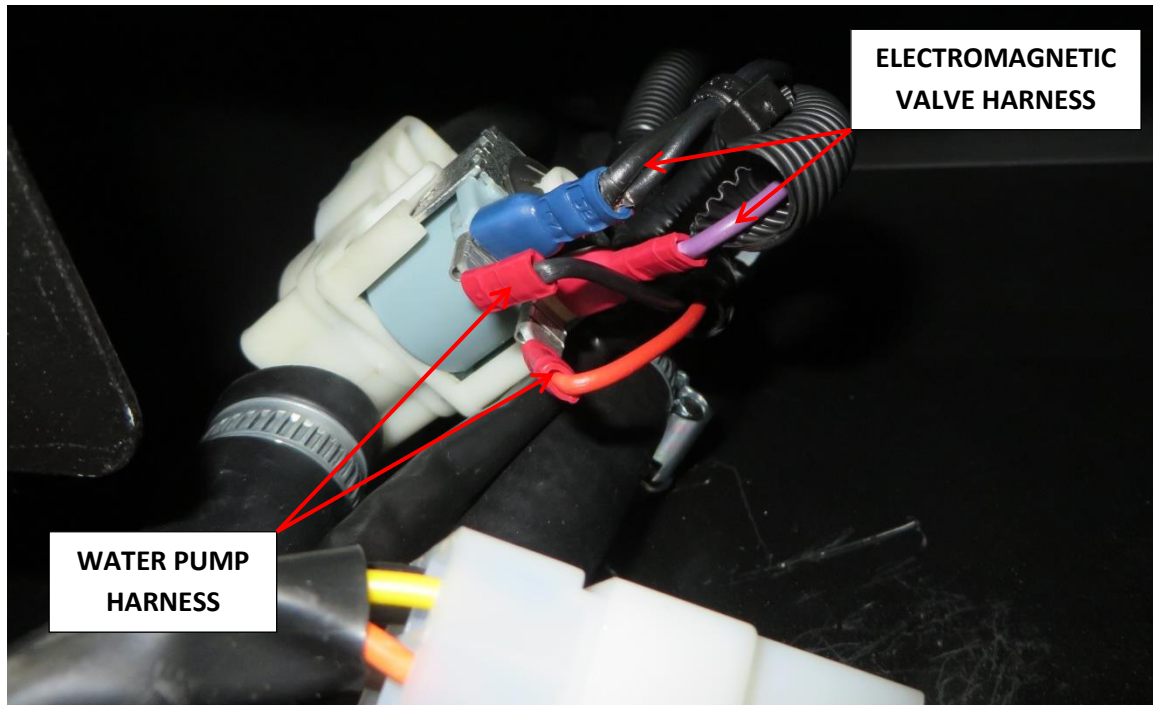

Route the input heater hose from the heater to the engine space.

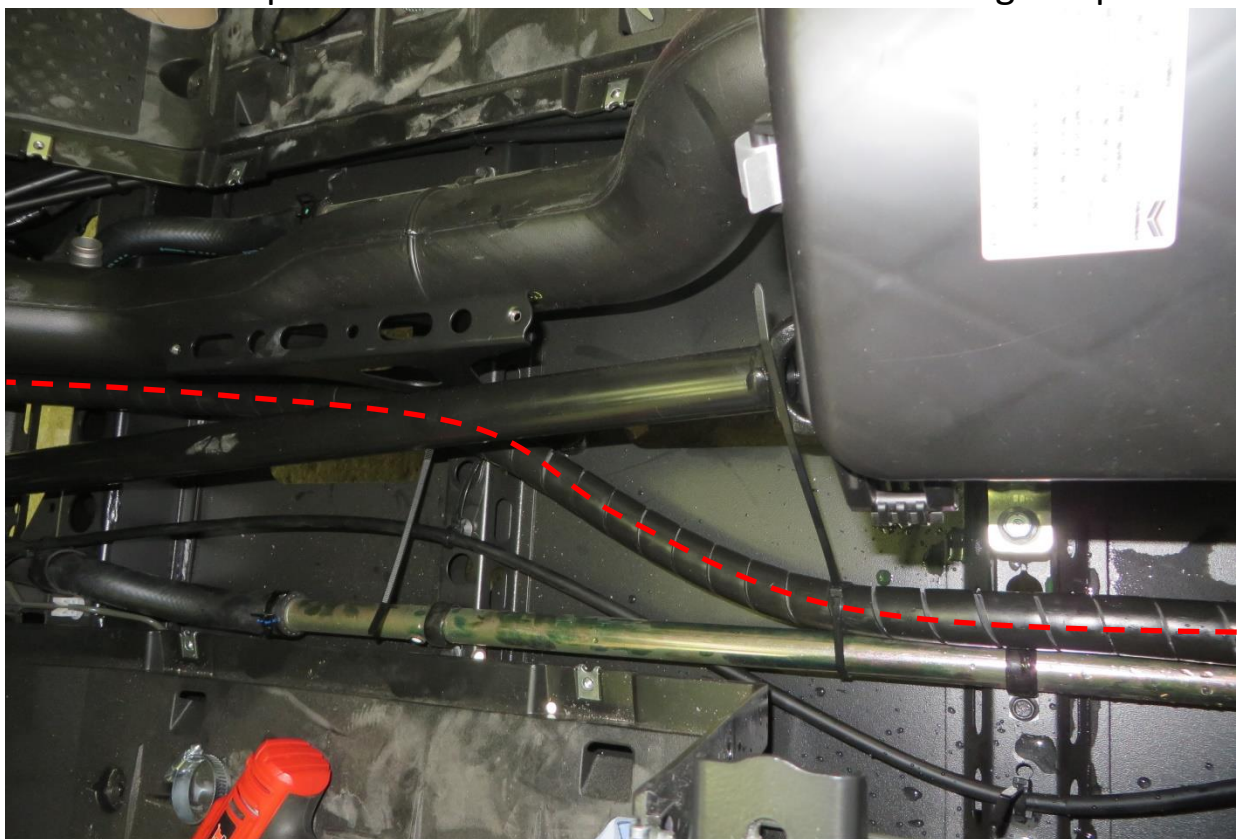

Locate the original cooling system hose for heater input.

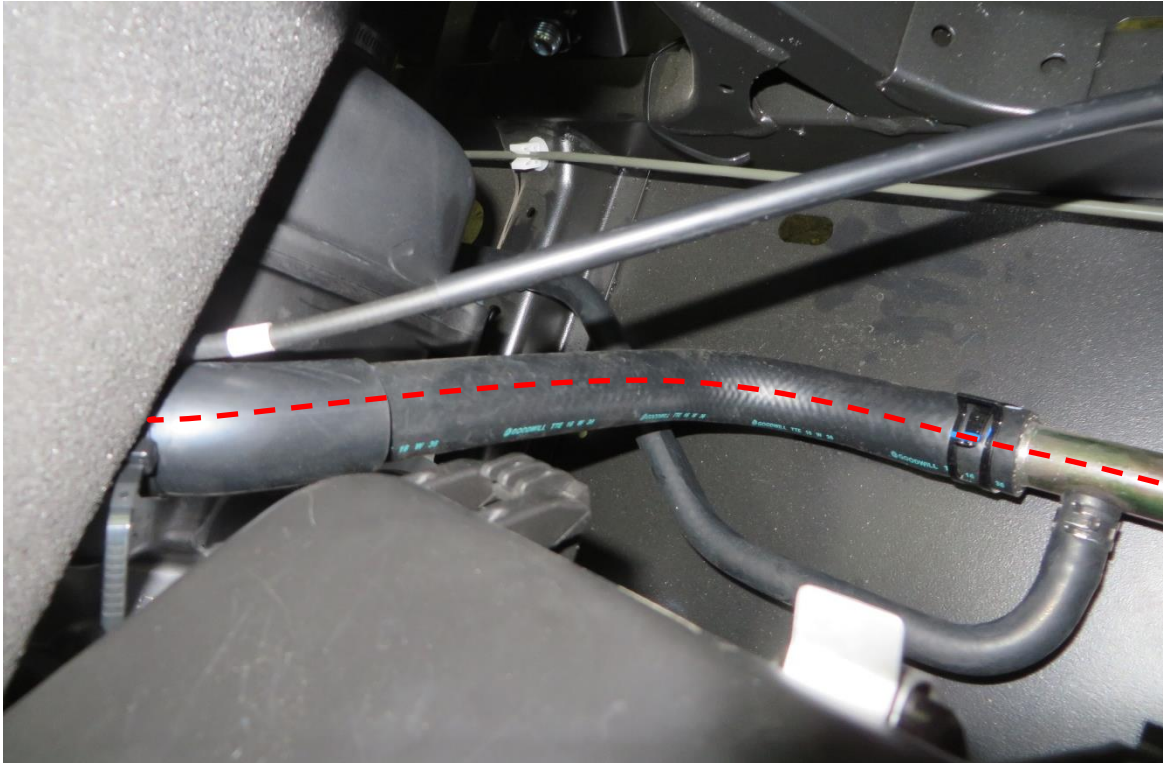

Secure the original cooling system hose with clamps. Cut the hose between clamps. Cut a 2 cm long piece of hose. Install the “Y” coupling onto the both end of the cutted hose. Attach the both end of hose with tightening straps

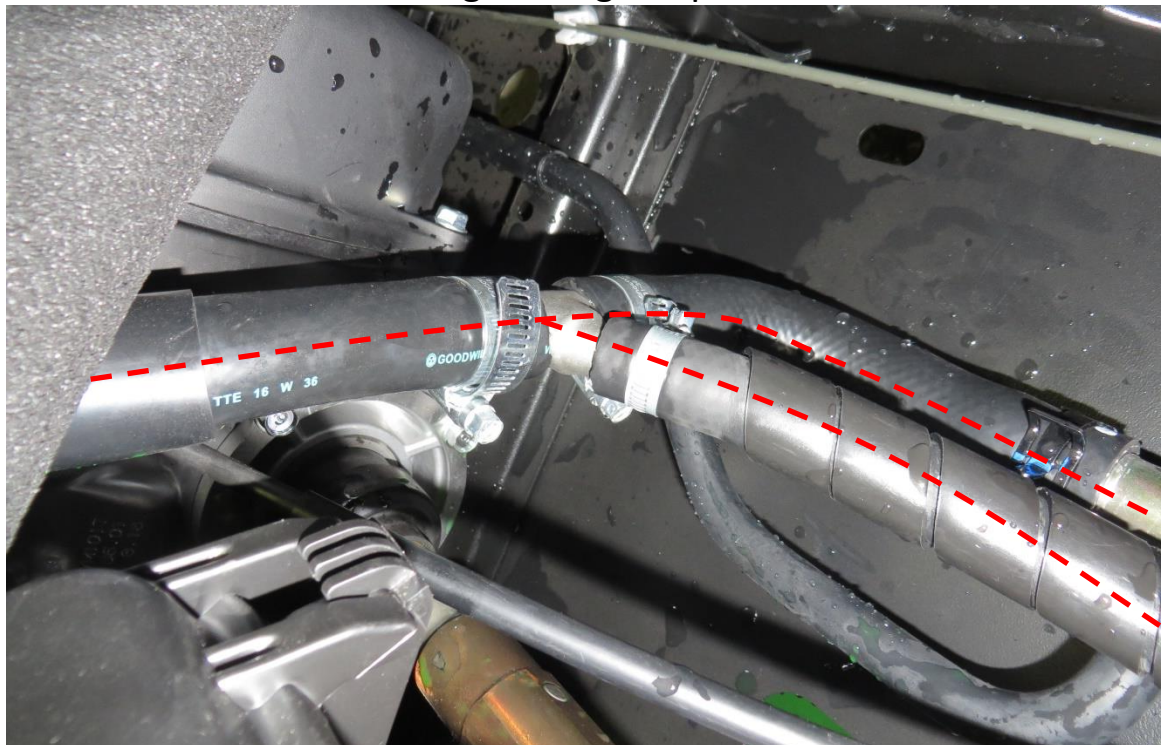

Mount the center floor console back to original position with original screws.



19

Attach the heater with included screws on both sides.



20

Connect the water pump harness connector with the water pump.

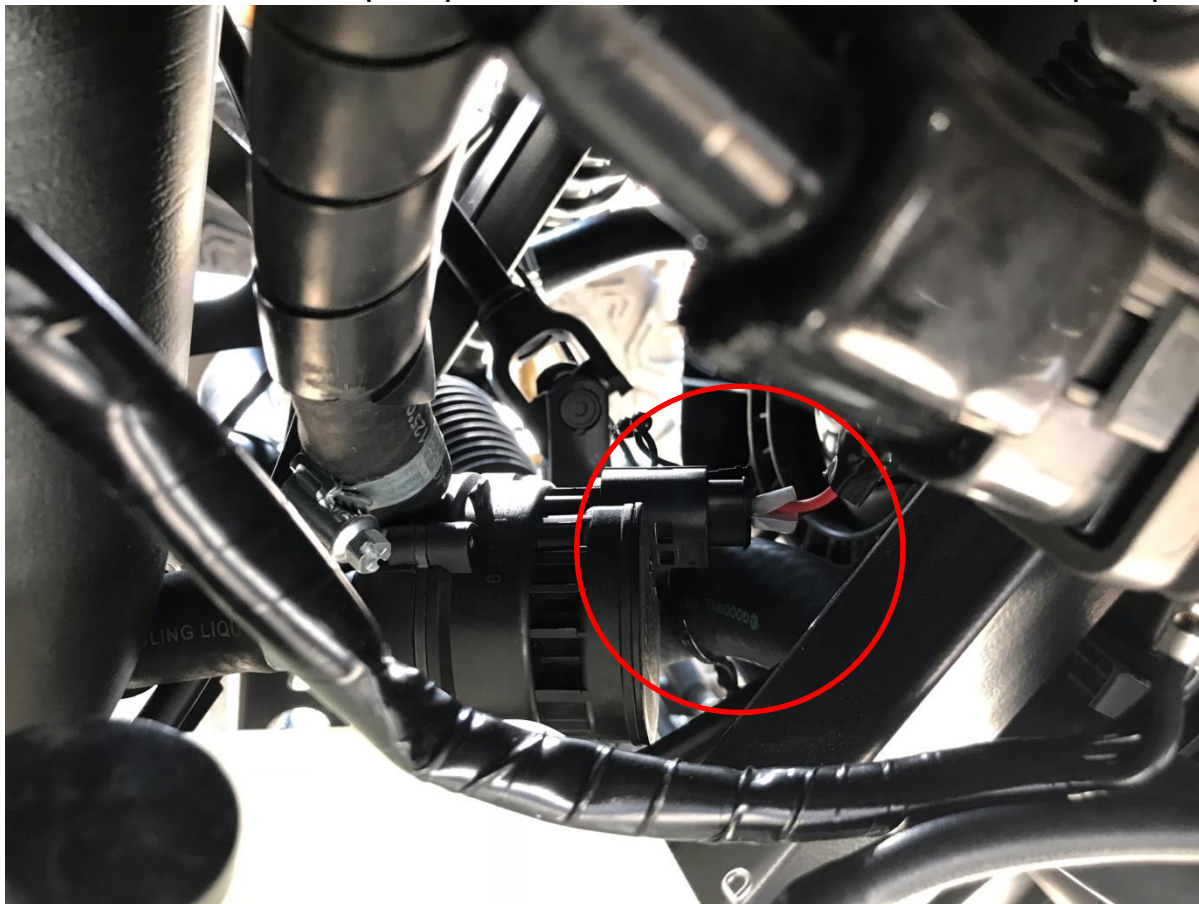

21

**WASHER**

Connect the washer harness and the washer tube with the washer motor.

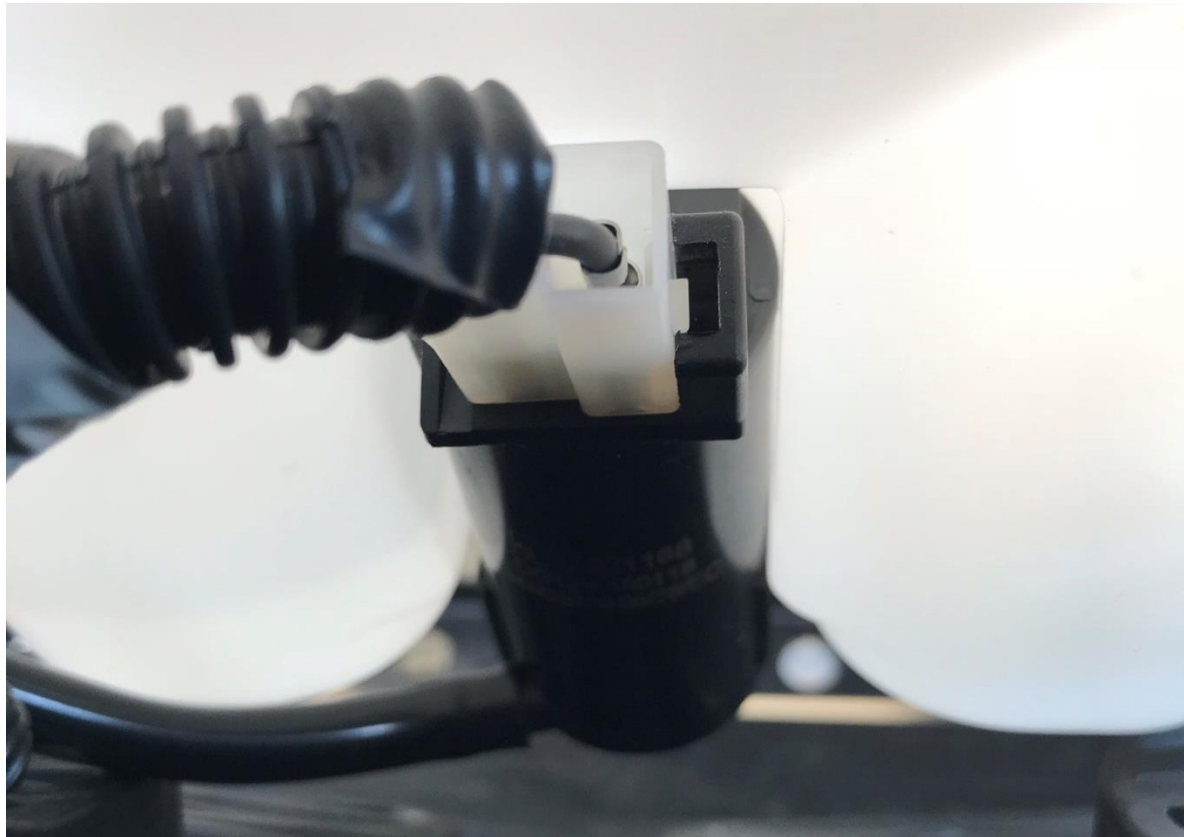

Attach the washer tank onto the radiator ledge with included fixing assembly.



22

Route the relay harness through the original hole from the under hood space to the right front roll cage tube.

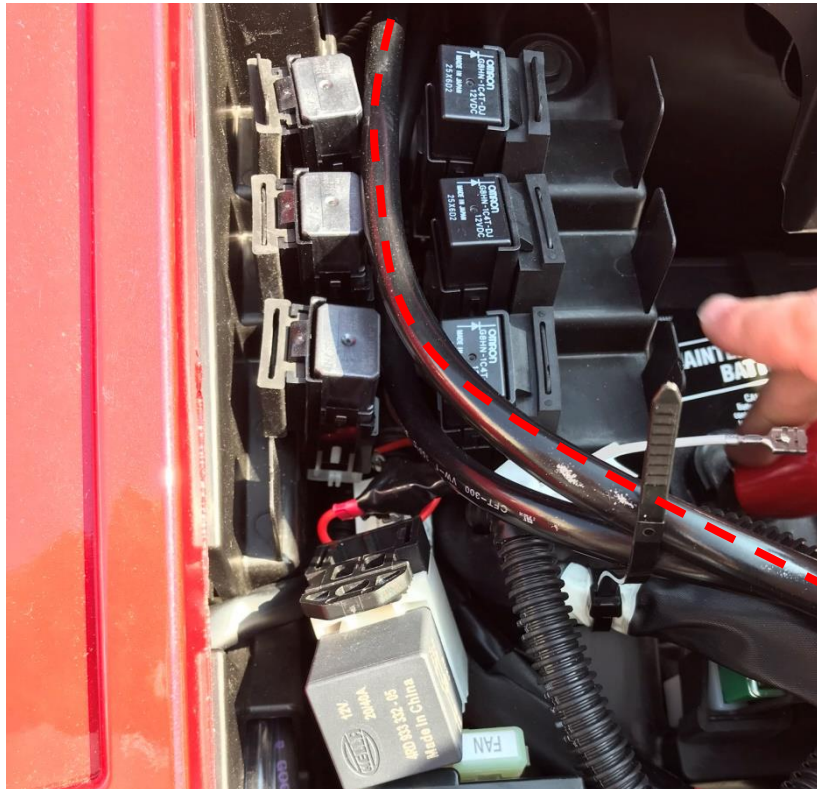

Route the washer harness hole from the under hood space to the right front roll cage tube.



Attach the wiper and washer harness onto UTV frame with included tightening ties.

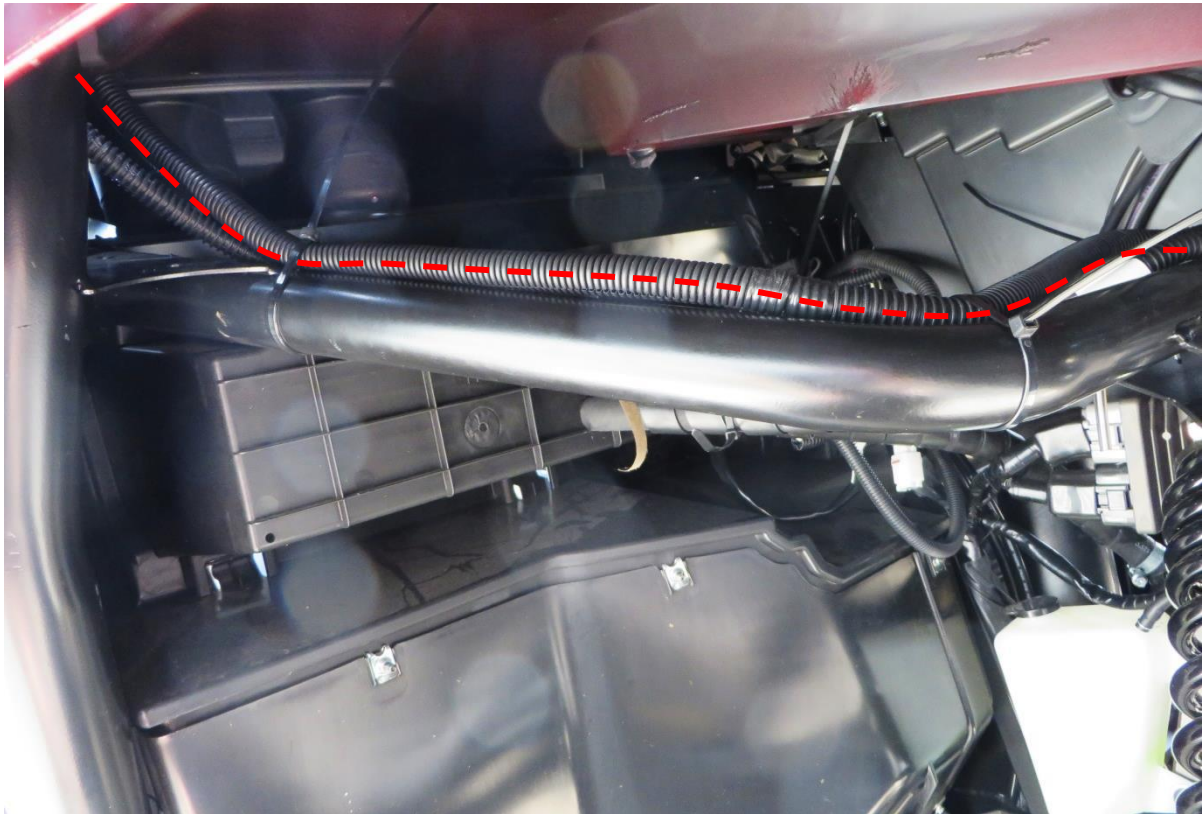

Push the washer harness through the space between UTV body and the right front roll cage tube.





WIPER

Drill hole  $\varnothing$  18 mm to the plastic UTV body next to the right front roll cage tube for the wiper harness.



Route the washer and wiper harness on the right front roll cage tube. Attach the harnesses with included tightening ties.



Route the wiper and washer harness to the wiper motor.

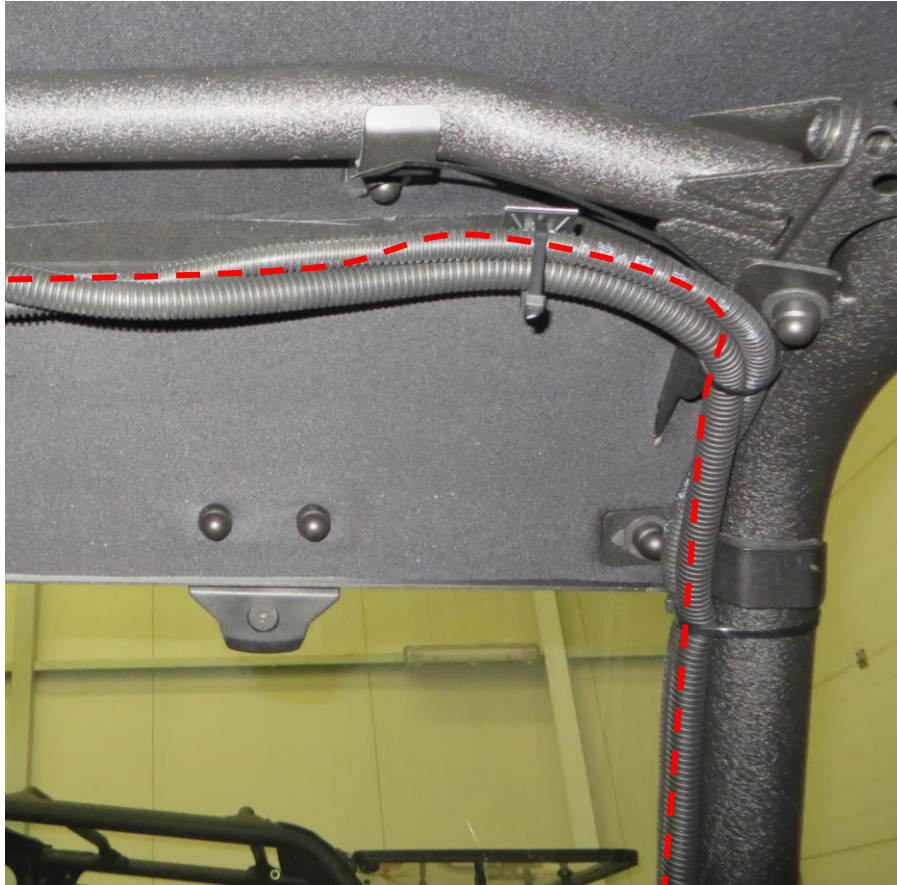

Connect the washer tube with washer tube 90 degree bulkhead joiner.



Connect the washer tube with the washer jet.

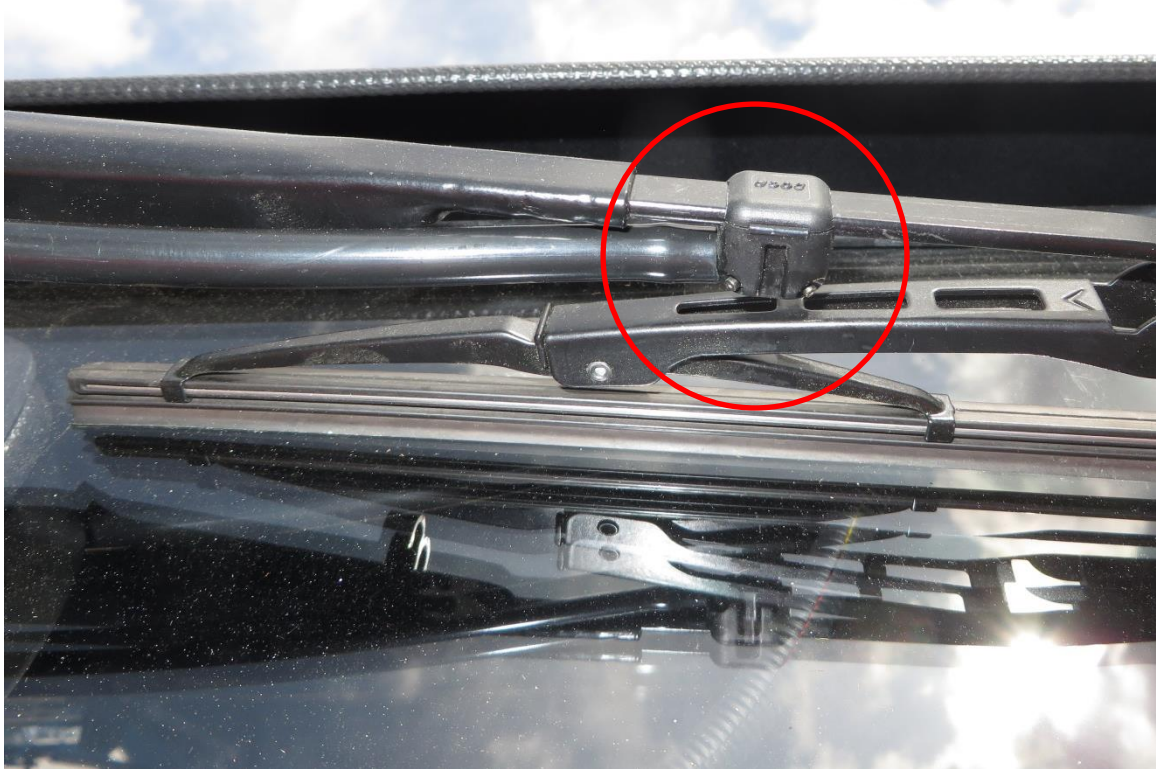

Connect the wiper and washer harness with the control panel harness and connect the washer tube together.

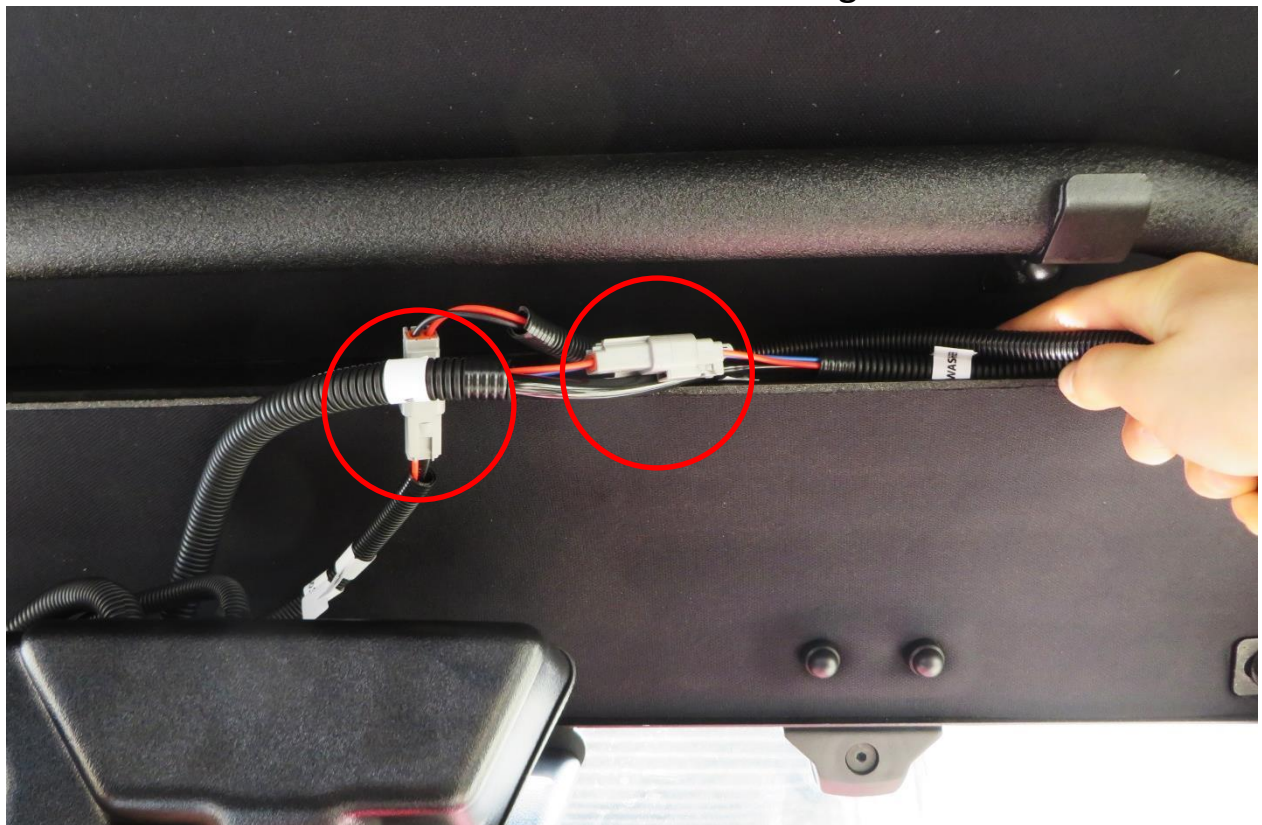

27

**PREPARATION FOR INSTALLATION:**

Uninstall all additional systems from the roller cages (work lights, rear mirrors, drink holders etc.) Uninstall the original roof and the original doors from the roller cage and save these carefully.



Original door detail view.

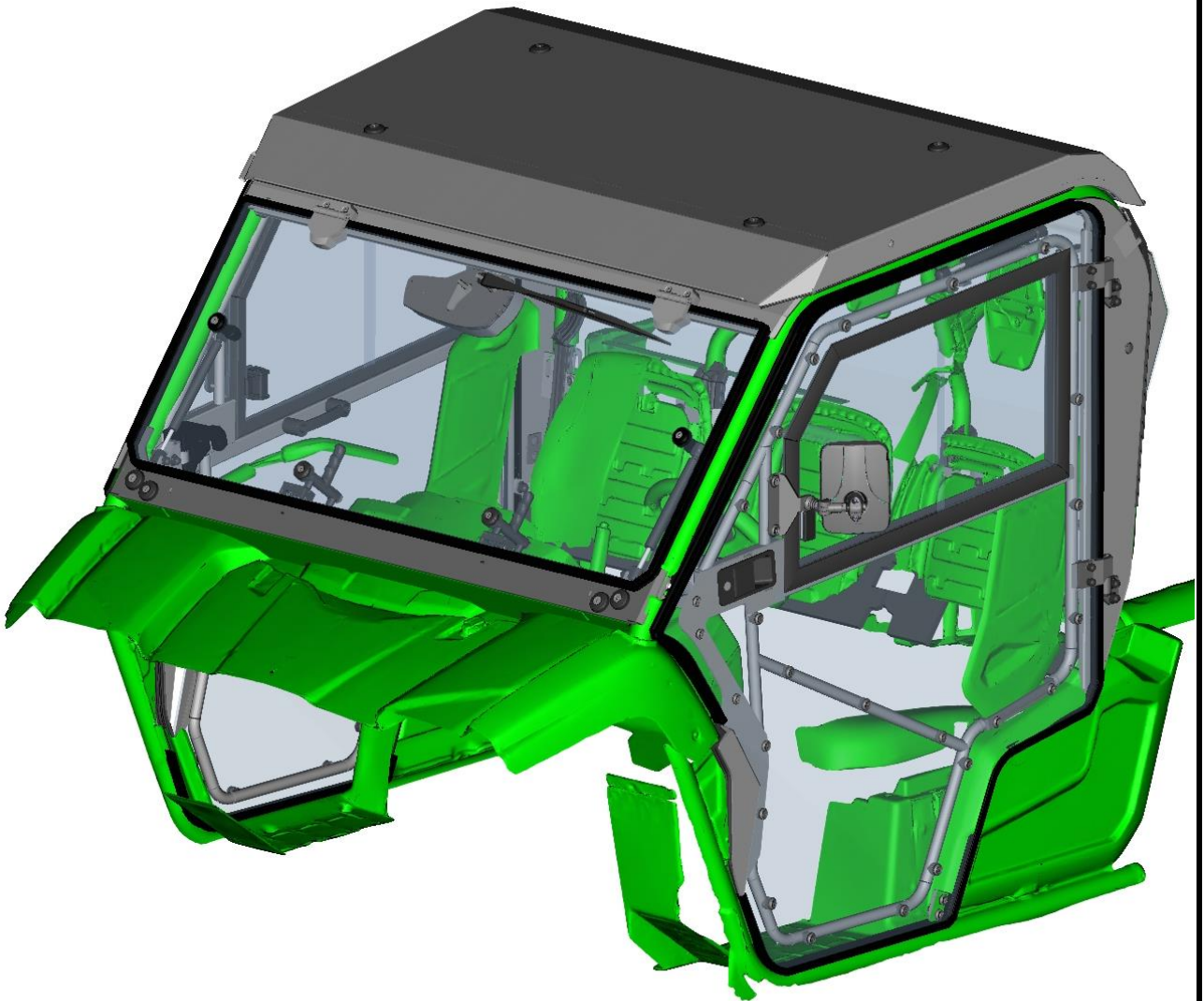

CAB PREVIEW

29

### FRONT PANEL

Loosen the original UTV roll cage fixing assemblies (red circles) and remove the screws from the holes.



30

Place the front bottom ledge holders onto the UTV roll cage in accordance with original holes on both sides.. Attach the front bottom ledge holder with included fixing assemblies. Don't switch the upper and bottom screw.

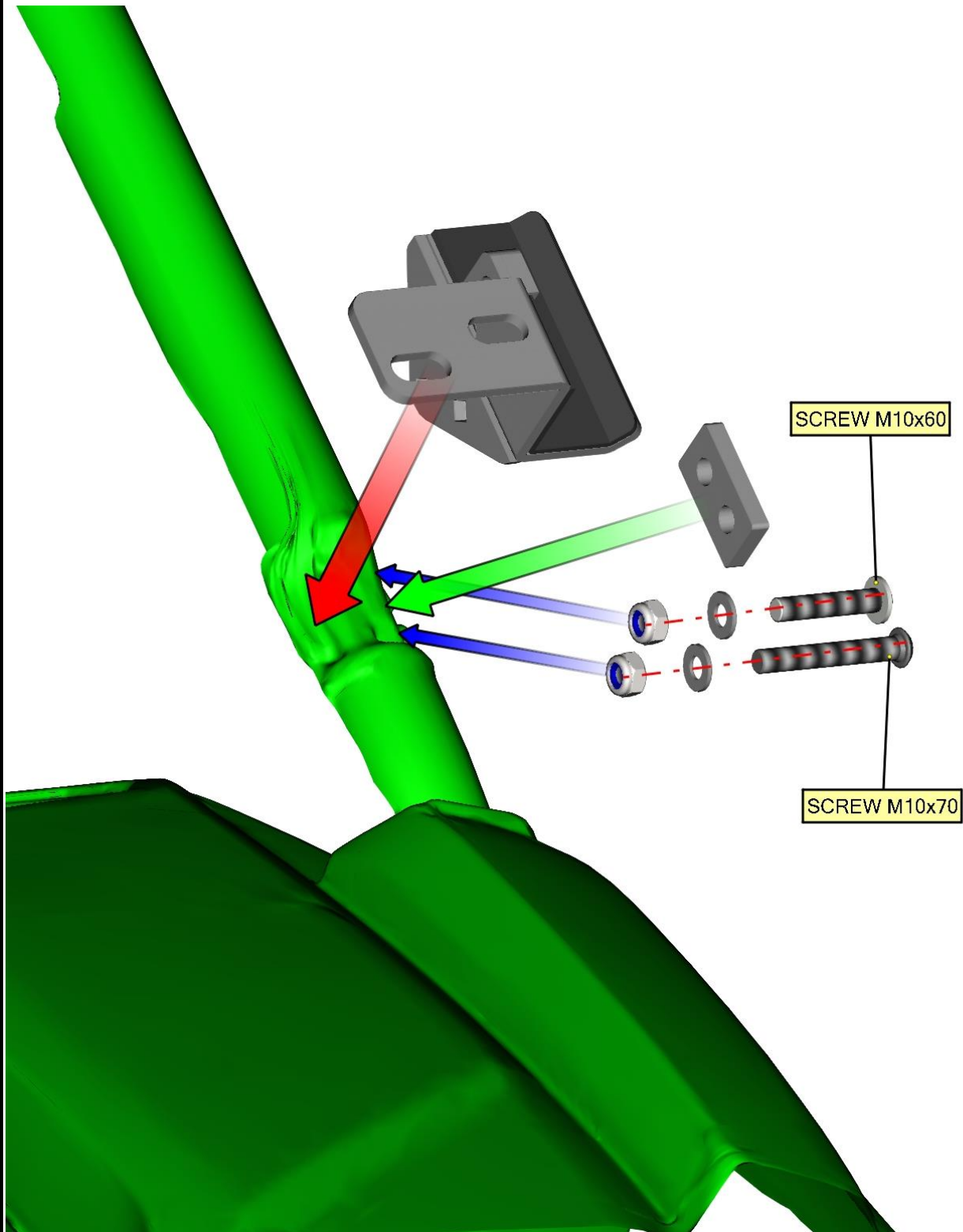

Place the front bottom ledge onto the front bottom ledge holders.

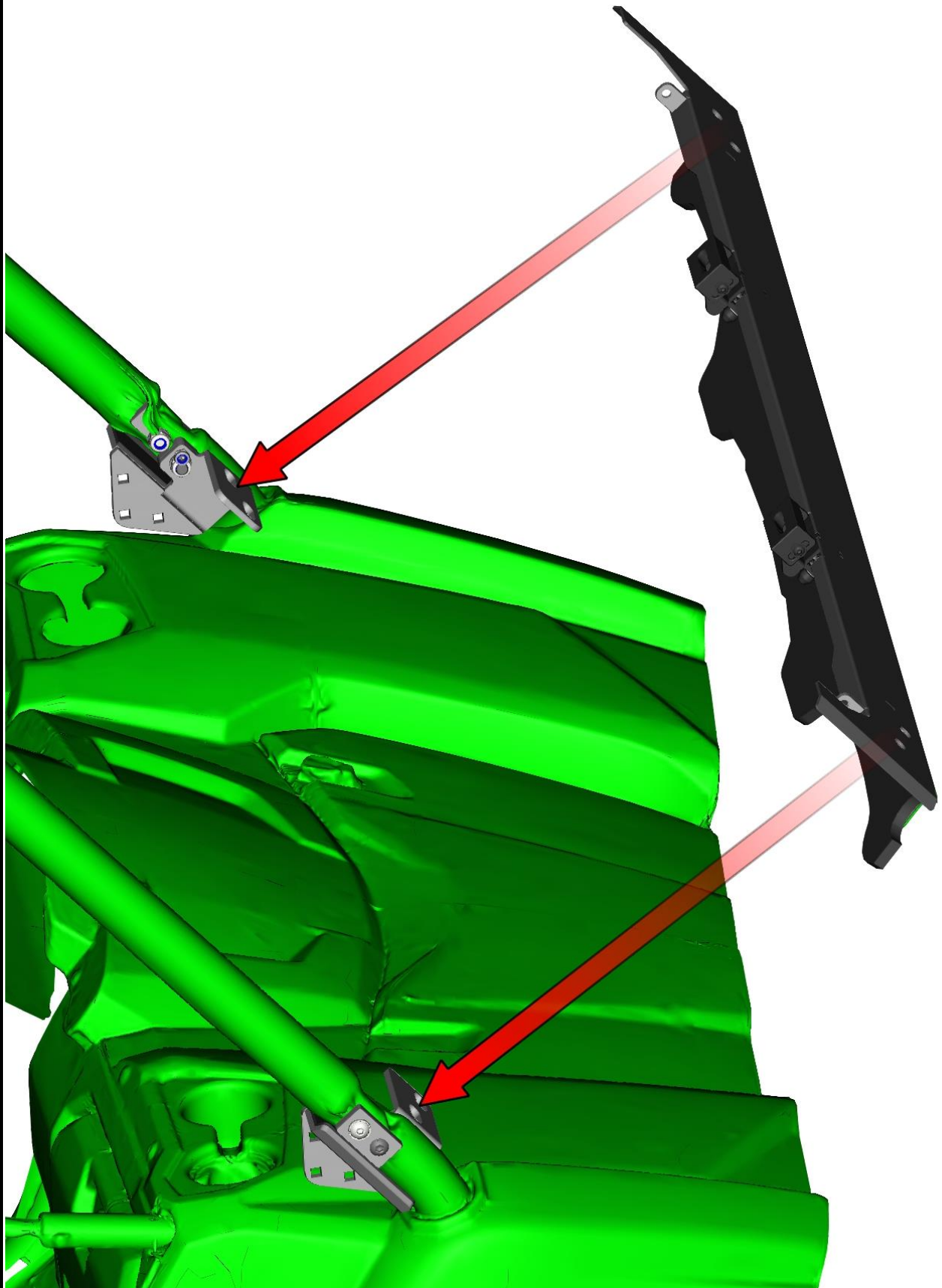

32



Adjust the front bottom ledge to the best position and attach with included fixing assemblies on both sides.

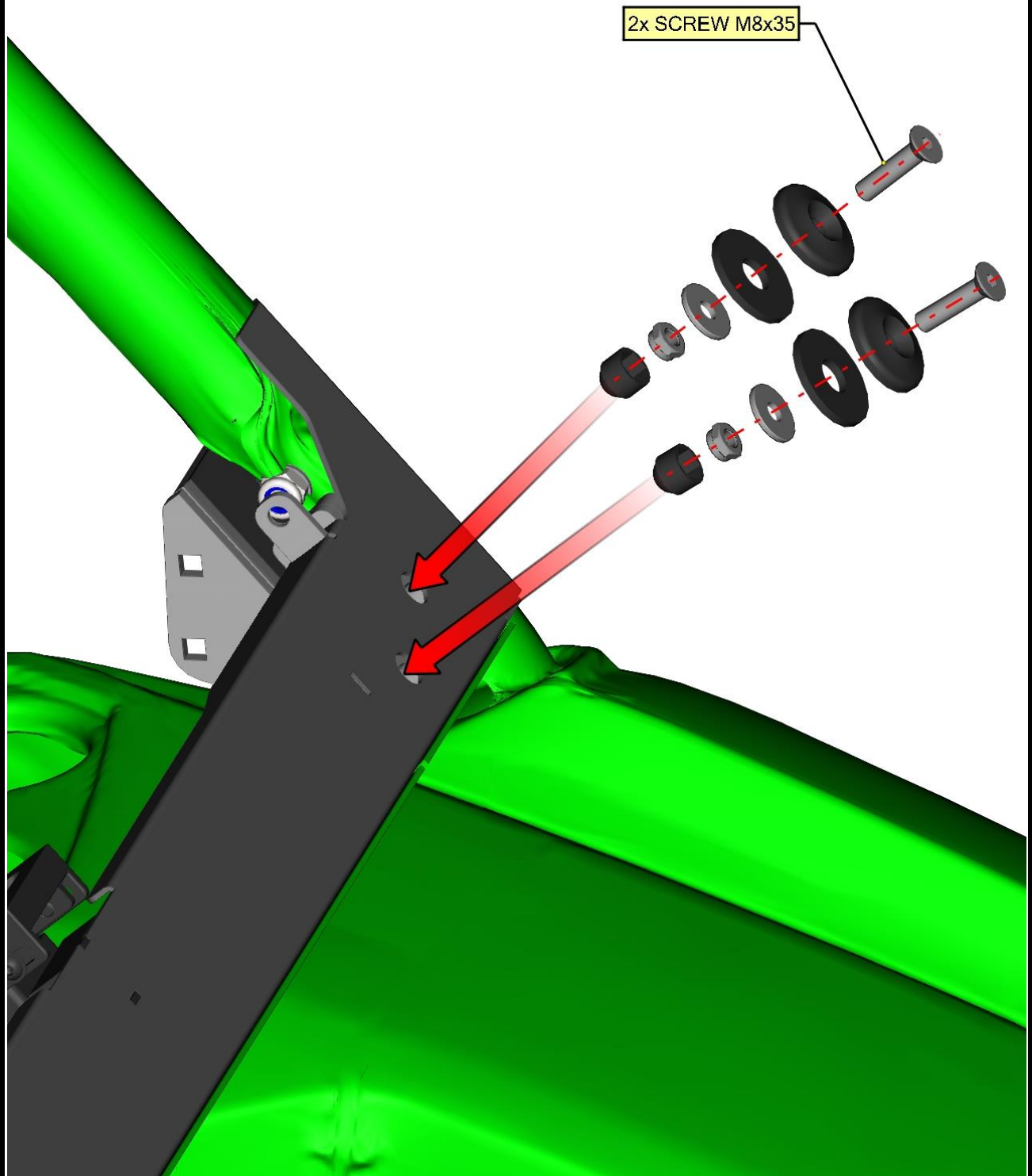

Uninstall original screws from the front upper roller cage reinforcement from both sides, insert 3x washers 10 large and install screws back on both sides.



34

Place the front upper ledge onto the UTV roll cage.

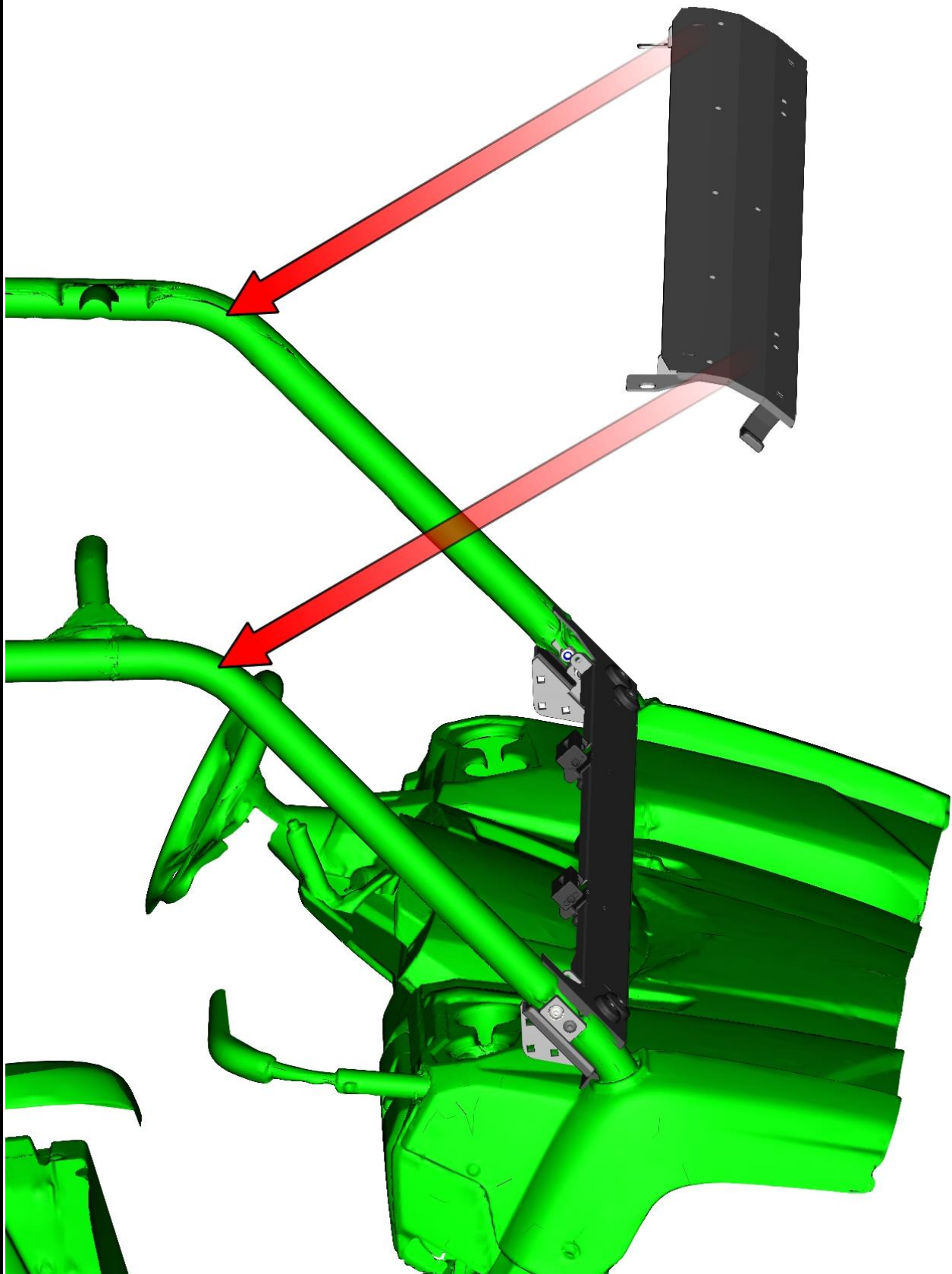

Attach the front upper ledge with included fixing assembly (on both sides). Turn the front upper ledge holder to the correct position and tighten the screw hard (on both sides).

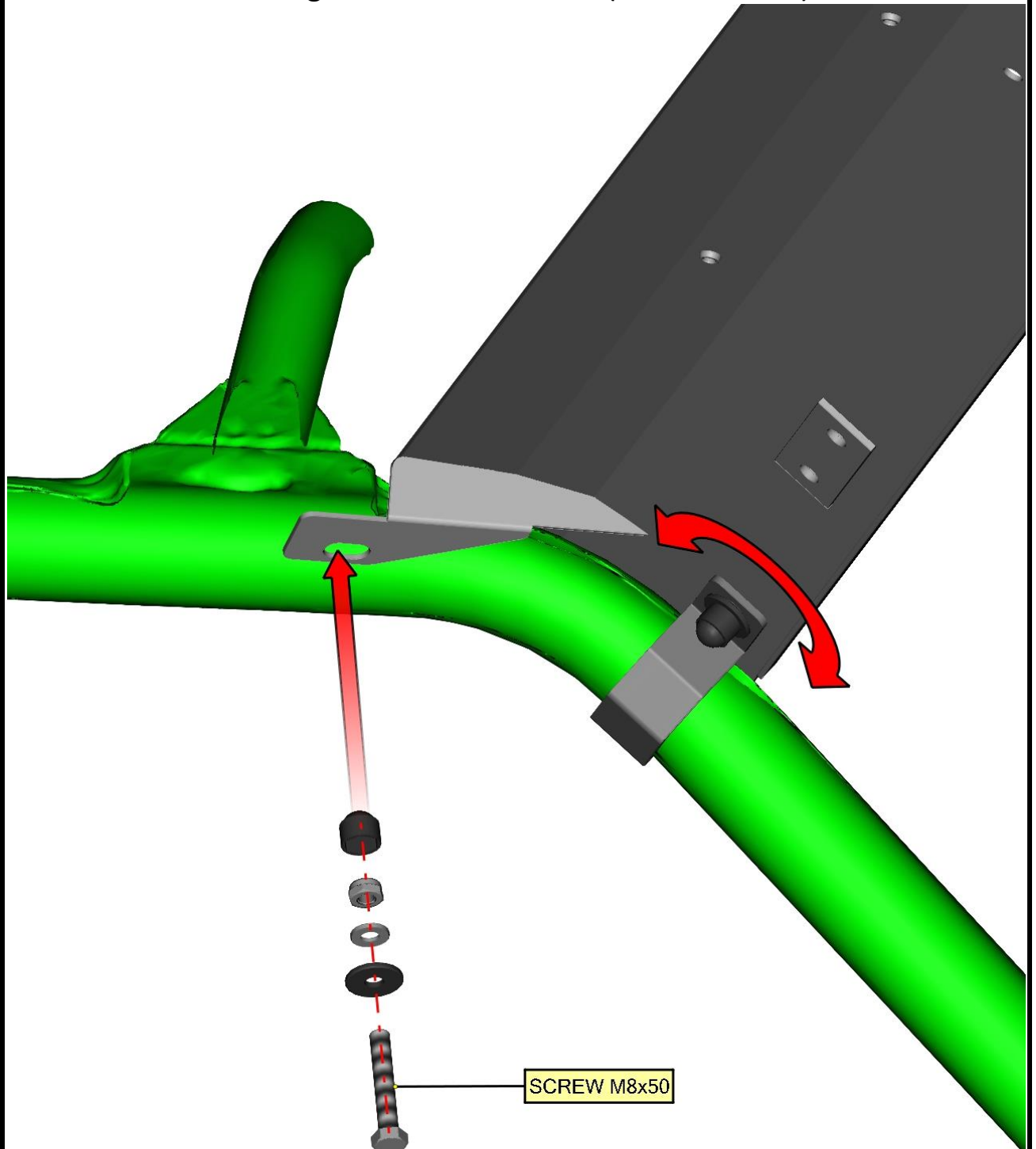

Mount the Windscreen washer tube 90 degree bulkhead joiner onto the front upper ledge.

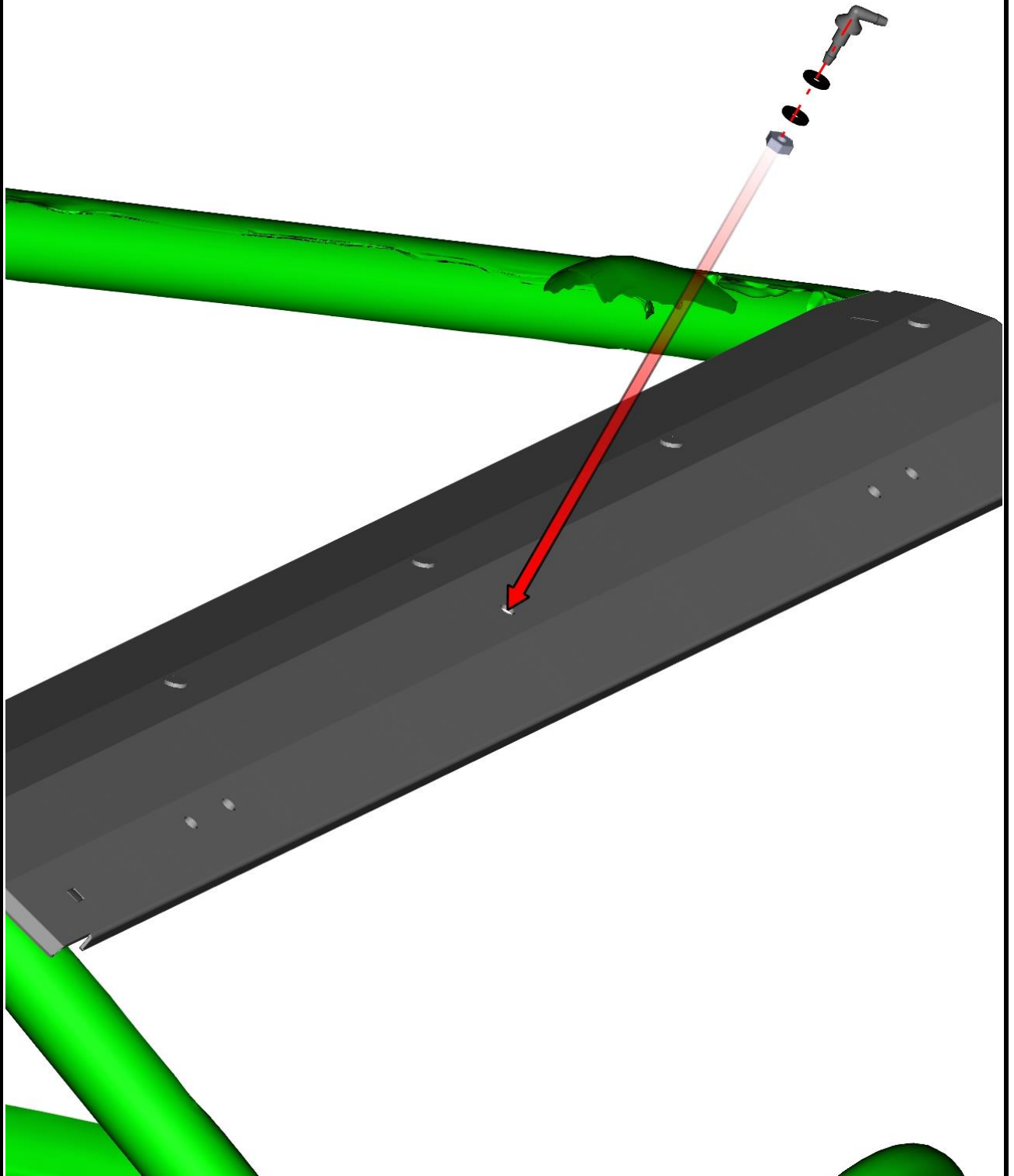

37

Place the front glass assembly onto the front bottom and upper ledge.

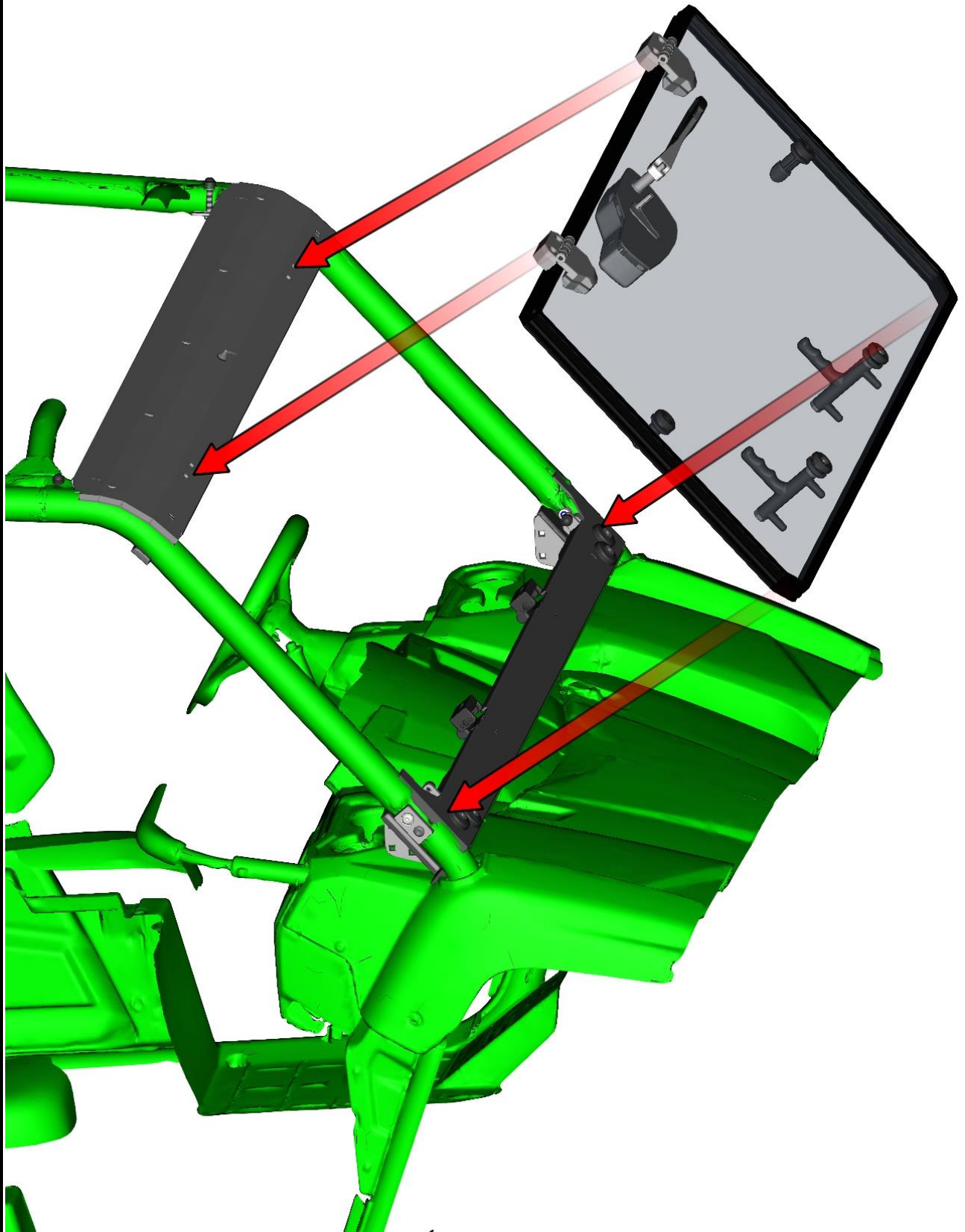

38

Attach the front glass assembly with included screws, nuts, washers and covers on both sides.

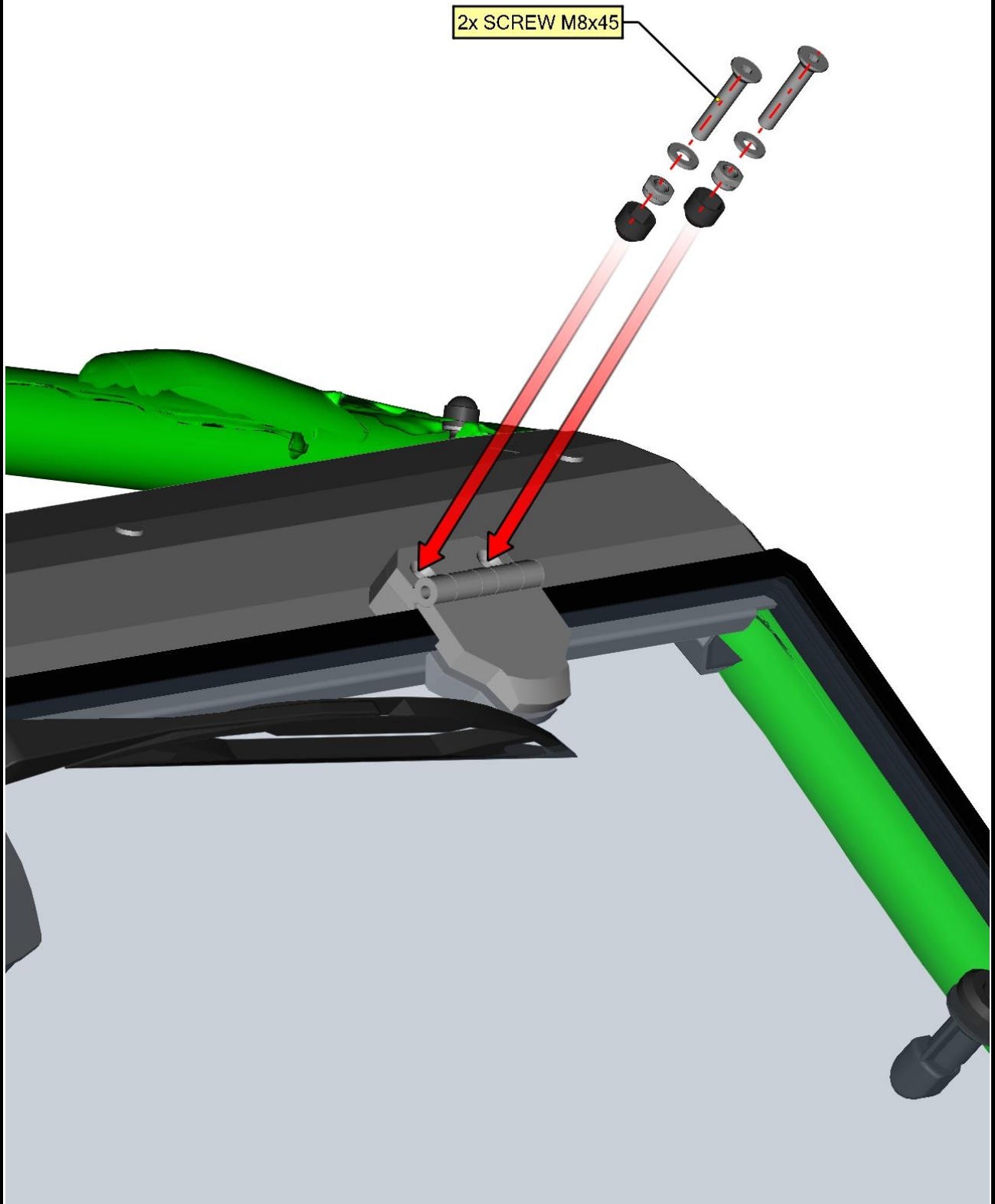

Mount the gas spring pin into the front bottom ledge holder on both sides.

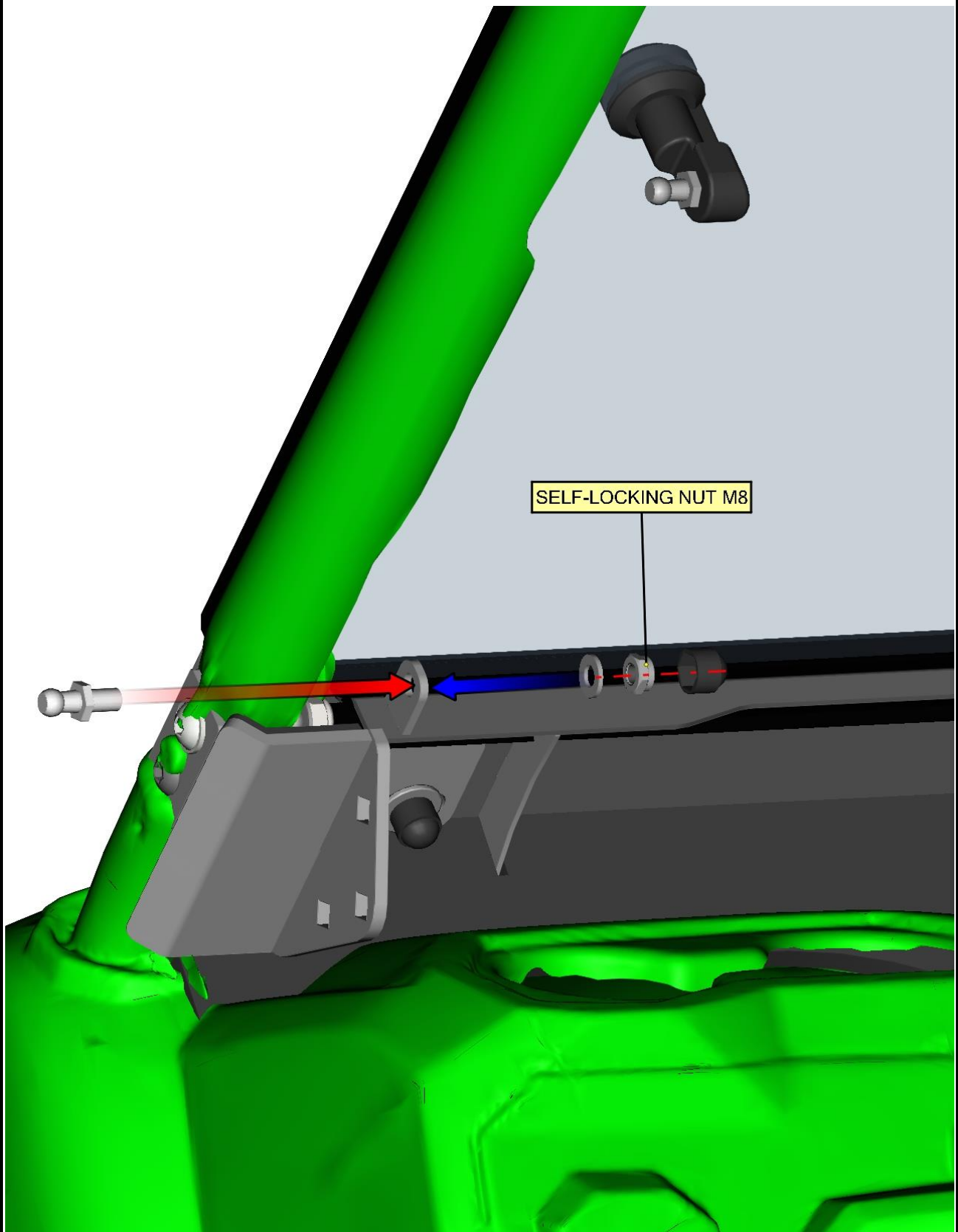

40



Install the gas spring onto the gas spring holders on both sides.  
It's necessary to install the gas springs in same position like on picture.

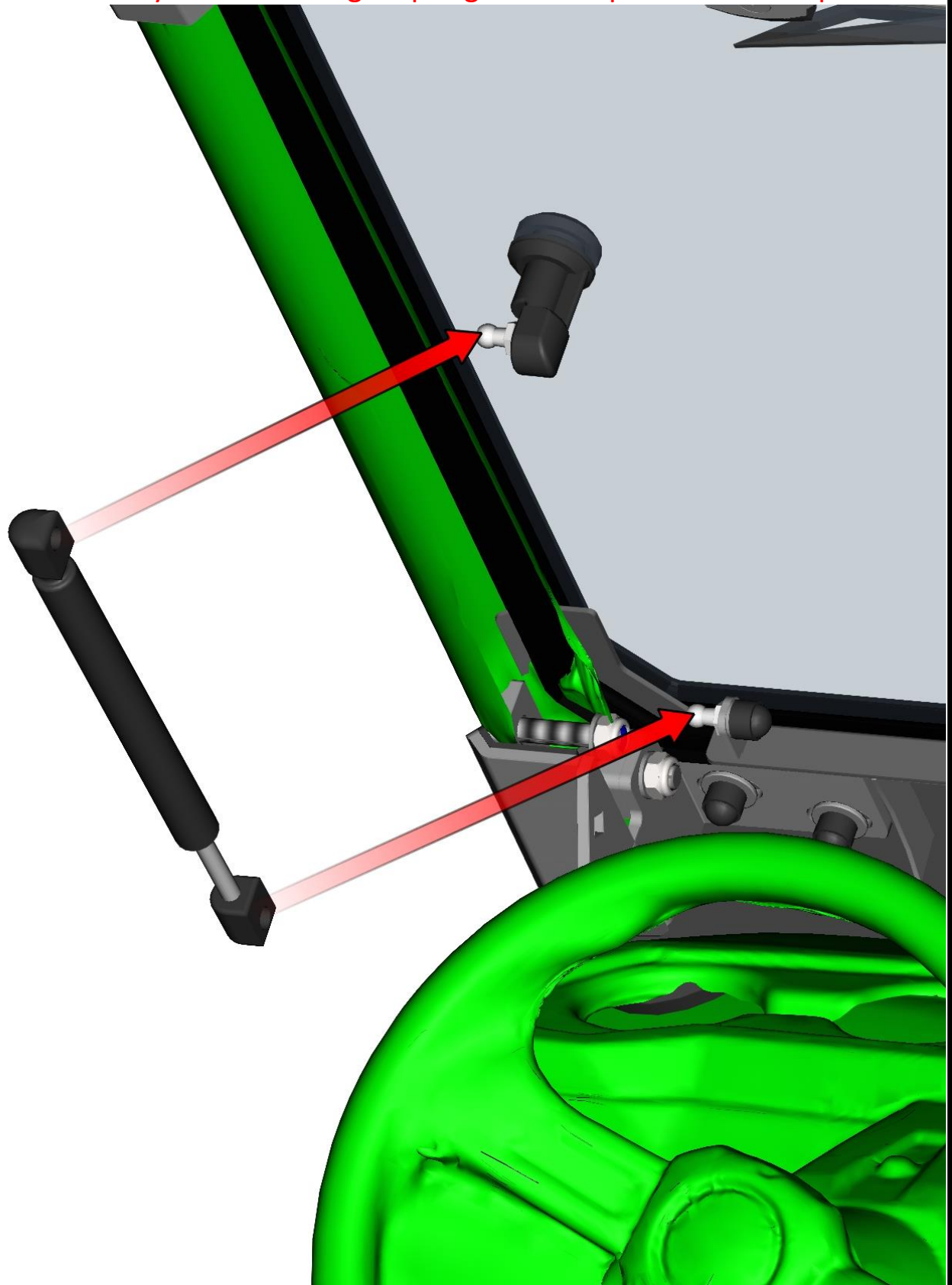

41

### REAR PANEL

If the sound dampening kit was installed. You have to uninstall the sound dampening kit (red rectangle) before the rear panel installation. Loosen the fixing screws and remove the sound dampening panel. Save the fixing assemblies for later usage.

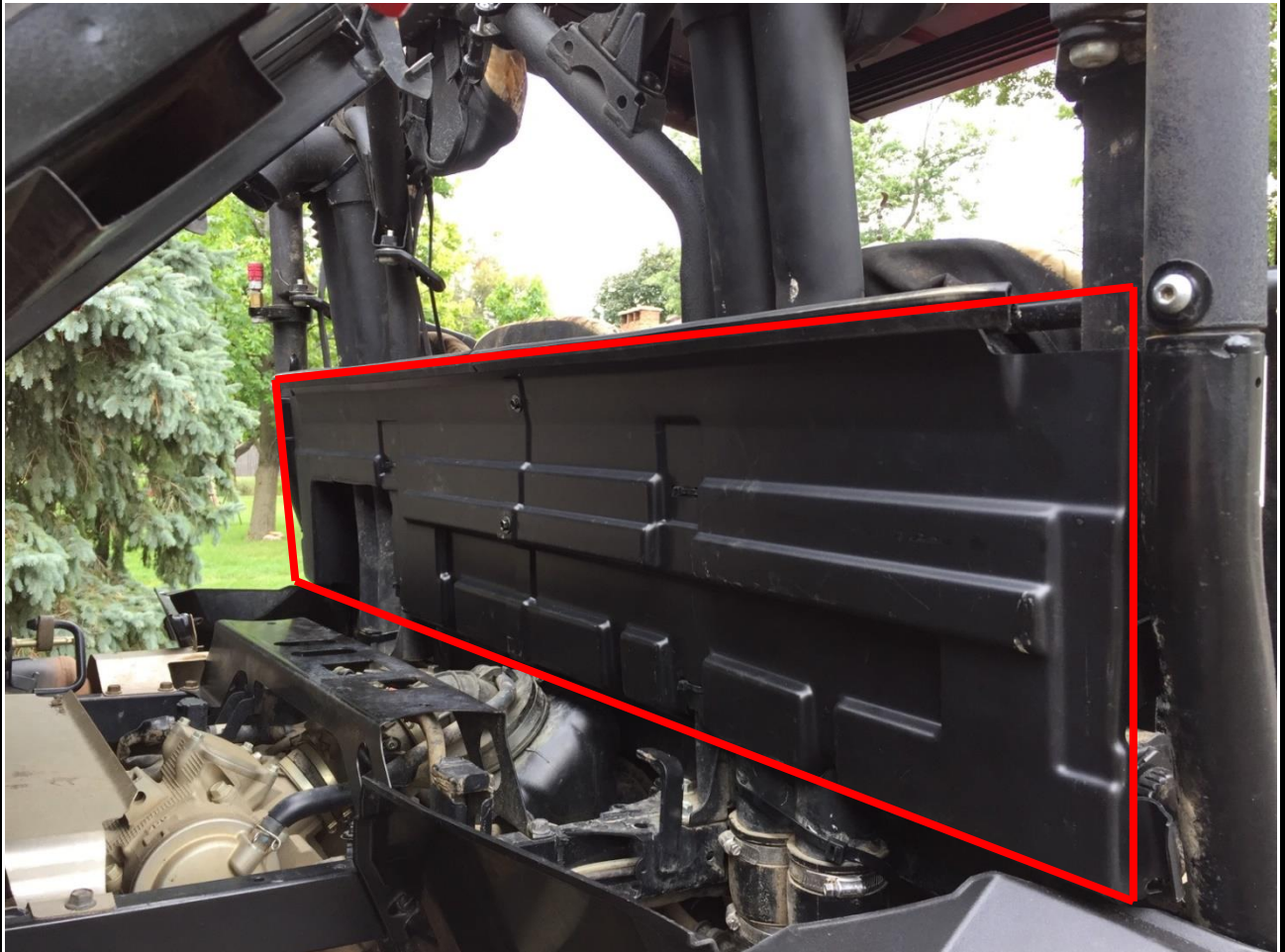

42

Uninstall original screws, washers and nuts from the roller cage on both sides.



43

Place the left door base onto the UTV roll cage.

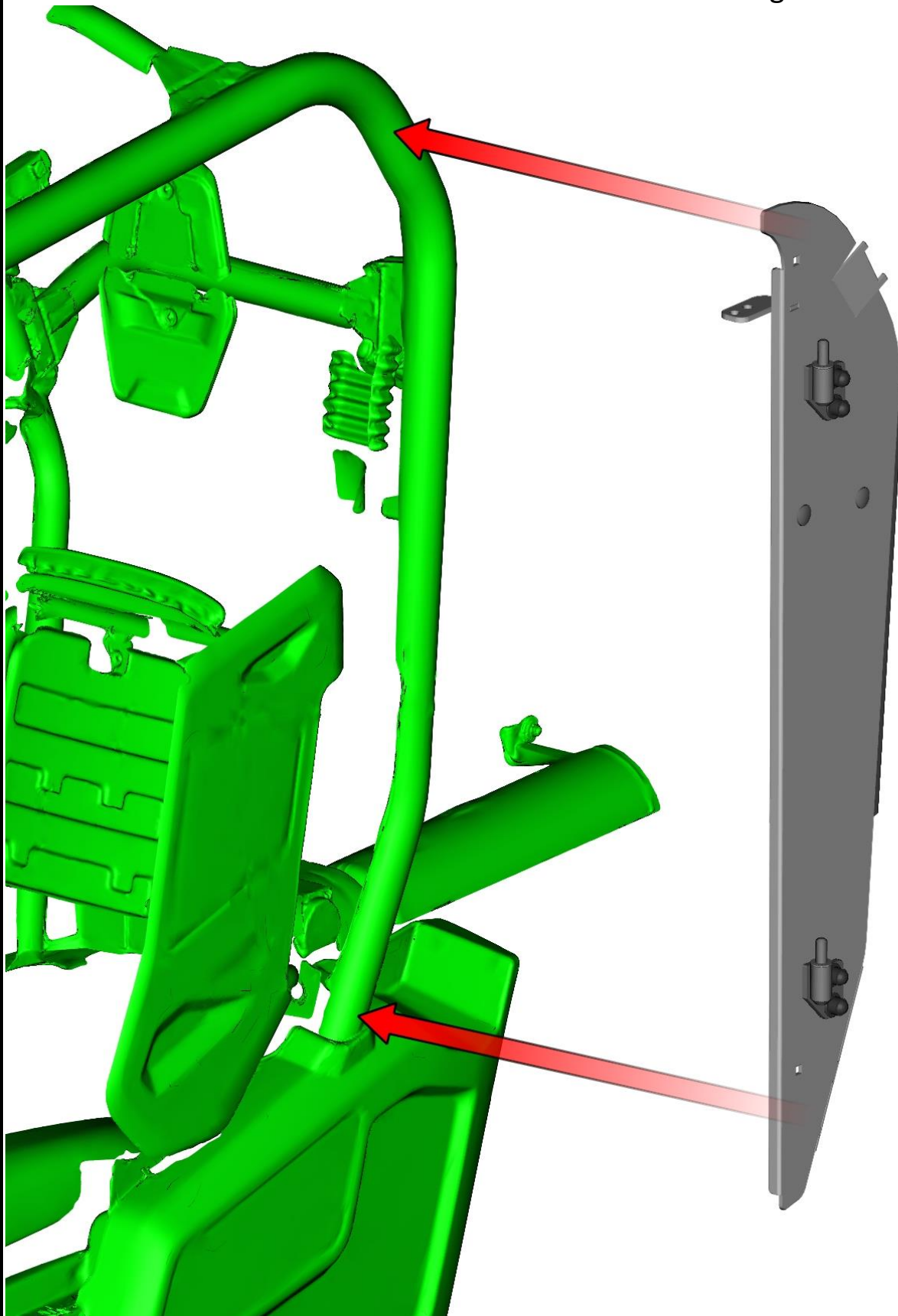

44

Turn the left door base holders to the correct position. Attach the left door base with included fixing assembly.

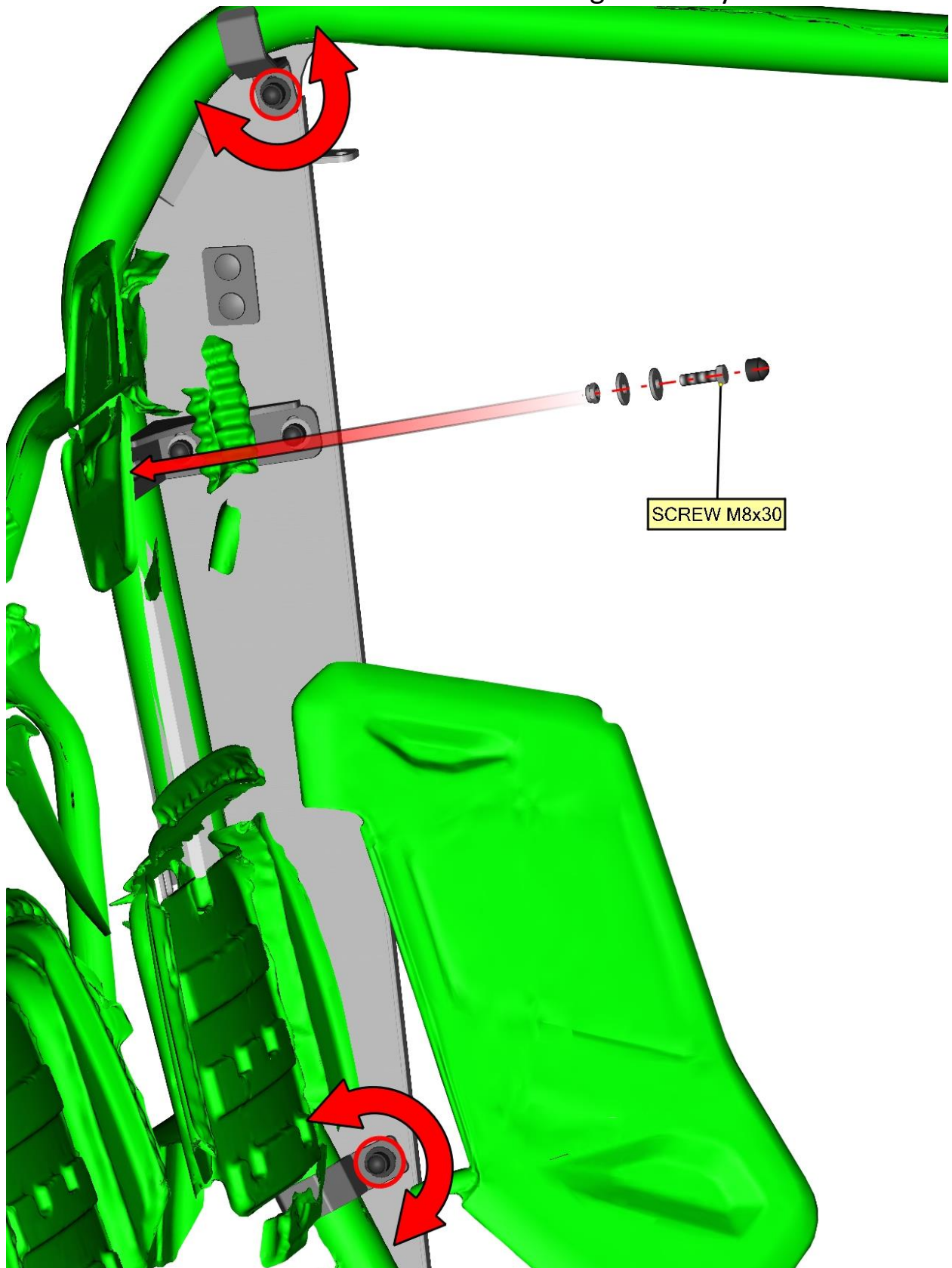

Adjust the left door base to the best position and tighten the holders screws hard.

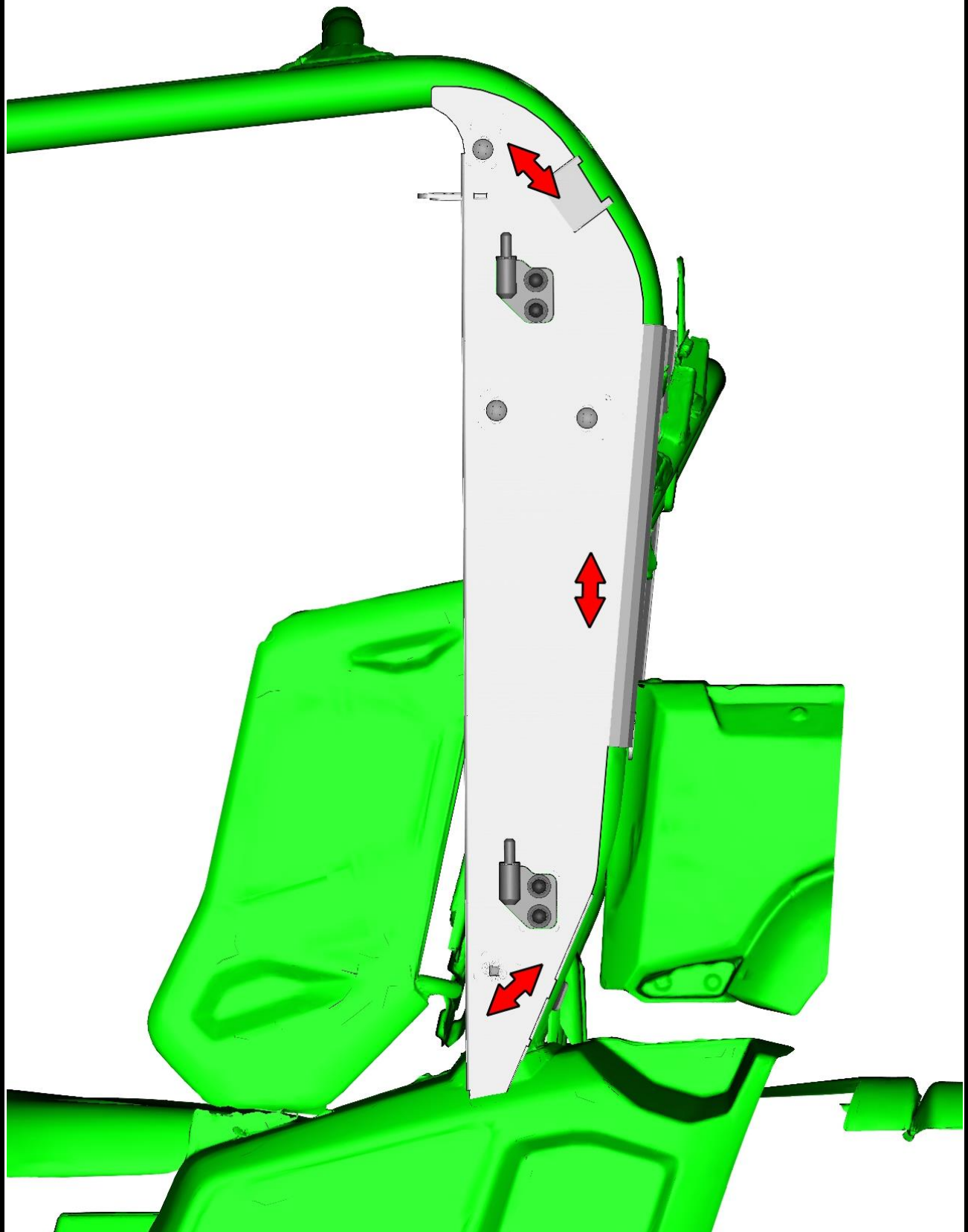

Loosen the rear panel bottom holders screws and remove the bottom holders.

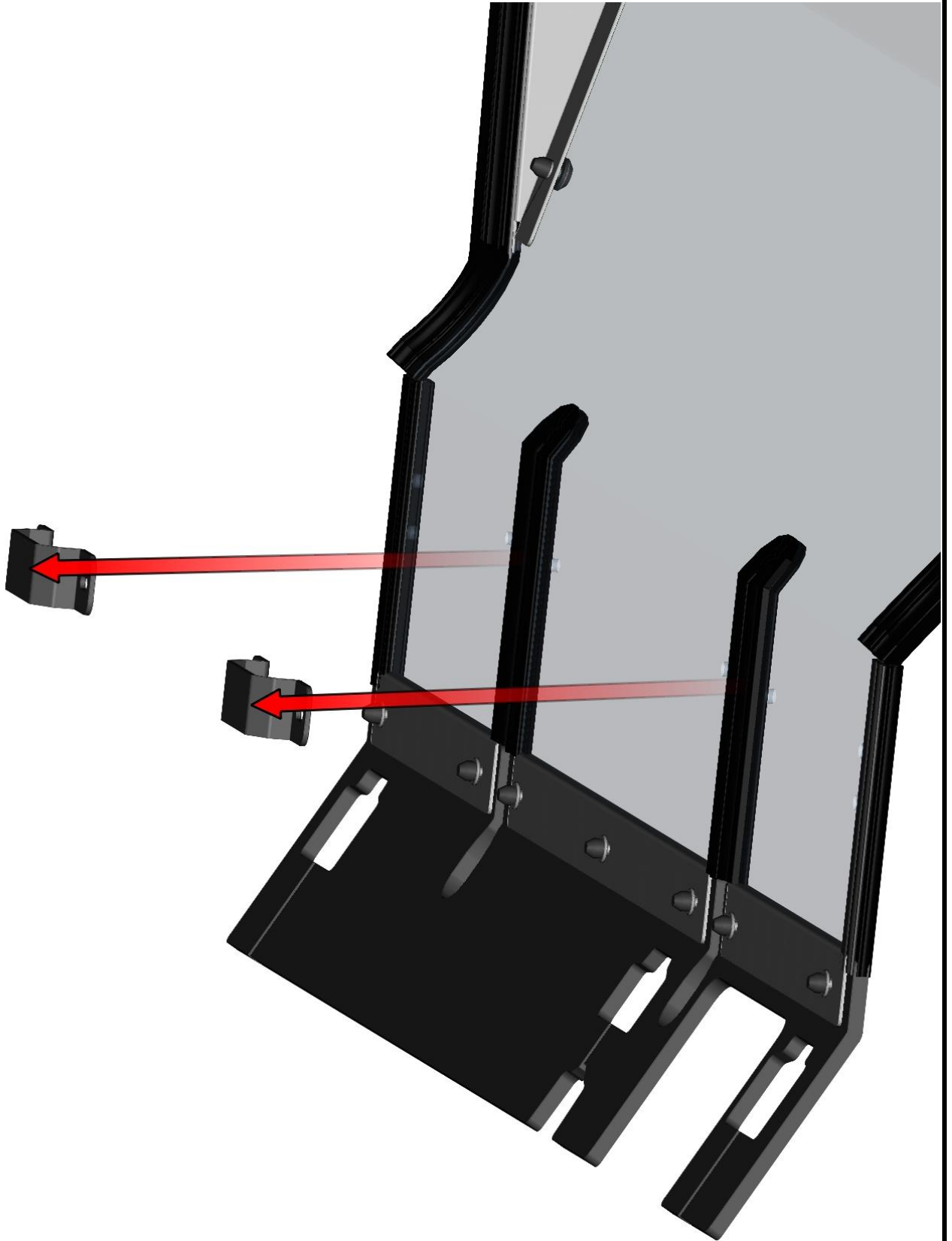

47

Place the rear panel onto the UTV roll cage.

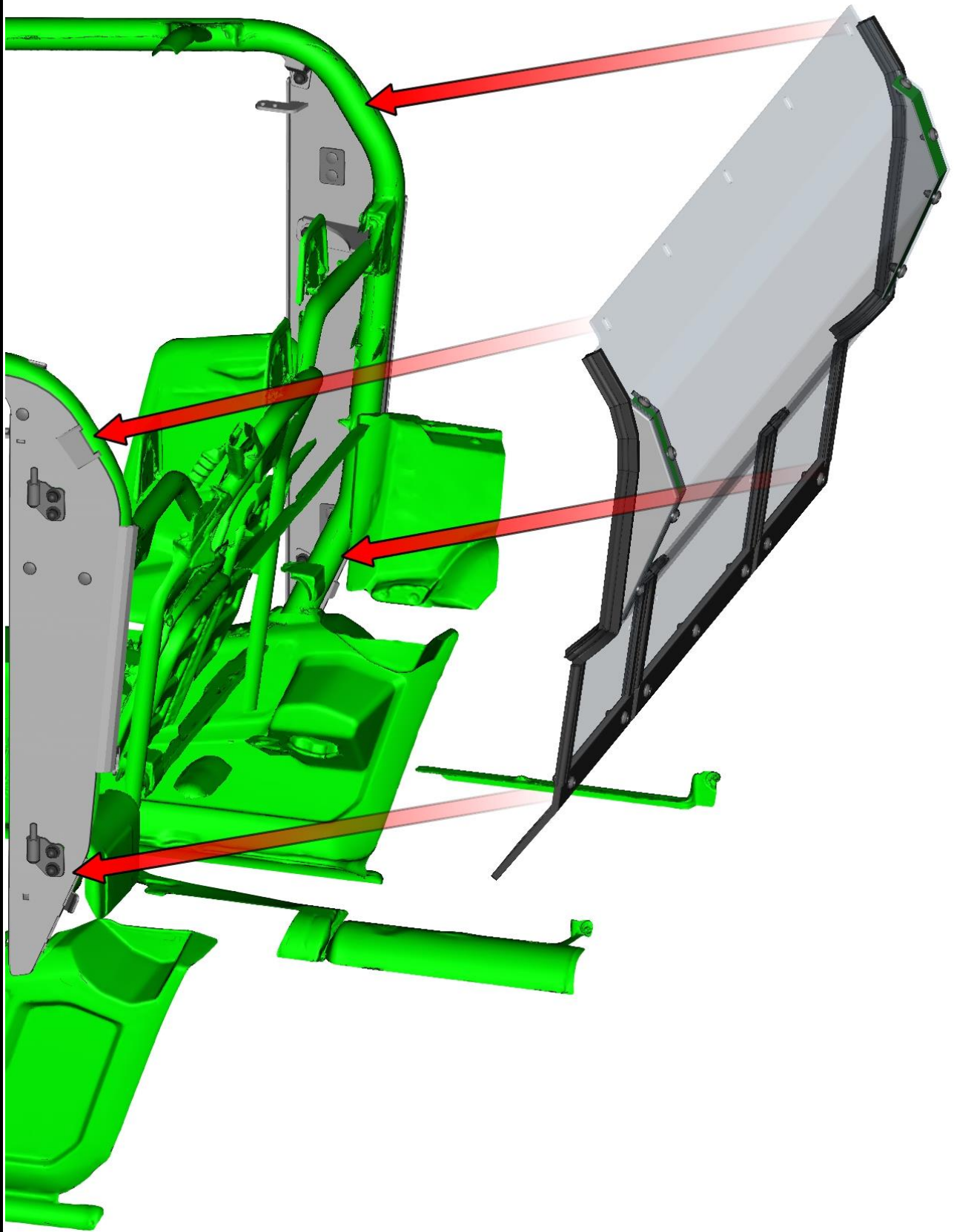

48



Place the rear upper ledge onto the rear polycarbonate in accordance with the holes.

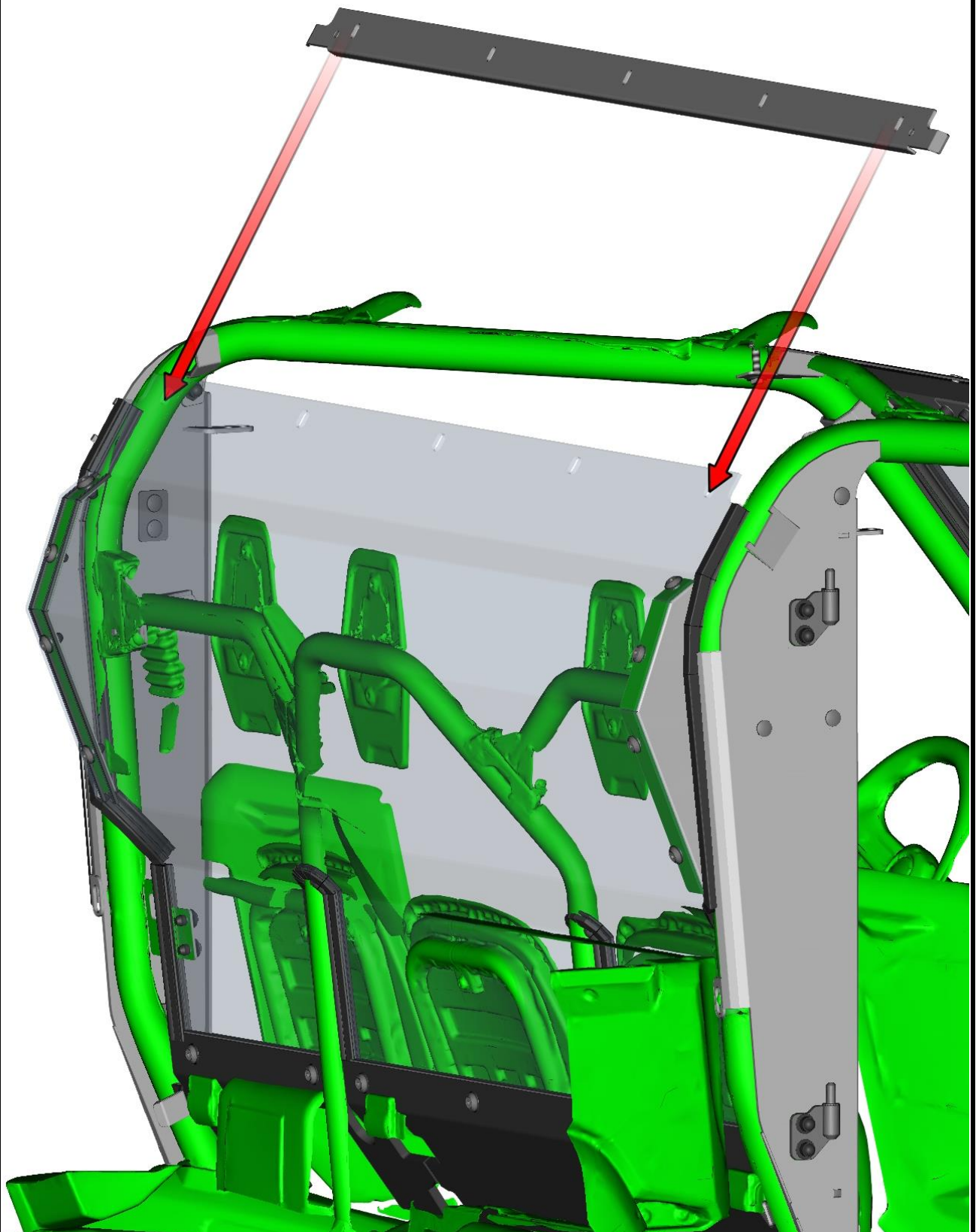

49

Place the left and right rear upper ledge holder onto the rear upper ledge and UTV roll cage.

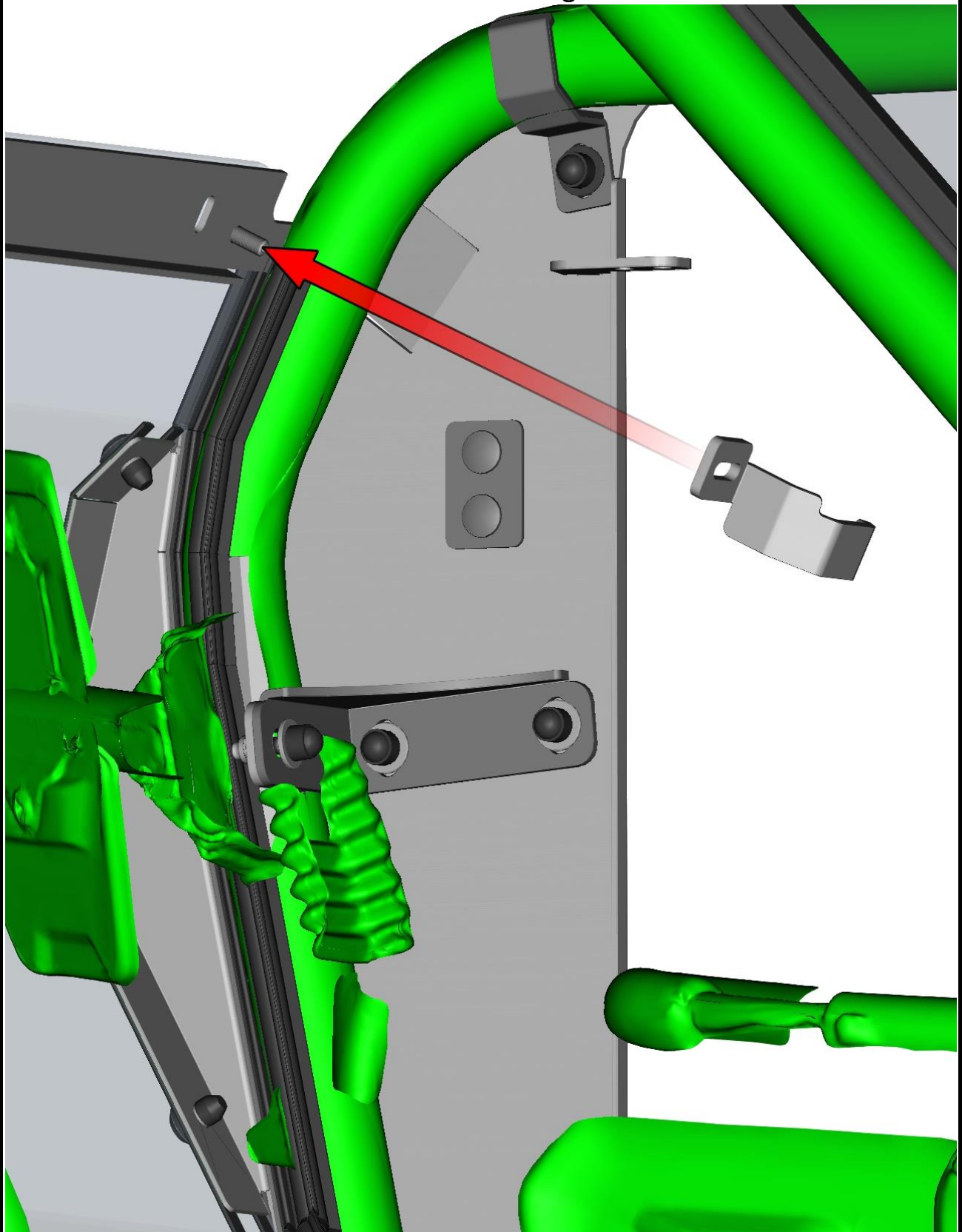

50

Attach the rear upper ledge holder with included fixing assembly (on both sides).

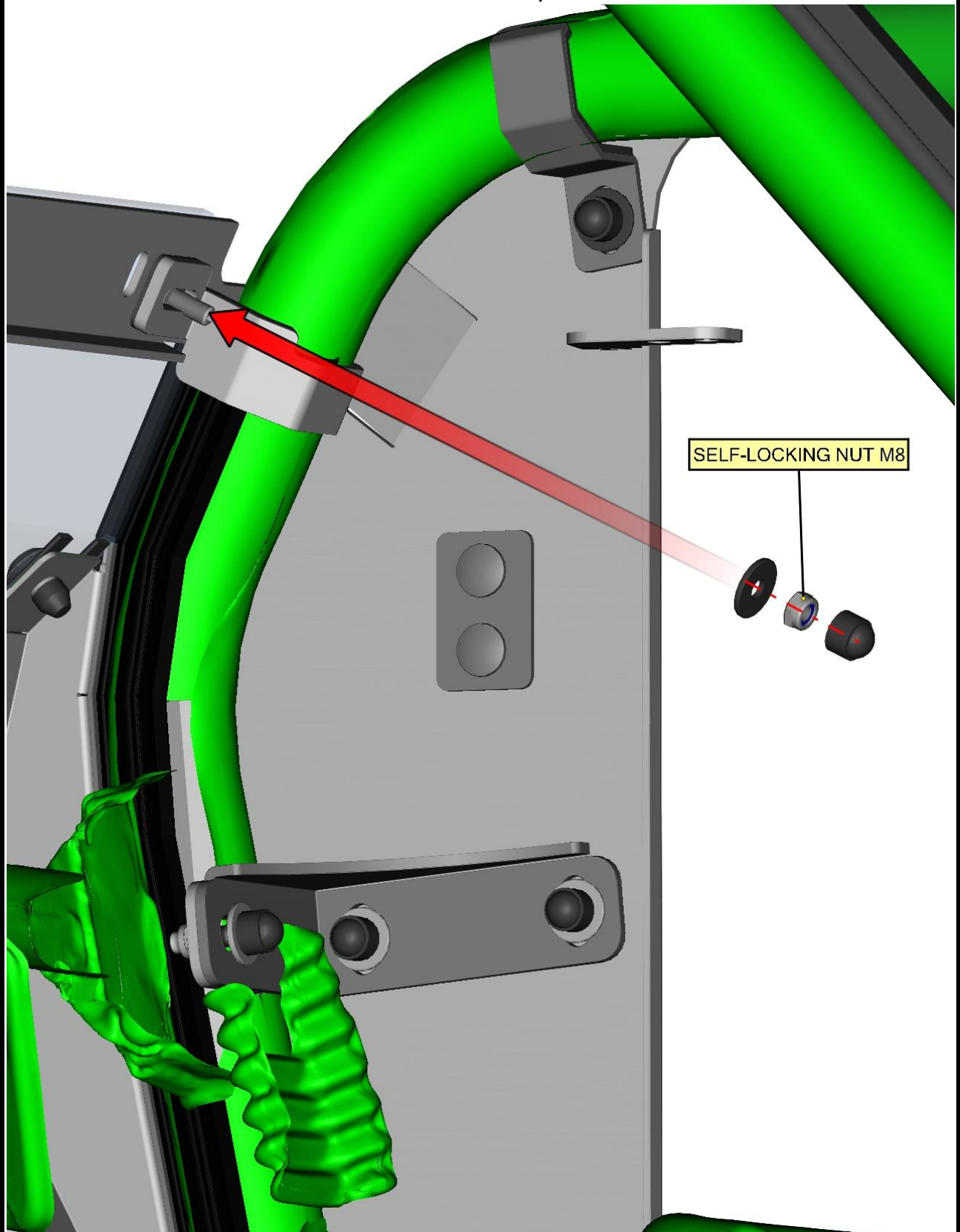

51

Place the rear panel bottom holders onto the rear polycarbonate and the UTV roll cage in accordance with the holes.

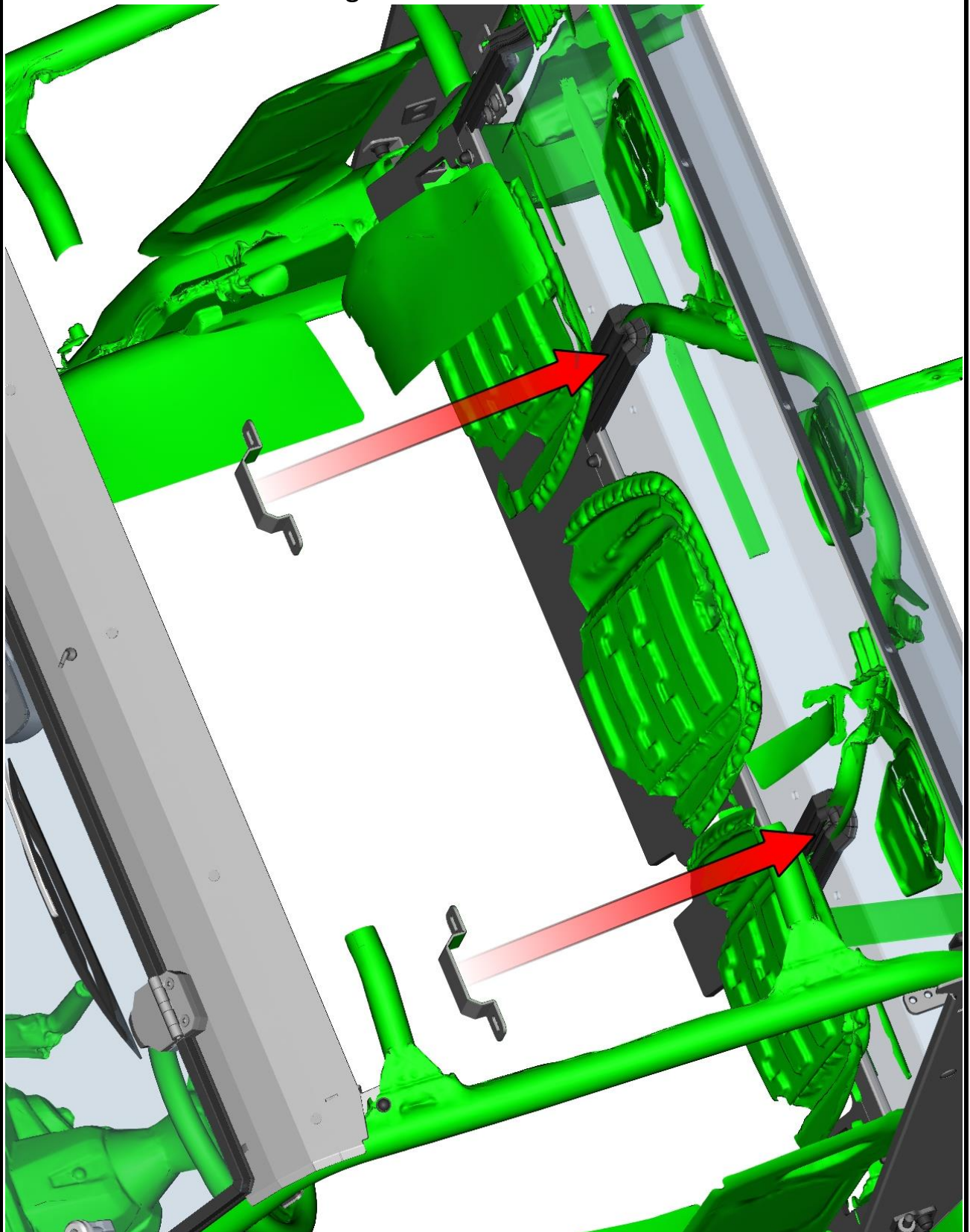

52

Attach the rear panel bottom holders with included fixing assemblies.

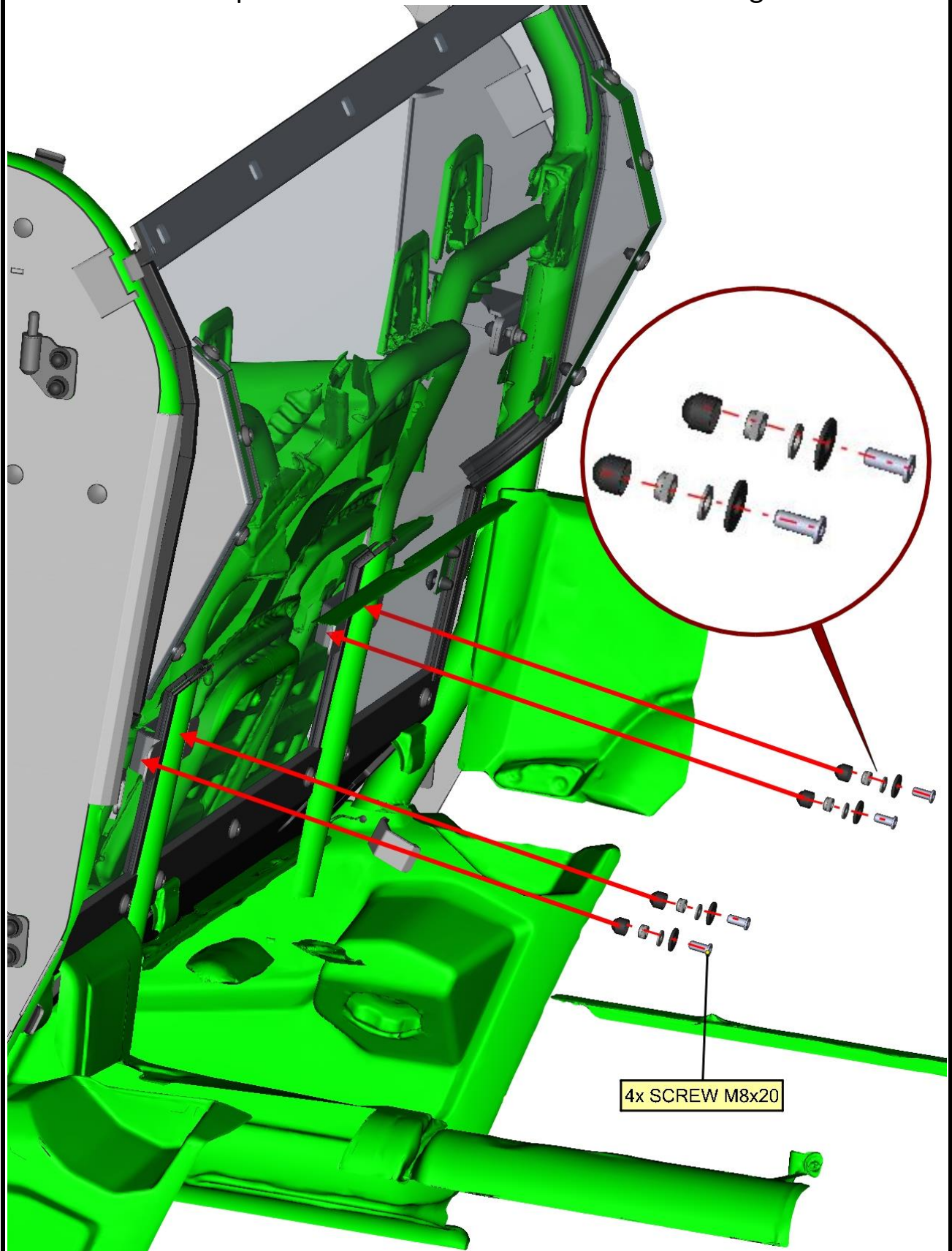

Place the rear panel side holder onto the rear polycarbonate and the UTV roll cage in accordance with the holes (on both sides).

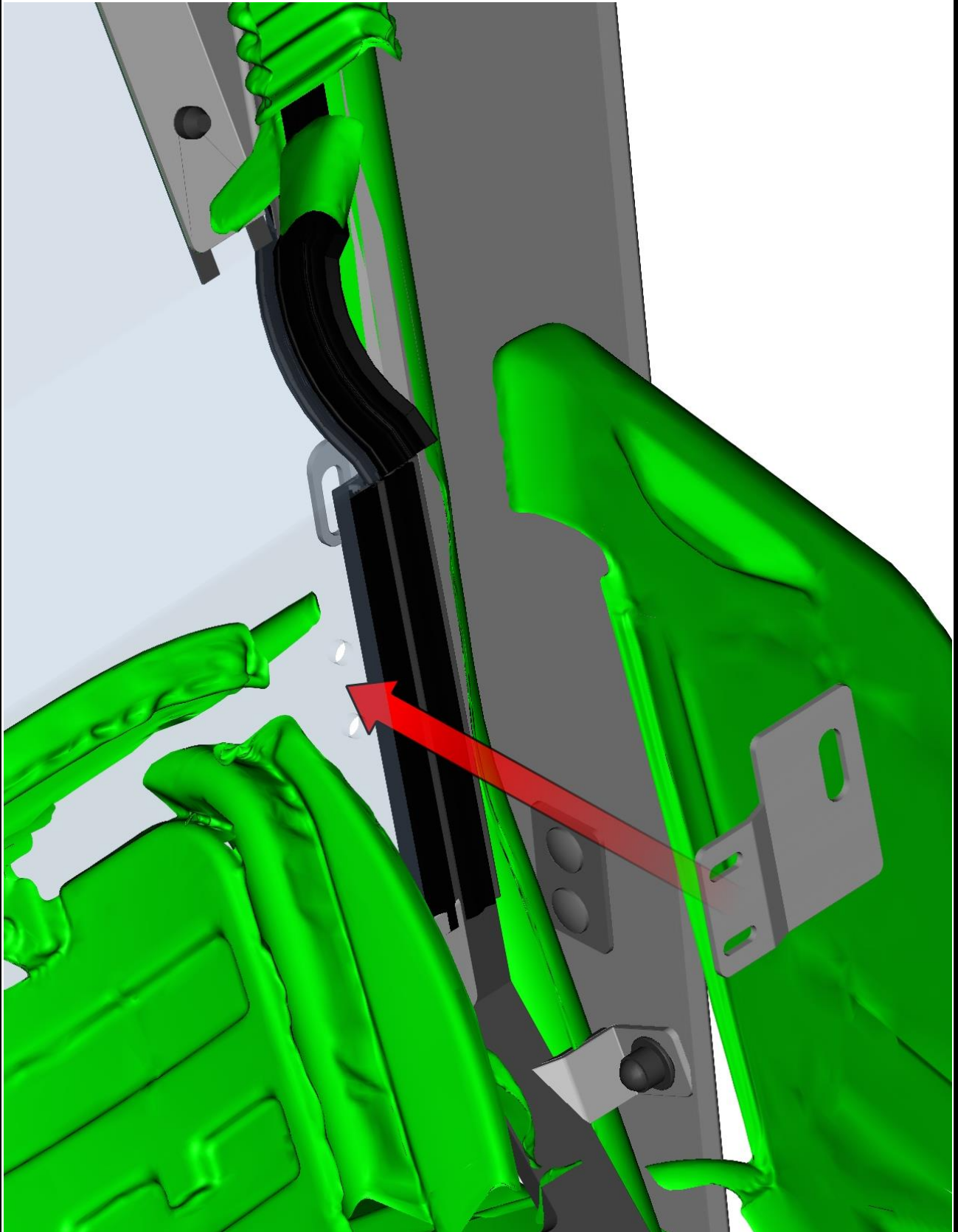

54

Attach the rear panel side holder with included fixing assemblies (on both sides).

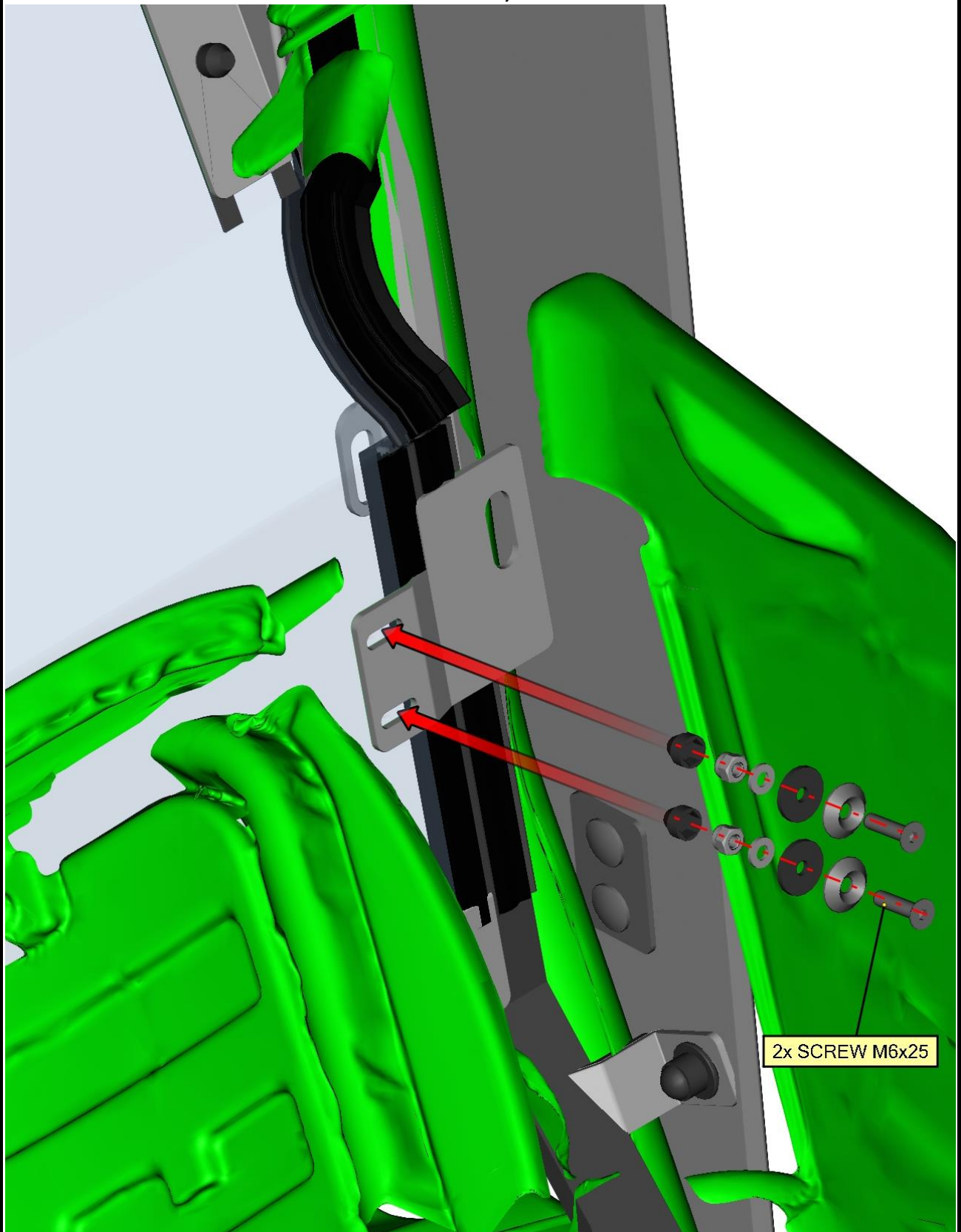

55

Attach the door base and the rear panel with original fixing assembly.



56



### ROOF

Loosen the roof panel holders screws and turn the holders out of the way. Place the roof panel onto the UTV roll cage.

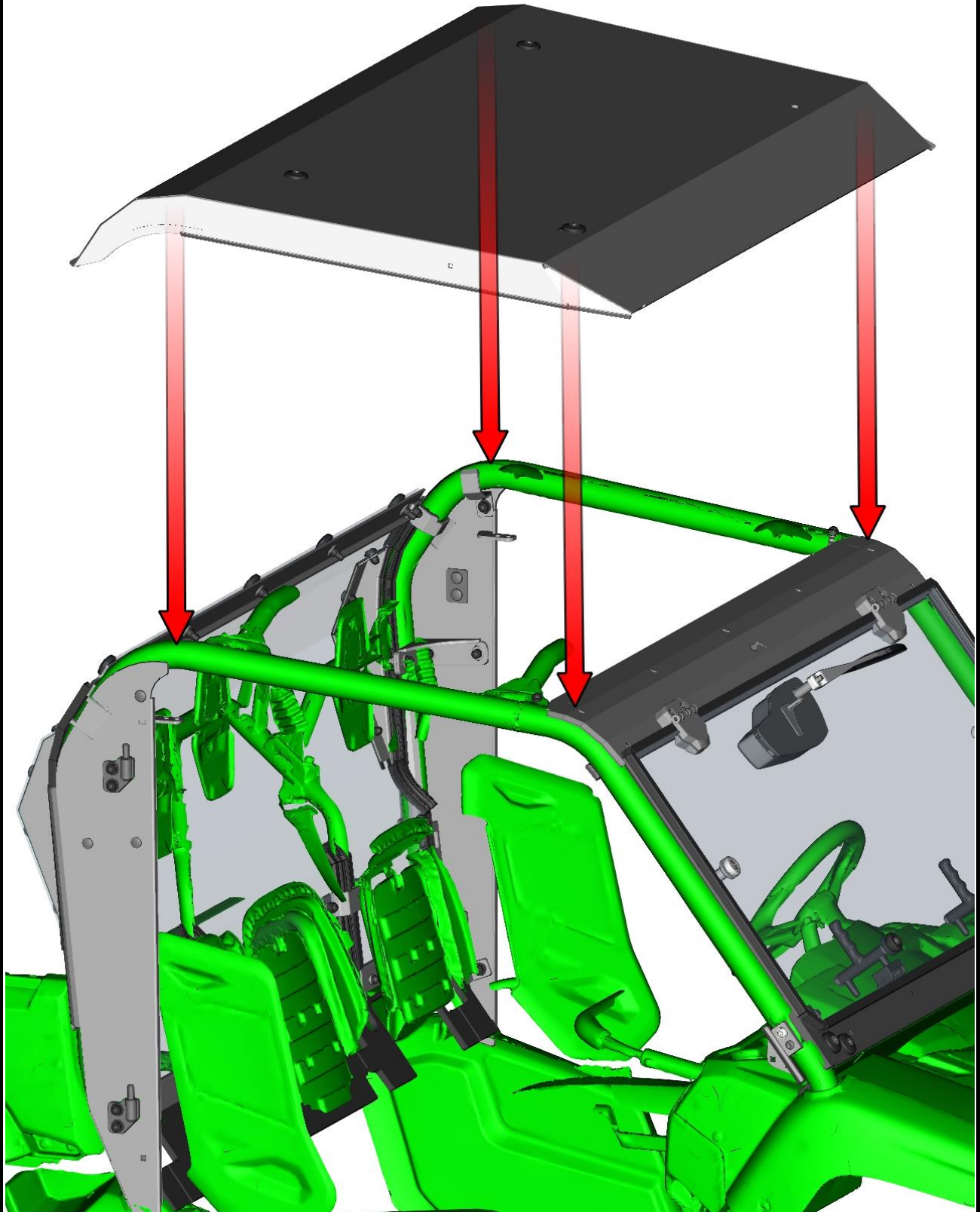

57

Adjust the roof panel to the best position. Turn the roof panel holders to the correct position and tighten the holders screws hard.

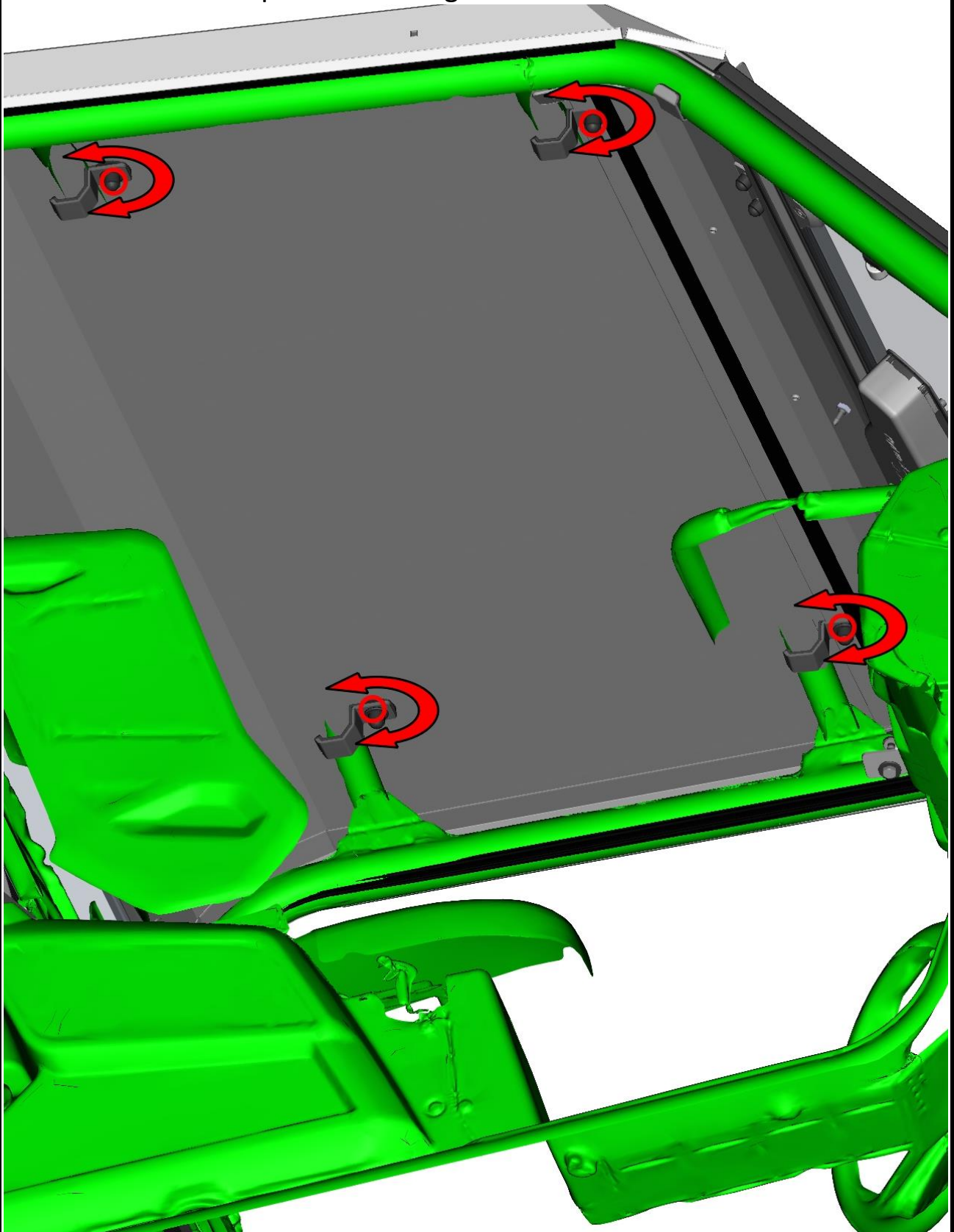

58

Place the roof panel side holder onto the roof panel in accordance with the hole and the UTV roll cage (on both sides).

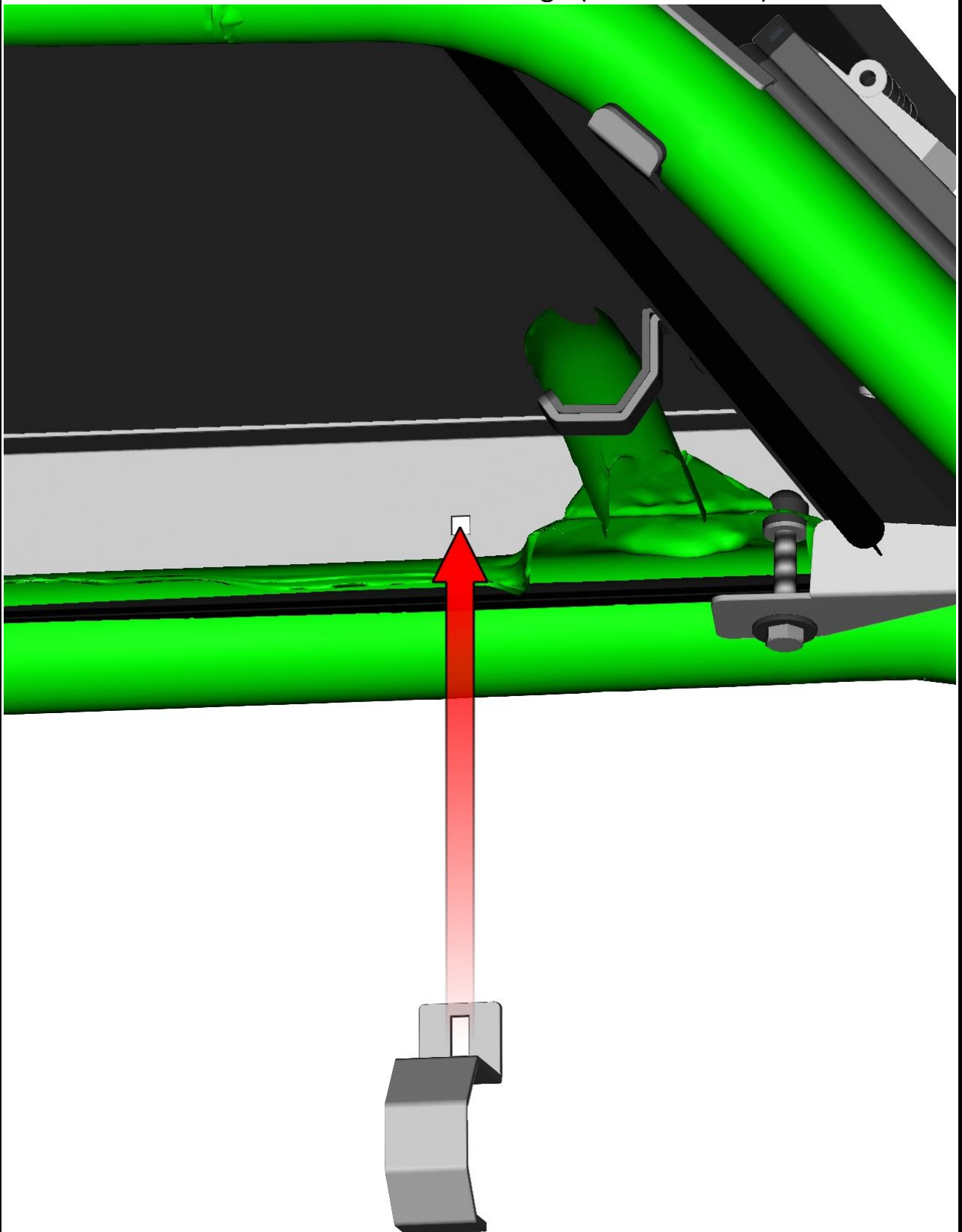

59

Attach the side roof panel holder with included screw, washer and nut on both sides.

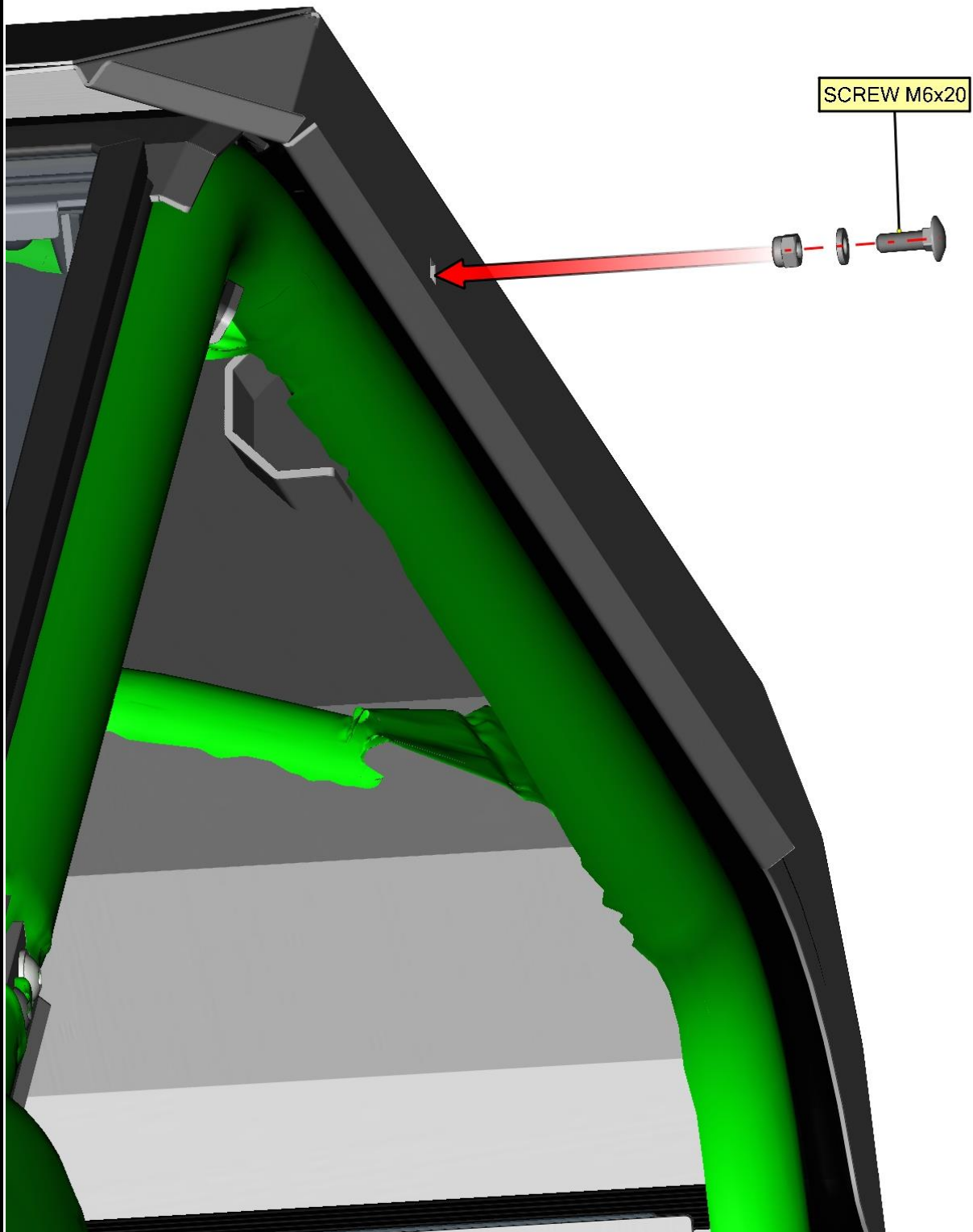

60

Attach the roof panel with included fixing assemblies.

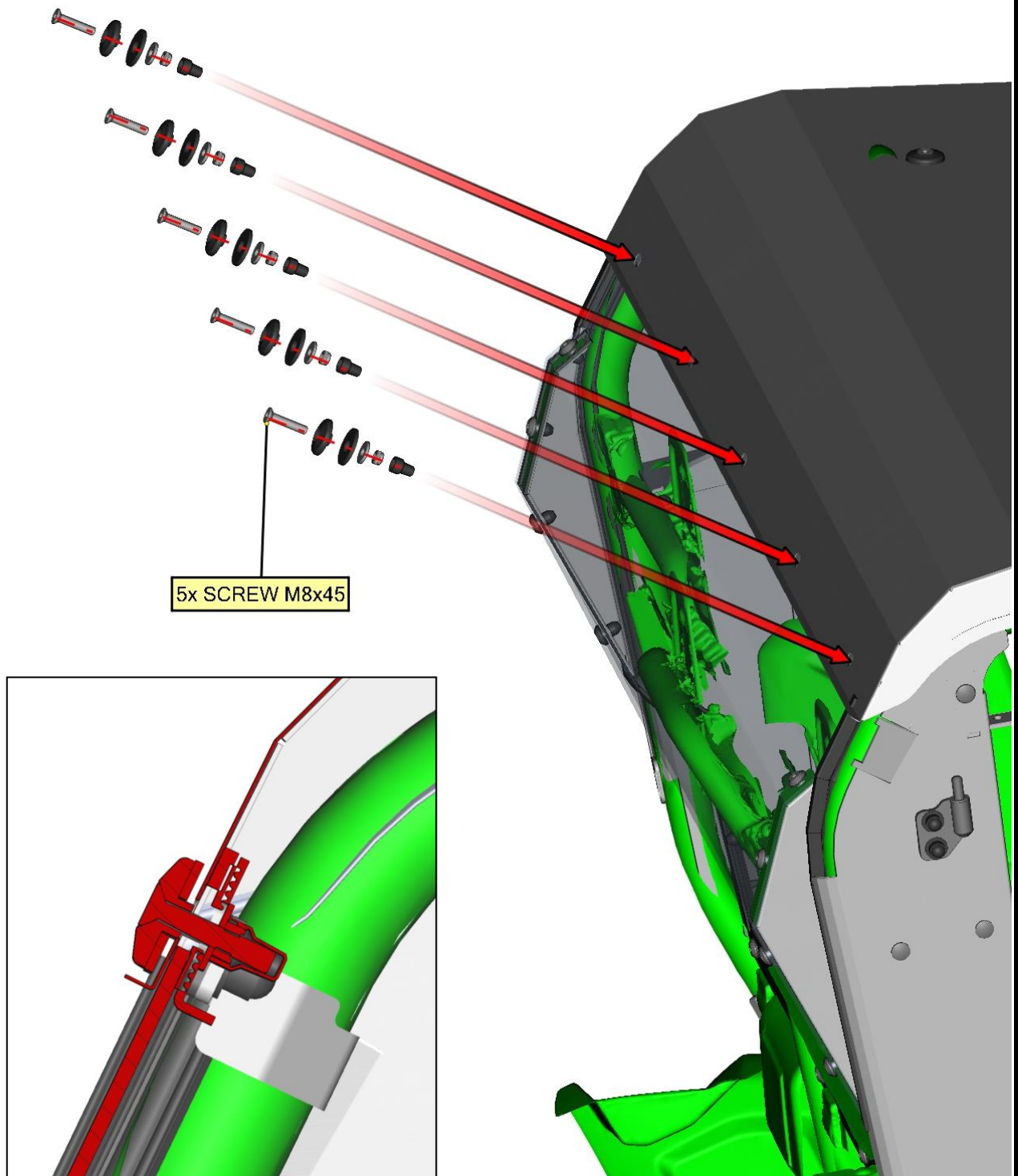

61

**LEFT DOOR + RIGHT DOOR**

Install the washers onto the hinges pins. Lubricate the hinges pins and install the left door onto the hinges pins.

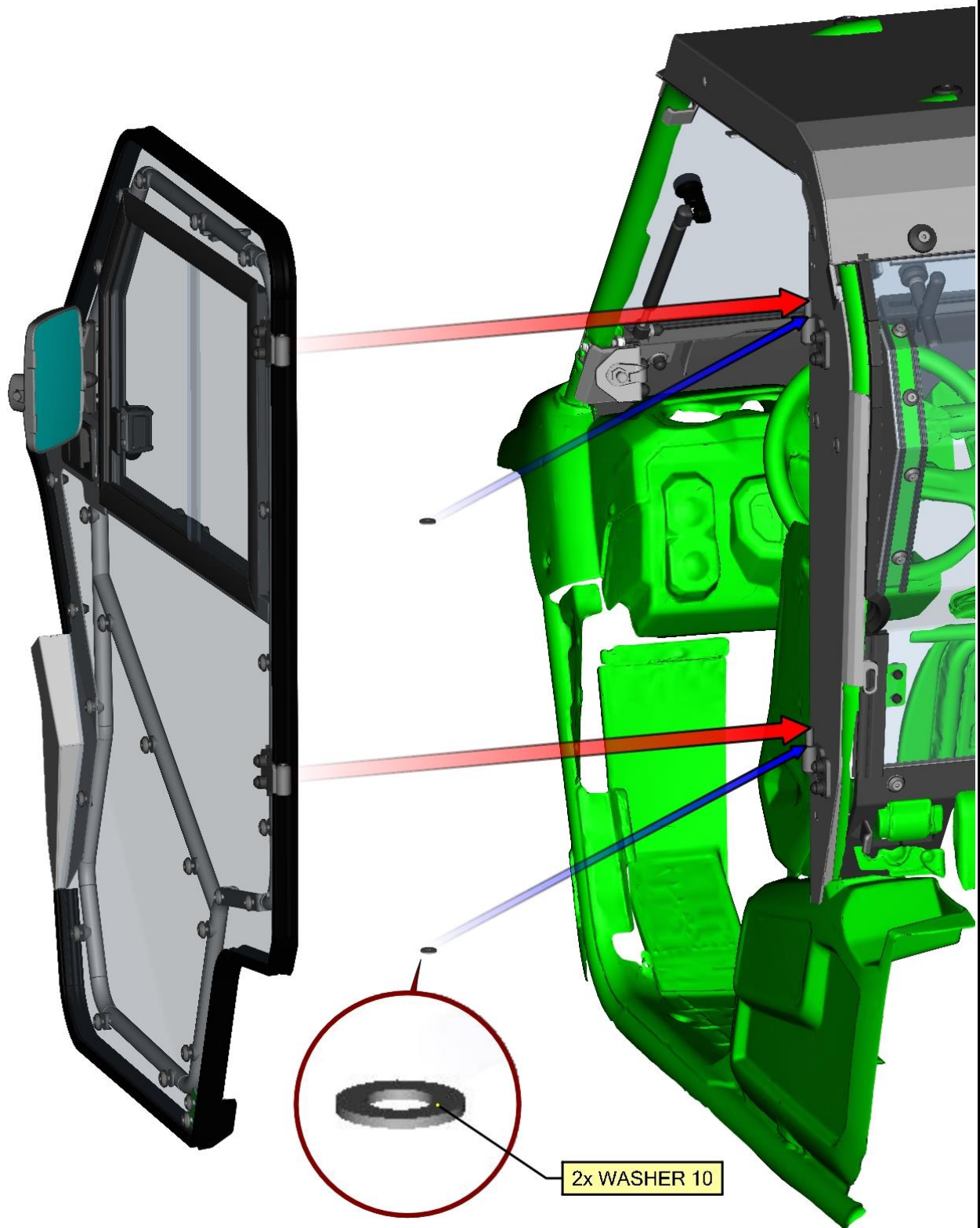

62

If necessary loosen the hinges screws and adjust the door to the best position. After adjustment tighten the hinges screws hard.

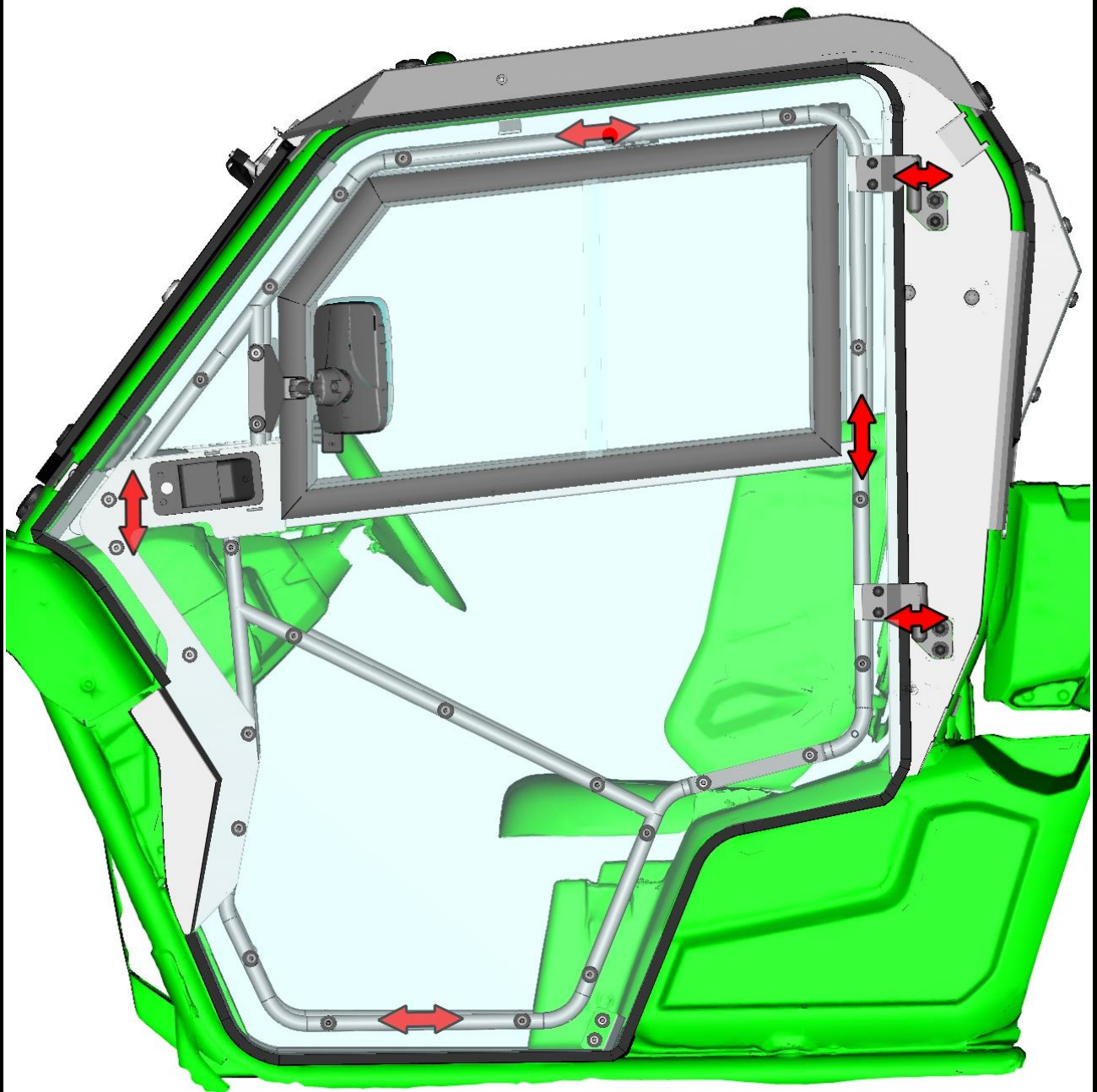

63

Place the left door stop assembly onto the left front bottom ledge holder.

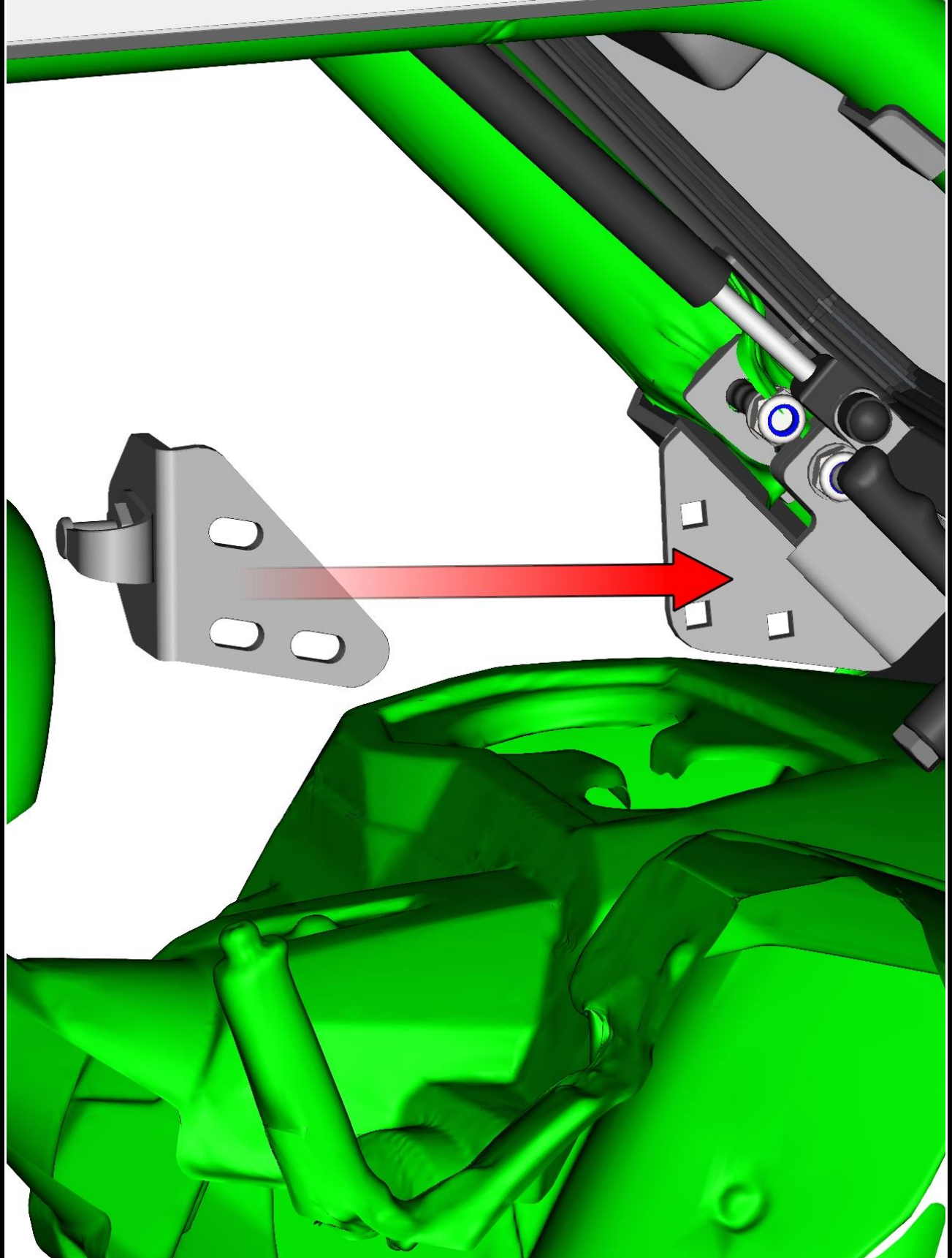

64



Attach the left door stop with included screws, washers, nuts and covers.

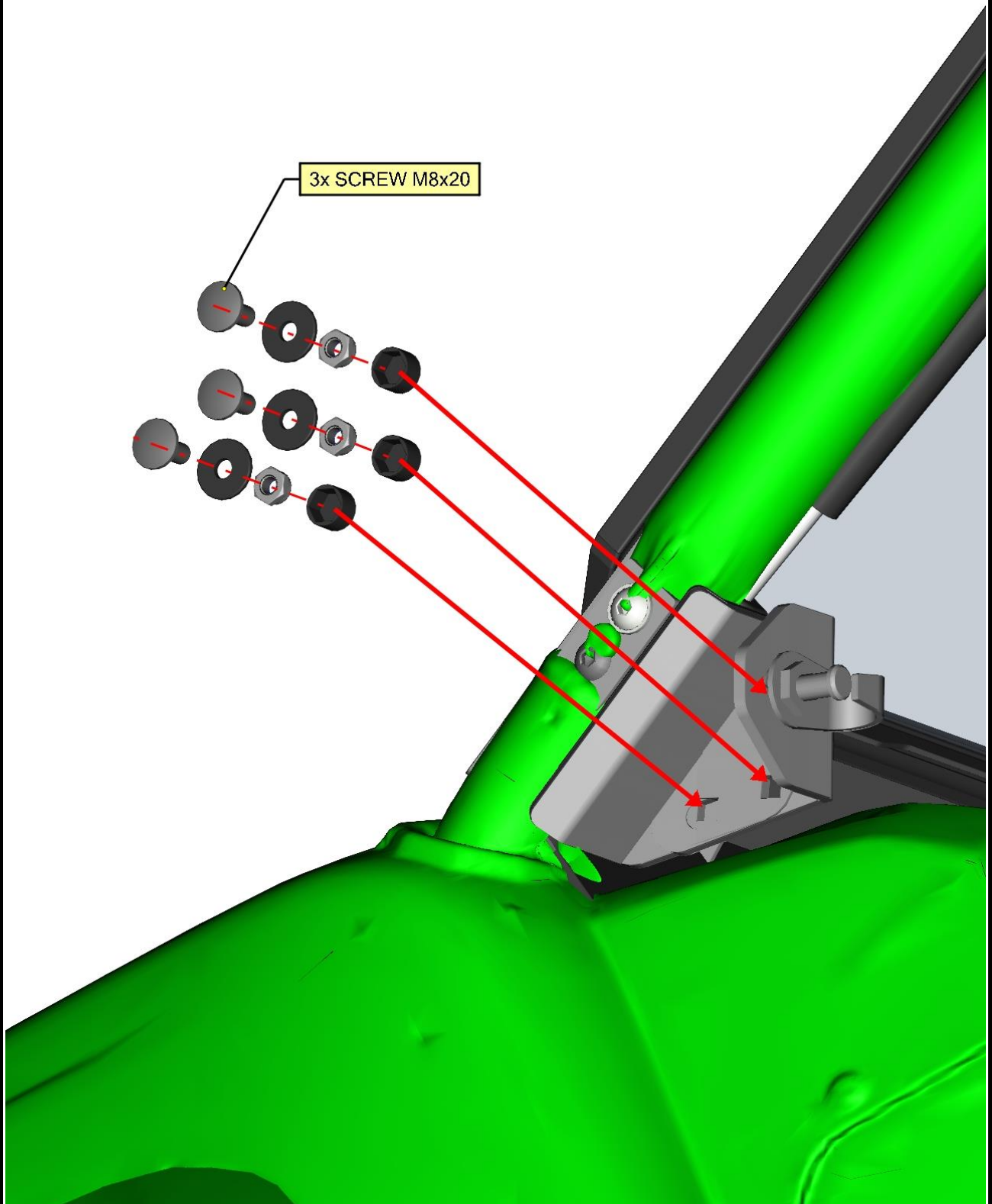

65

Adjust the door stop holder and door stop to the best position with the door. **If you have adjusted the door stop correctly, when you close the door slowly you will hear 2 clear metallic clicks.**

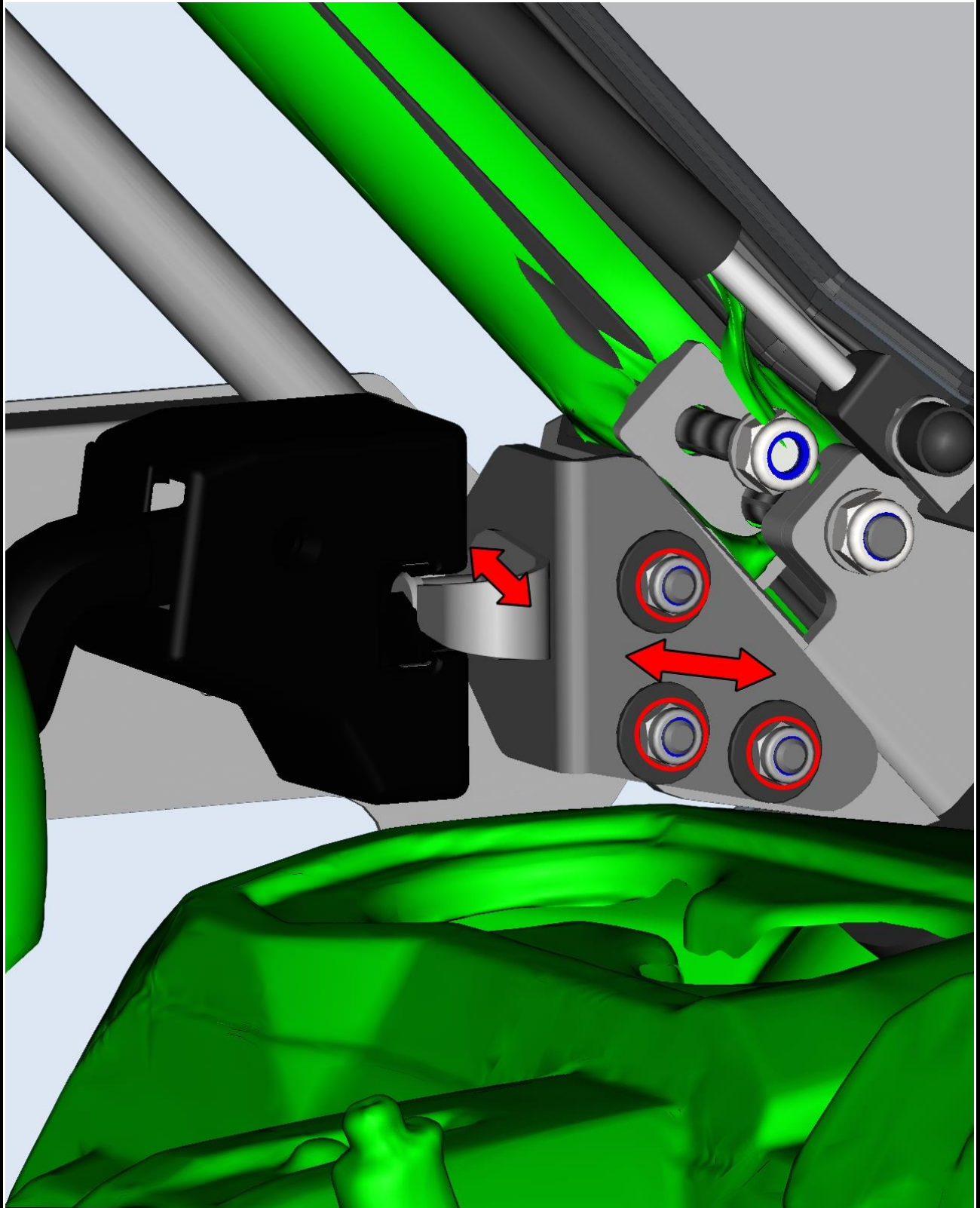

66

Mount the left rear view mirror with included fixing assemblies.

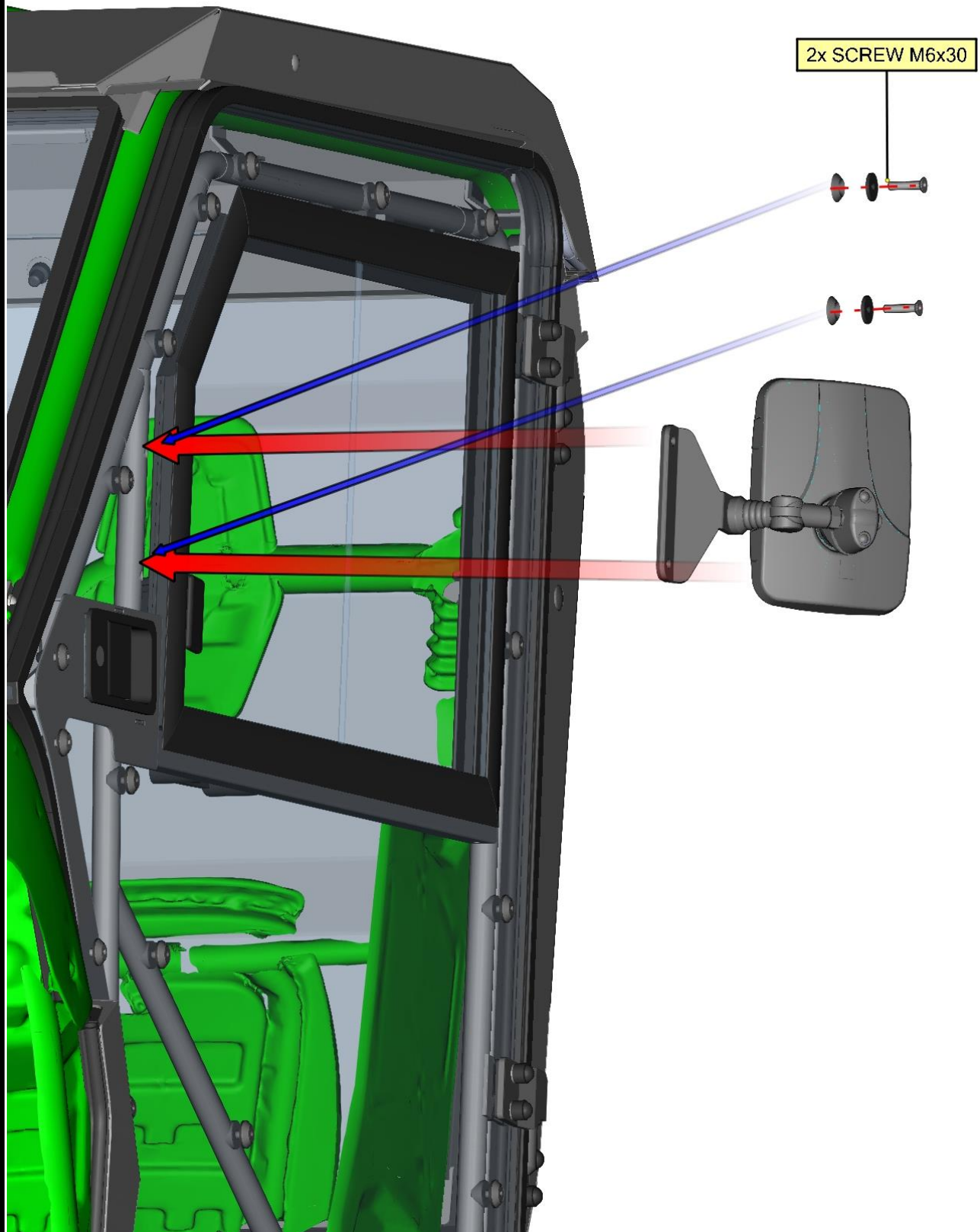

67

Mount the gas spring pins into the gas spring pin holders.

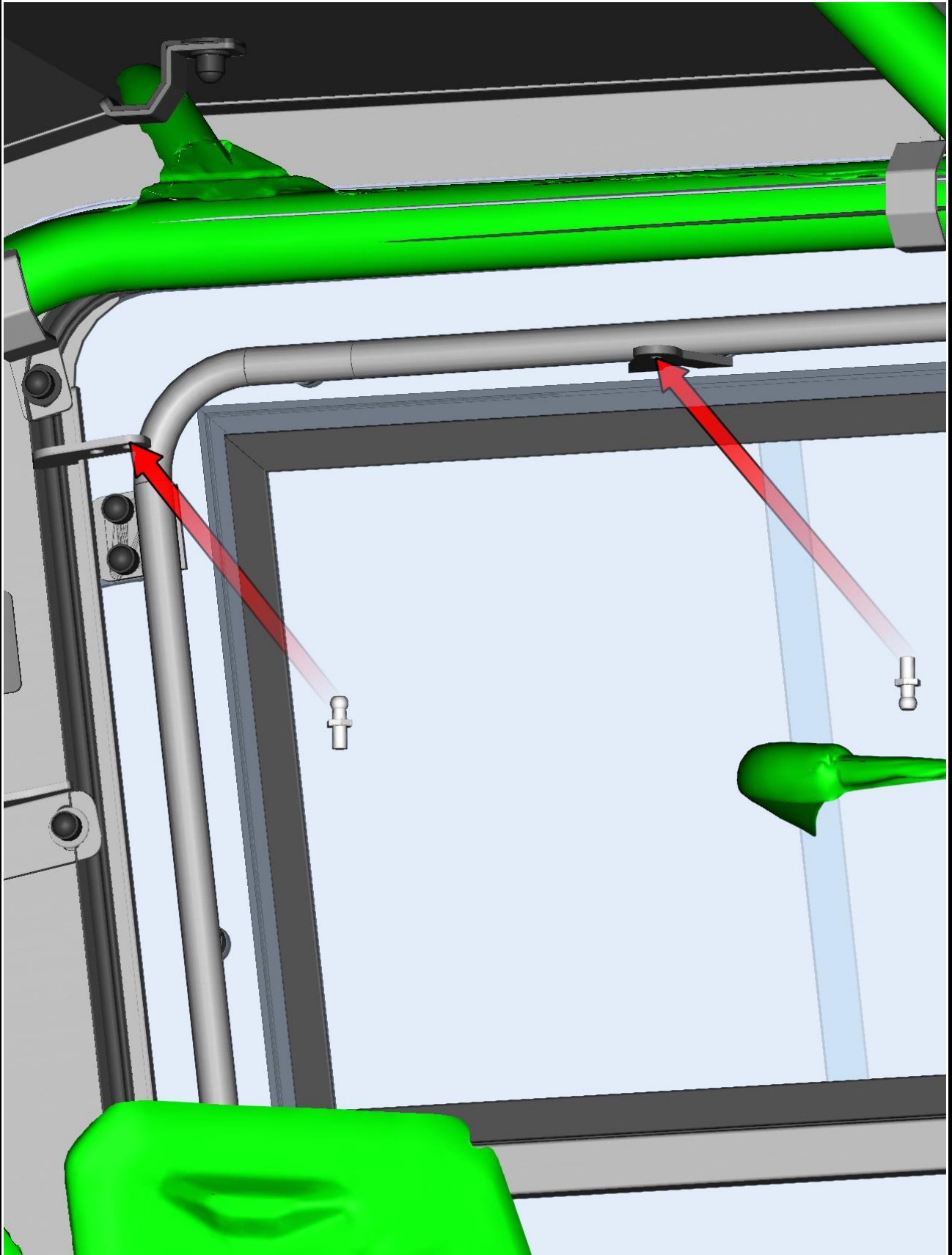

68

Install the door gas spring onto the gas spring pins.

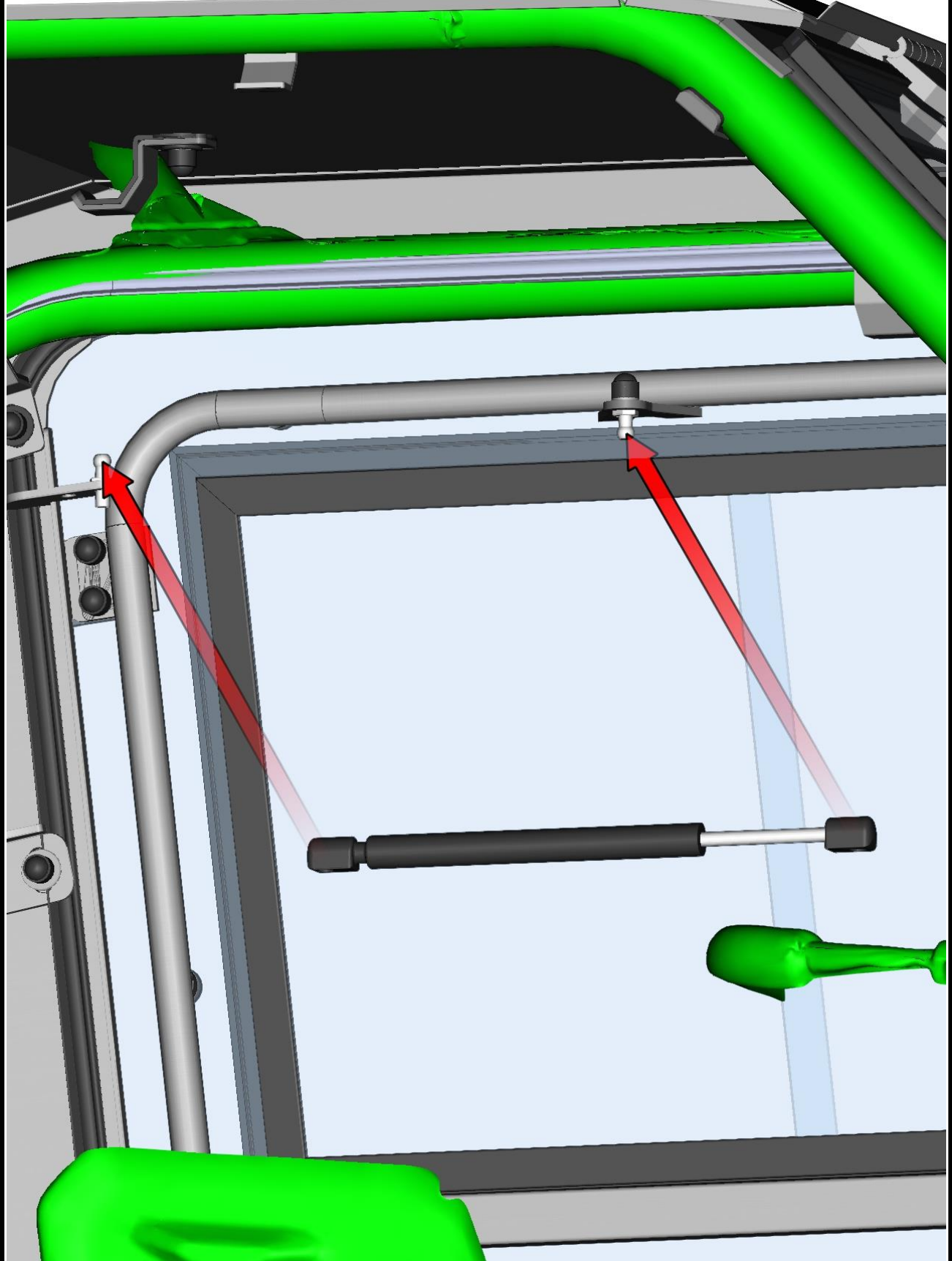

69

Repeat the previous steps with the right door assembly.

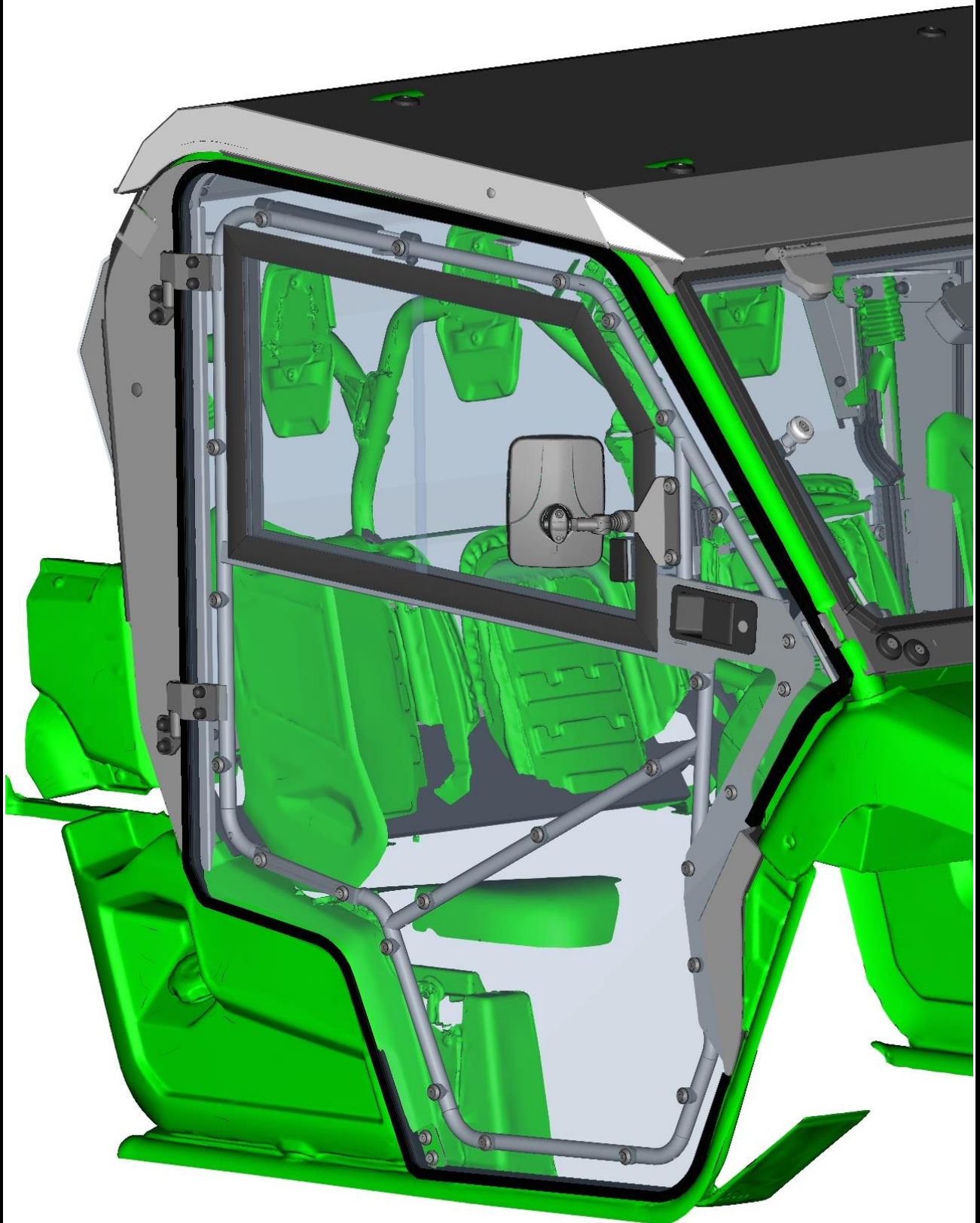

70

# BOLT TORQUE

## BOLT TORQUE SPECIFICATIONS

### GENERAL TORQUE SPECIFICATION TABLE

Use the following torques when special torques are not given. These values apply to fasteners as received from suppliers, dry, or when lubricated with normal engine oil. They do not apply if special graphited or moly disulphide greases or other extreme pressure lubricants are used. This applies to both UNF and UNC threads. Remember to always use grade five or better when replacing bolts.

**IMPORTANT: On all PLATED GRADE 8 bolts, reduce torque 15% from listed bolt torque specification.**

SAE Grade No.		2				5				8*			
Bolt head identification mark as per grade. NOTE: Manufacturing Marks Will Vary													
Bolt Size		TORQUE				TORQUE				TORQUE			
		Pounds Feet		Newton-Meters		Pounds Feet		Newton-Meters		Pounds Feet		Newton-Meters	
Inches	Millimeters	Min.	Max.	Min.	Max.	Min.	Max.	Min.	Max.	Min.	Max.	Min.	Max.
1/4	6.35	5	6	7	8	9	11	12	15	12	15	16	20
5/16	7.94	10	12	14	16	17	20.5	23	28	24	29	33	39
3/8	9.53	20	23	27	31	35	42	48	57	45	54	61	73
7/16	11.11	30	35	41	47	54	64	73	87	70	84	95	114
1/2	12.70	45	52	61	70	80	96	109	130	110	132	149	179
9/16	14.29	65	75	88	102	110	132	149	179	160	192	217	260
5/8	15.88	95	105	129	142	150	180	203	244	220	264	298	358
3/4	19.05	150	185	203	251	270	324	366	439	380	456	515	618
7/8	22.23	160	200	217	271	400	480	542	651	600	720	814	976
1	25.40	250	300	339	406	580	696	787	944	900	1080	1220	1464
1-1/8	25.58	-	-	-	-	800	880	1085	1193	1280	1440	1736	1953
1-1/4	31.75	-	-	-	-	1120	1240	1519	1681	1820	2000	2468	2712
1-3/8	34.93	-	-	-	-	1460	1680	1980	2278	2380	2720	3227	3688
1-1/2	38.10	-	-	-	-	1940	2200	2631	2983	3160	3560	4285	4827

\*Thick Nuts must be used with Grade 8 bolts

### METRIC BOLT TORQUE SPECIFICATIONS

Size of Screw	Property Class	Course Thread			Fine Thread		
		Pitch (mm)	Pounds Feet	Newton-Meters	Pitch (mm)	Pounds Feet	Newton-Meters
M6	5.6	1.0	3.6-5.8	4.9-7.9	-	-	-
	8.8		5.8-9.4	7.9-12.7		-	-
	10.9		7.2-10	9.8-13.6		-	-
M8	5.6	1.25	7.2-14	9.8-19	1.0	12-17	16.3-23
	8.8		17-22	23-29.8		19-27	25.7-36.6
	10.9		20-26	27.1-35.2		22-31	29.8-42
M10	5.6	1.5	20-25	27.1-33.9	1.25	20-29	27.1-39.3
	8.8		34-40	46.1-54.2		35-47	47.4-63.7
	10.9		38-46	51.5-62.3		40-52	54.2-70.5
M12	5.6	1.75	28-34	37.9-46.1	1.25	31-41	42-55.6
	8.8		51-59	69.1-79.9		55-68	75.9-92.1
	10.9		57-66	77.2-89.4		62-75	84-101.6
M14	5.6	2.0	49-56	66.4-75.9	1.5	52-64	70.5-86.7
	8.8		81-93	109.8-126		90-106	122-143.6
	10.9		96-109	130.1-147.7		107-124	145-168
M16	5.6	2.0	67-77	90.8-104.3	1.5	69-83	93.6-112.5
	8.8		116-130	157.2-176.2		120-138	162.6-187
	10.9		129-145	174.8-196.5		140-158	189.7-214.1
M18	5.6	2.0	88-100	119.2-136	1.5	100-117	136-158.5
	8.8		150-168	203.3-227.6		177-199	239.8-269.6
	10.9		175-194	237.1-262.9		202-231	273.7-313
M20	5.6	2.5	108-130	146.3-176.2	1.5	132-150	178.9-203.3
	8.8		186-205	252-277.8		206-242	279.1-327.9
	10.9		213-249	288.6-337.4		246-289	333.3-391.6



## **Declaration of Conformity**



**DFK Cab, s.r.o.**

Za Olšávkou 391

686 01 Uherské Hradiště

Česká republika / Czech Republic

Date of Issue: 31-3-2017